

## Tiny Predictive Fan Failure Detector

### Features

- Fan Wear-Out Detection for 2-Wire Linear-Controlled Fans
- Replacement System for 3-Wire Fans
- Fan Alert Signal when Fan Speed is below Programmed Threshold
- CLEAR Capability for Eliminating False Alarm
- Low Operating Current, 90  $\mu$ A (typ.)
- $V_{DD}$  Range 3.0V to 5.5V
- Available in a 6-Pin SOT-23 Package

### Applications

- Protection for Linear-Controlled Fans
- Power Supplies
- Industrial Equipment
- PCs and Notebooks
- Data Storage
- Data Communications Equipment
- Instrumentation

### Package Type

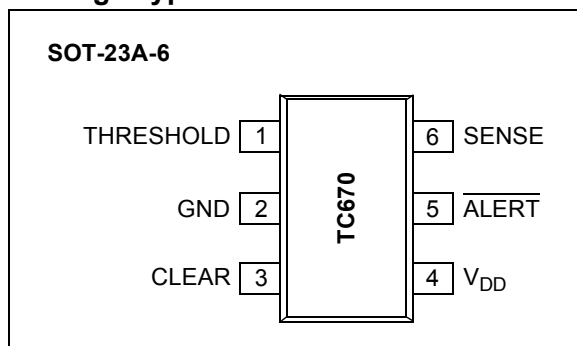

### General Description

The TC670 is an integrated fan speed sensor that predicts and/or detects fan failure, preventing thermal damage to systems with cooling fans. When the fan speed falls below a user-specified level, the TC670 asserts an  $\overline{\text{ALERT}}$  signal. With this design, a critical minimum fan speed is determined by the user. The fan alert level is then set with a resistor divider on the THRESHOLD pin (Pin 1) of the TC670. When the minimum fan speed is reached, the  $\overline{\text{ALERT}}$  pin (Pin 5) changes from a digital high to low. This failure detection works with all linear-controlled 2-wire fans. The TC670 eliminates the need for 3-wire fan solutions.

A CLEAR option can be used to reset the  $\overline{\text{ALERT}}$  signal, allowing the flexibility of connecting the  $\overline{\text{ALERT}}$  output of the TC670 with other ALERT/FAULT interrupts in the system. This feature can be implemented so that false fan fault conditions do not initiate system shutdown.

The TC670 is specified to operate over the full industrial temperature range of  $-40^{\circ}\text{C}$  to  $+85^{\circ}\text{C}$ . The TC670 is offered in a 6-pin SOT-23 pin package and consumes 90  $\mu$ A (typ.) during operation. The space-saving package and low power consumption make this device an ideal choice for systems requiring fan speed monitoring.

### Typical Application Circuit

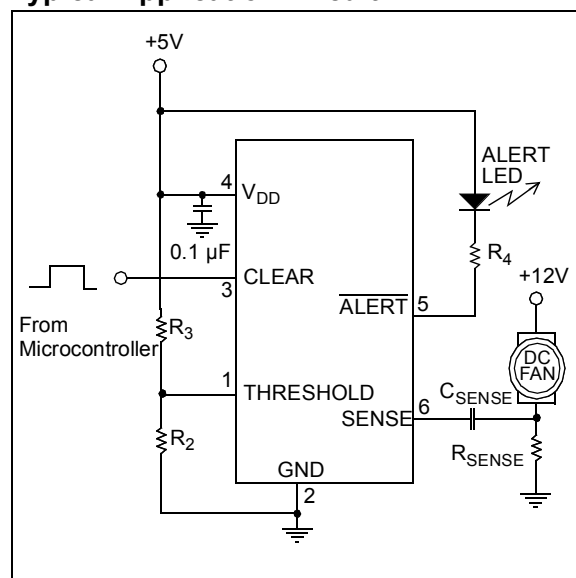

**HY-LINE<sup>®</sup>**  
POWER COMPONENTS

Inselkammerstraße 10      Gründenstrasse 10  
D-82008 Unterhaching      CH-8247 Flurlingen  
Tel.: +49 (0)89 614503 10      Tel.: +41 (0)52 647 42 00  
Fax: +49 (0)89 614503 20      Fax: +41 (0)52 647 42 01  
E-Mail: power@hy-line.de      E-Mail: power@hy-line.ch  
URL: www.hy-line.de      URL: www.hy-line.ch

# TC670

## 1.0 ELECTRICAL CHARACTERISTICS

### Absolute Maximum Ratings†

$V_{DD}$  ..... 6.0V  
 All Inputs and Outputs. .... (GND – 0.3V) to ( $V_{DD}$  + 0.3V)  
 Output Short-Circuit Current ..... continuous  
 Current at Input Pin ..... +/-2 mA  
 Current at Output Pin ..... +/-25 mA  
 Junction Temperature,  $T_J$  ..... 150°C  
 ESD protection on all pins ..... ≥ 4 kV  
 Operating Temperature Range ..... -40°C to +85°C  
 Storage Temperature Range ..... -55°C to +150°C

† **Notice:** Stresses above those listed under "Maximum Ratings" may cause permanent damage to the device. This is a stress rating only and functional operation of the device at those or any other conditions above those indicated in the operation listings of this specification is not implied. Exposure to maximum rating conditions for extended periods may affect device reliability.

TABLE 1-1: PIN FUNCTION TABLE

Symbol	Description
THRESHOLD	Analog Input
GND	Ground Terminal
CLEAR	Digital Input
$V_{DD}$	Bias Supply Input
$\overline{\text{ALERT}}$	Digital (Open-Drain) Output
SENSE	Analog Input

## DC CHARACTERISTICS

**Electrical Specifications:** Unless otherwise specified, all limits are specified at +25°C,  $V_{DD}$  = 3.0V to 5.5V, CLEAR = Low. **Boldface** type specifications apply for temperature range of -40°C to +85°C.

Parameters	Sym	Min	Typ	Max	Units	Conditions
<b>Power Supply</b>						
Supply Voltage	$V_{DD}$	<b>3.0</b>	—	<b>5.5</b>	V	
Supply Current	$I_{DD}$	—	90	<b>150</b>	μA	
<b>CLEAR Input</b>						
Logic Input High Level	$V_{IH}$	<b>0.8</b> $V_{DD}$	—	—	V	
Logic Input Low Level	$V_{IL}$	—	—	<b>0.2</b> $V_{DD}$	V	
<b>SENSE Input</b>						
Input Level Threshold Voltage	$V_{TH(SENSE)}$	—	124	—	mV	
Input Resistance	$R_{SENSE}$	—	50	—	kΩ	
<b>THRESHOLD Input</b>						
Input Voltage Minimum		—	0.0	—	V	
Input Voltage Maximum		—	2.4	—	V	
Input Resistance		—	100	—	MΩ	
Programmed Fan Speed Alert Accuracy (Note 1)	$\overline{\text{ALERT}}_{ACC}$	-10	—	+10	%	$V_{DD} = 3.0V$
<b>ALERT Output</b>						
Output Low Voltage	$V_{LOW}$	—	—	<b>0.3</b>	V	$I_{SINK} = 2.5 \text{ mA}$
Output Delay Time	$t_{DELAY}$	—	176	—	ms	
<b>Temperature Ranges</b>						
Specified Temperature Range	$T_A$	-40	—	+85	°C	
Operating Temperature Range	$T_A$	-40	—	+125	°C	
<b>Thermal Package Resistances</b>						
Thermal Resistance, 6L-SOT-23	$\theta_{JA}$	—	230	—	°C/W	

**Note 1:** The TC670 will operate properly over the entire power supply range of 3.0V to 5.5V. As  $V_{DD}$  varies from 3.0V, accuracy will degrade based on the percentage of  $V_{DD}$ , as shown in Section 2.0, "Typical Performance Curves".

## 2.0 TYPICAL PERFORMANCE CURVES

**Note:** The graphs and tables provided following this note are a statistical summary based on a limited number of samples and are provided for informational purposes only. The performance characteristics listed herein are not tested or guaranteed. In some graphs or tables, the data presented may be outside the specified operating range (e.g., outside specified power supply range) and therefore outside the warranted range.

**Note:** Unless otherwise indicated, all limits are specified at +25°C,  $V_{DD} = 3.0V$  to 5.5V, CLEAR = Low.

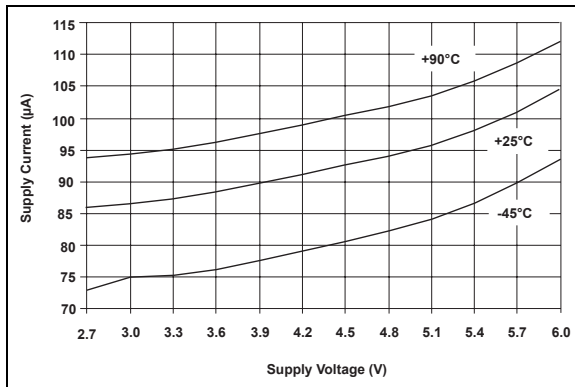

**FIGURE 2-1:** Supply Current vs. Supply Voltage.

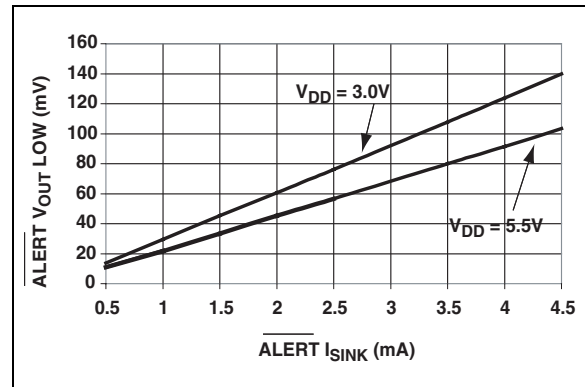

**FIGURE 2-4:**  $\overline{ALERT} V_{LOW}$  vs.  $\overline{ALERT} I_{SINK}$ .

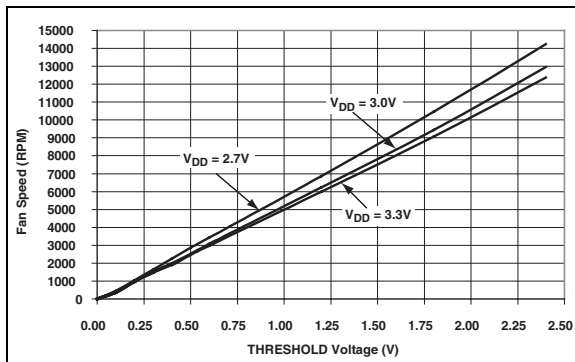

**FIGURE 2-2:** Fan Speed vs. Threshold Voltage.

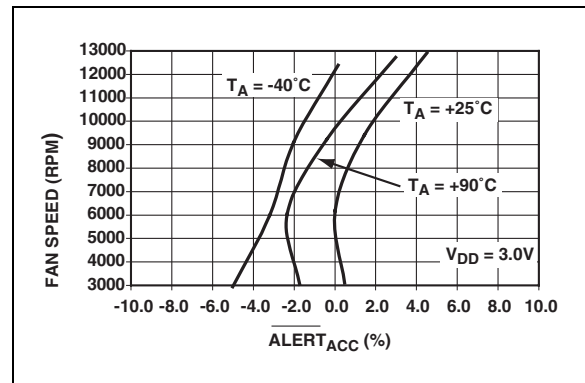

**FIGURE 2-5:** Fan Speed vs.  $\overline{ALERT} ACC$ .

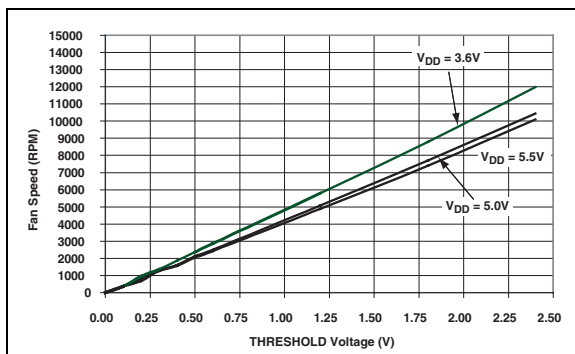

**FIGURE 2-3:** Fan Speed vs. Threshold Voltage.

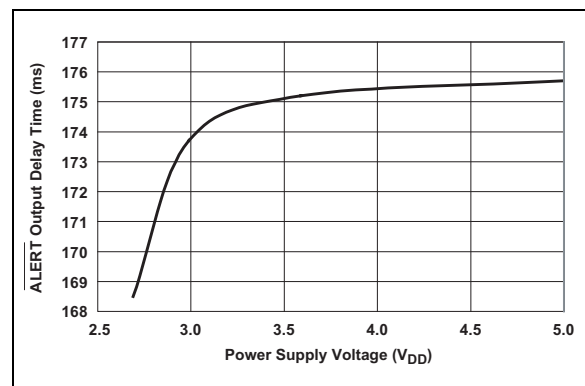

**FIGURE 2-6:**  $\overline{ALERT}$  Output Delay vs. Power Supply Voltage.

# TC670

**Note:** Unless otherwise indicated, all limits are specified at +25°C,  $V_{DD} = 3.0V$  to  $5.5V$ , CLEAR = Low.

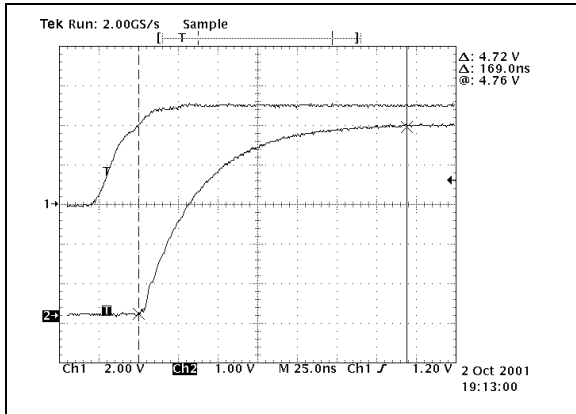

**FIGURE 2-7:** CLEAR pin high to ALERT pin high Timing Diagram.

## 3.0 PIN DESCRIPTIONS

The descriptions of the pins are listed in Table 3-1.

**TABLE 3-1: PIN FUNCTION TABLE**

Pin No.	Symbol	Description
1	THRESHOLD	Analog Input
2	GND	Ground Terminal
3	CLEAR	Digital Input
4	VDD	Bias Supply Input
5	$\overline{\text{ALERT}}$	Digital (Open-Drain) Output
6	SENSE	Analog Input

### 3.1 Analog Input (THRESHOLD)

The voltage set at the THRESHOLD input represents the fan speed at which the TC670 will signal a fan speed warning by pulling the  $\overline{\text{ALERT}}$  output low. The threshold voltage to fan speed correlation can be seen in Figures 2-2 and 2-3.

### 3.2 Ground (GND)

The GND pin (Pin 2) of the TC670 should be connected directly to the analog ground plane of the circuit board. Care should be taken to keep this pin away from switching signals, such as the fan excitation signals in order to avoid false signals on the SENSE pin.

### 3.3 Digital Input (CLEAR)

The CLEAR input is used to reset or blank the  $\overline{\text{ALERT}}$  output. When the CLEAR input is driven high, the  $\overline{\text{ALERT}}$  output will be high-impedance (the  $\overline{\text{ALERT}}$  output requires a pull-up resistor).

### 3.4 Bias Supply Input (V<sub>DD</sub>)

Bias Supply Input, 3.0V to 5.5V. The bias supply input should be bypassed to ground with a 0.1  $\mu\text{F}$  ceramic capacitor.

### 3.5 Digital (Open-Drain) Output ( $\overline{\text{ALERT}}$ )

The  $\overline{\text{ALERT}}$  output is an open-drain output that requires an external pull-up resistor. The  $\overline{\text{ALERT}}$  output is pulled low when the sensed fan speed (detected by the pulses occurring at the SENSE input) falls below the speed that is represented by the voltage at the THRESHOLD pin. The  $\overline{\text{ALERT}}$  output is latched in this state until power is cycled or the CLEAR input is toggled.

### 3.6 Analog Input (SENSE)

Voltage pulses, which are generated by the fan current flowing through a sense resistor, are detected at the SENSE pin and used to calculate the fan speed.

## 4.0 DETAILED DESCRIPTION

The TC670 is an integrated fan speed sensor that predicts/detects fan failure, consequently preventing thermal damage to systems with cooling fans. When the fan speed falls below a user-programmed threshold level, the TC670 asserts an  $\overline{\text{ALERT}}$  signal. This threshold is set with an external resistor divider network.

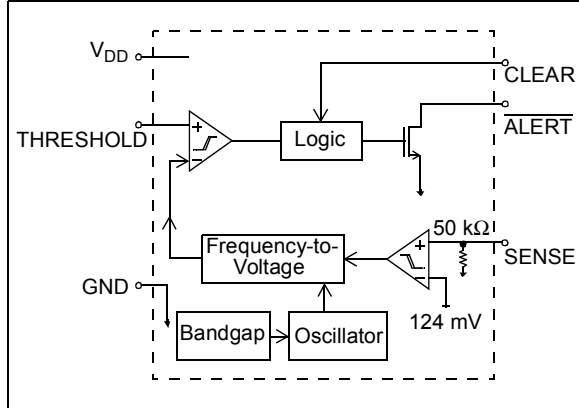
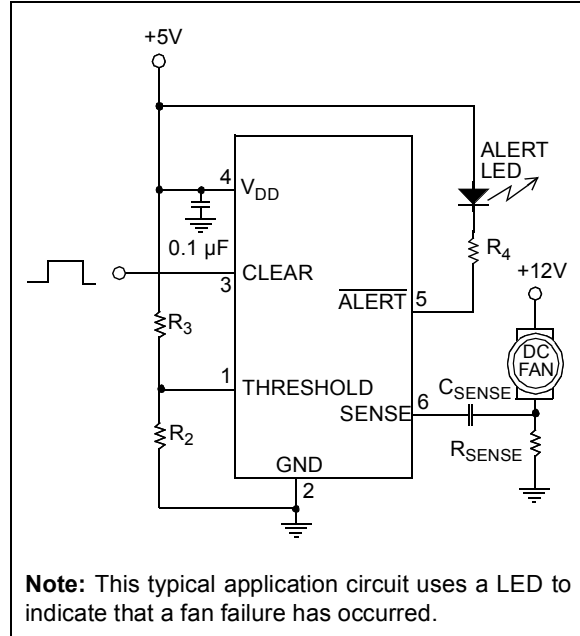

**FIGURE 4-1:** TC670 Block Diagram.

As shown in Figure 4-1, the TC670 senses the fan pulses and internally converts those pulses from a frequency into an analog voltage. This voltage is then compared with the DC voltage at the THRESHOLD pin. If the converted frequency-to-voltage value from the fan's pulses falls below the threshold voltage, the  $\overline{\text{ALERT}}$  output is pulled low.

In a 3.0V system, the external fan alert level on the THRESHOLD pin can be designed from 0.0V (stalled fan) to 2.4V (for 13,000 RPM) to cover most of the common fan speeds. This failure detection system works with linear-controlled 2-wire fans and eliminates the need for 3-wire fans. The TC670 can also work with 3-wire fans either by using the SENSE circuit or by directly sensing the RPM output from the 3rd wire.

A CLEAR pin is provided to allow the user to reset the ALERT pin status back to a high state. This clear option also allows the flexibility of connecting the ALERT output of the TC670 with other alert/fault interrupts in the system without having a risk of a system shutdown due to false fan fault condition.



**Note:** This typical application circuit uses a LED to indicate that a fan failure has occurred.

**FIGURE 4-2:** Typical Application Circuit.

### 4.1 SENSE Input

As shown in Figure 4-2, the SENSE input (Pin 6) is connected to the sense resistor ( $R_{\text{SENSE}}$ ) through a capacitor ( $C_{\text{SENSE}}$ ). The low value current sensing resistor ( $R_{\text{SENSE}}$ ) is connected between the ground return leg of the fan and the fan bias ground. During normal fan operation, commutation occurs as each pole of the fan is energized. This causes the fan current to be an AC waveform with fast falling edges.

These short, rapid changes in fan current cause a corresponding  $dV/dt$  voltage across the sense resistor, as well as a corresponding  $dI/dt$  current through the sense capacitor. The current through  $C_{\text{SENSE}}$  is terminated with the internal 50 kΩ input resistance at the SENSE pin of the TC670. When positive-going fan pulses at the SENSE input are greater than 124 mV (typ.), the TC670 latches-in those voltage spikes. This 124 mV (typ.) SENSE input built-in threshold reduces false triggering errors caused by extraneous noise pulses associated with a running fan. The presence and frequency of these pulses is a direct indication of fan operation and fan speed.

The design of the proper input SENSE circuitry is a matter of scaling  $R_{SENSE}$  to provide the necessary amount of gain and proper selection of the sensing capacitor. The following table (Table 4-1) lists some recommended values for  $R_{SENSE}$  according to the nominal operating current of the fan. Please note that the current draw specified by the fan manufacturer may be a worst-case rating and not the fan's nominal operating current. If the fan current falls between two of the values listed, it is recommended that the higher value resistor is used.

**TABLE 4-1: RECOMMENDED VALUES FOR  $R_{SENSE}$  PER FIGURE 4-2**

Nominal Fan Current (mA)	$R_{SENSE}$ ( $\Omega$ )
100	4.7
200	2.4
300	1.8
400	1.3
500	1.0
600	0.8

A 0.1  $\mu$ F ceramic capacitor is recommended for  $C_{SENSE}$ . Smaller capacitor values will require larger sense resistors, whereas larger capacitors are more expensive and occupy more board space.

## 4.2 THRESHOLD Input

The voltage at the THRESHOLD input sets the equivalent minimum allowable fan speed for the application. As shown in Section 2.0, "Typical Performance Curves", the relationship between the threshold voltage and minimum fan speed is also power supply and temperature dependant.

All the values for the threshold voltage that are shown in these graphs represent typical numbers and might not be optimized for all fans in all applications. To ensure accurate fan speed monitoring of a specific fan in a specific application, the user must perform a one-time correlation check with the prototype.

There are two techniques that can be used to calibrate the system. One approach is to find the fan's full-scale capability and mathematically estimate the minimum acceptable speed of the fan. A second technique is to identify the fan's minimum speed and calibrate the threshold voltage accordingly.

### 4.2.1 THRESHOLD CALIBRATION USING FAN'S FULL SCALE SPEED

The fan should first be run at full speed. At full speed, the threshold voltage level should be adjusted until the  $\overline{ALERT}$  output is asserted. With this full-scale value of the threshold voltage, the value can be scaled down to the fan fault speed as a percentage of the full speed. For example, if the fan full speed threshold voltage is 1.5V, then the fan fault threshold voltage at 30% of full speed would be  $30\% \times 1.5V = 0.45V$ .

### 4.2.2 THRESHOLD CALIBRATION USING FAN'S MINIMUM ALLOWABLE SPEED ESTIMATE

For a more exact fan fault trip point, the user can run the fan at its minimum allowed speed. At this speed, the threshold voltage can be adjusted until the  $\overline{ALERT}$  output is asserted.

## 4.3 CLEAR Input

The CLEAR input allows the user to reset the  $\overline{ALERT}$  pin to a high status. This is an active-high input. Consequently, as long as CLEAR is high,  $\overline{ALERT}$  will always be high as well. To allow  $\overline{ALERT}$  to operate correctly, CLEAR must be held low. This feature can be implemented so that false fan fault conditions do not initiate system shutdown.

## 4.4 ALERT Output

The  $\overline{ALERT}$  output is an open-drain output capable of sinking 2.5 mA (typ). The  $\overline{ALERT}$  output is asserted whenever the detected fan speed equals or falls below the equivalent voltage set at the threshold pin. The  $\overline{ALERT}$  output is only deactivated once the CLEAR pin is brought to a high state. Although the absolute maximum sink current of this pin is 25 mA, it is recommended that the current sinking into the  $\overline{ALERT}$  output does not exceed 20 mA.

## 4.5 Power Supply Input ( $V_{DD}$ )

To assure proper operation of the TC670 in a noisy environment where the fans are running, the  $V_{DD}$  pin (Pin 4) must be decoupled with a 0.1  $\mu$ F capacitor, as shown in Figure 4-1. This capacitor should be located as close to the TC670  $V_{DD}$  pin as possible, as well as being promptly terminated to the ground plane. A ceramic capacitor is recommended.

## 4.6 Ground Terminal (GND)

The GND pin (Pin 2) of the TC670 should be connected directly to the analog ground plane of the circuit board. Care should be taken to keep this pin away from switching signals, such as the fan excitation signals in order to avoid false signals on the SENSE pin.

# TC670

## 5.0 PACKAGE INFORMATION

### 5.1 Package Marking Information

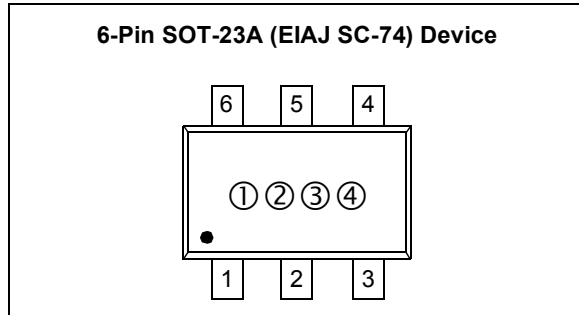

1 & 2 = part number code

Part Number	Code
TC670ECH	DA

3 = year and quarter code

4 = lot ID number

### 5.2 Taping Form

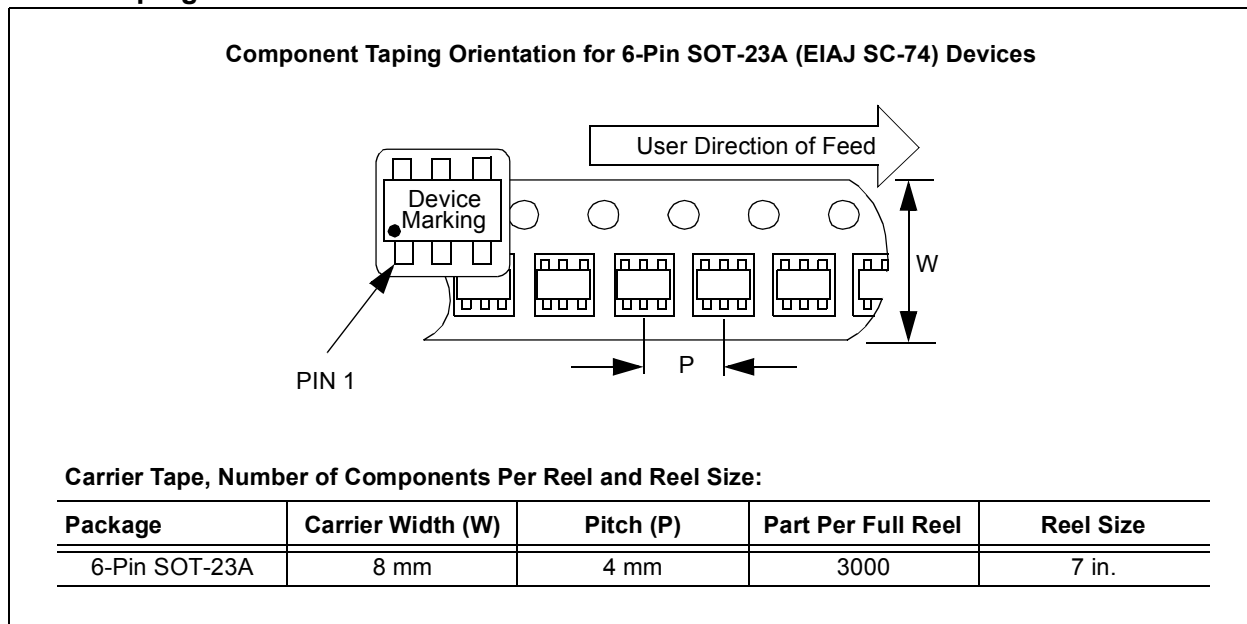



## 5.3 Package Dimensions (6-Pin SOT-23)

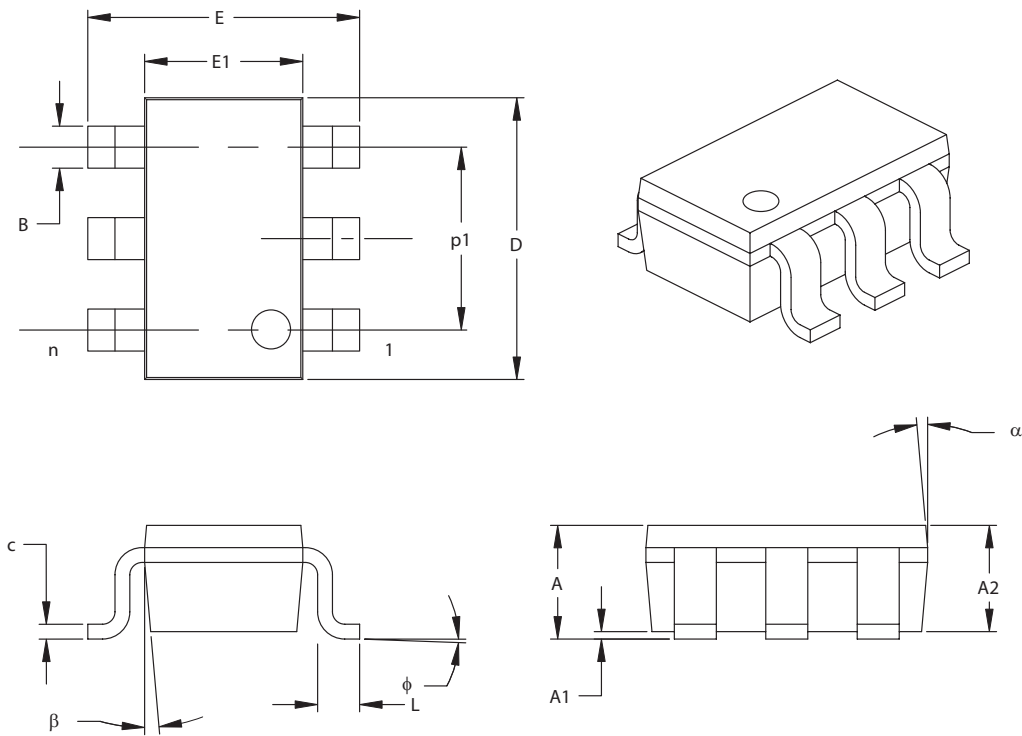

Dimension Limits	Units	INCHES*			MILLIMETERS		
		MIN	NOM	MAX	MIN	NOM	MAX
Number of Pins	n		6			6	
Pitch	P		.038			0.95	
Outside lead pitch (basic)	p1		.075			1.90	
Overall Height	A	.035	.046	.057	0.90	1.18	1.45
Molded Package Thickness	A2	.035	.043	.051	0.90	1.10	1.30
Standoff	A1	.000	.003	.006	0.00	0.08	0.15
Overall Width	E	.102	.110	.118	2.60	2.80	3.00
Molded Package Width	E1	.059	.064	.069	1.50	1.63	1.75
Overall Length	D	.110	.116	.122	2.80	2.95	3.10
Foot Length	L	.014	.018	.022	0.35	0.45	0.55
Foot Angle	$\phi$	0	5	10	0	5	10
Lead Thickness	c	.004	.006	.008	0.09	0.15	0.20
Lead Width	B	.014	.017	.020	0.35	0.43	0.50
Mold Draft Angle Top	$\alpha$	0	5	10	0	5	10
Mold Draft Angle Bottom	$\beta$	0	5	10	0	5	10

\*Controlling Parameter

Notes:

Dimensions D and E1 do not include mold flash or protrusions. Mold flash or protrusions shall not exceed .005" (0.127mm) per side.

JEITA (formerly EIAJ) equivalent: SC-74A

Drawing No. C04-120

# TC670

---

---

NOTES:

## PRODUCT IDENTIFICATION SYSTEM

To order or obtain information, e.g., on pricing or delivery, refer to the factory or the listed sales office.

<u>PART NO.</u>	<u>X</u>	<u>XXXX</u>
Device	Temperature Range	Package
Device:	TC670:	Predictive Fan Failure Detector
Temperature Range:	E =	-40°C to +85°C
Package:	CHTR: =	SOT-23, Small Outline Transistor, 6-lead (Tape and Reel only)

**Examples:**

a) TC670ECHTR: Predictive Fan Failure Detector, SOT-23 package.

## Sales and Support

### Data Sheets

Products supported by a preliminary Data Sheet may have an errata sheet describing minor operational differences and recommended workarounds. To determine if an errata sheet exists for a particular device, please contact one of the following:

1. Your local Microchip sales office
2. The Microchip Corporate Literature Center U.S. FAX: (480) 792-7277
3. The Microchip Worldwide Site ([www.microchip.com](http://www.microchip.com))

Please specify which device, revision of silicon and Data Sheet (include Literature #) you are using.

### Customer Notification System

Register on our web site ([www.microchip.com/cn](http://www.microchip.com/cn)) to receive the most current information on our products.

# TC670

---

NOTES:

---

**Note the following details of the code protection feature on Microchip devices:**

- Microchip products meet the specification contained in their particular Microchip Data Sheet.
- Microchip believes that its family of products is one of the most secure families of its kind on the market today, when used in the intended manner and under normal conditions.
- There are dishonest and possibly illegal methods used to breach the code protection feature. All of these methods, to our knowledge, require using the Microchip products in a manner outside the operating specifications contained in Microchip's Data Sheets. Most likely, the person doing so is engaged in theft of intellectual property.
- Microchip is willing to work with the customer who is concerned about the integrity of their code.
- Neither Microchip nor any other semiconductor manufacturer can guarantee the security of their code. Code protection does not mean that we are guaranteeing the product as "unbreakable."

Code protection is constantly evolving. We at Microchip are committed to continuously improving the code protection features of our products. Attempts to break microchip's code protection feature may be a violation of the Digital Millennium Copyright Act. If such acts allow unauthorized access to your software or other copyrighted work, you may have a right to sue for relief under that Act.

---

Information contained in this publication regarding device applications and the like is intended through suggestion only and may be superseded by updates. It is your responsibility to ensure that your application meets with your specifications. No representation or warranty is given and no liability is assumed by Microchip Technology Incorporated with respect to the accuracy or use of such information, or infringement of patents or other intellectual property rights arising from such use or otherwise. Use of Microchip's products as critical components in life support systems is not authorized except with express written approval by Microchip. No licenses are conveyed, implicitly or otherwise, under any intellectual property rights.

**HY-LINE®**

**POWER COMPONENTS**

Inselkammerstraße 10	Gründenstrasse 10
D-82008 Unterhaching	CH-8247 Flurlingen
Tel.: +49 (0)89 614503 10	Tel.: +41 (0)52 647 42 00
Fax: +49 (0)89 614503 20	Fax: +41 (0)52 647 42 01
E-Mail: power@hy-line.de	E-Mail: power@hy-line.ch
URL: www.hy-line.de	URL: www.hy-line.ch

**Trademarks**

The Microchip name and logo, the Microchip logo, KEELoQ, MPLAB, PIC, PICmicro, PICSTART, PRO MATE and PowerSmart are registered trademarks of Microchip Technology Incorporated in the U.S.A. and other countries.

FilterLab, microID, MXDEV, MXLAB, PICMASTER, SEEVAL and The Embedded Control Solutions Company are registered trademarks of Microchip Technology Incorporated in the U.S.A.

Accuron, Application Maestro, dsPIC, dsPICDEM, dsPICDEM.net, ECONOMONITOR, FanSense, FlexROM, fuzzyLAB, In-Circuit Serial Programming, ICSP, ICEPIC, microPort, Migratable Memory, MPASM, MPLIB, MPLINK, MPSIM, PICC, PICkit, PICDEM, PICDEM.net, PowerCal, PowerInfo, PowerMate, PowerTool, rLAB, rPIC, Select Mode, SmartSensor, SmartShunt, SmartTel and Total Endurance are trademarks of Microchip Technology Incorporated in the U.S.A. and other countries.

Serialized Quick Turn Programming (SQTP) is a service mark of Microchip Technology Incorporated in the U.S.A.

All other trademarks mentioned herein are property of their respective companies.

© 2003, Microchip Technology Incorporated, Printed in the U.S.A., All Rights Reserved.

 Printed on recycled paper.

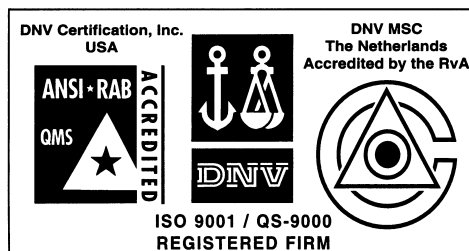

Microchip received QS-9000 quality system certification for its worldwide headquarters, design and wafer fabrication facilities in Chandler and Tempe, Arizona in July 1999 and Mountain View, California in March 2002. The Company's quality system processes and procedures are QS-9000 compliant for its PICmicro® 8-bit MCUs, KEELoQ® code hopping devices, Serial EEPROMs, microperipherals, non-volatile memory and analog products. In addition, Microchip's quality system for the design and manufacture of development systems is ISO 9001 certified.



**MICROCHIP**

---

---

## **Kontaktinformationen**

---

---

**Ihr Vertriebspartner:**  
**HY-LINE<sup>®</sup>**  
**POWER COMPONENTS**

Inselkammerstraße 10	Gründenstrasse 10
D-82008 Unterhaching	CH-8247 Flurlingen
Tel.: +49 (0)89 614503 10	Tel.: +41 (0)52 647 42 00
Fax: +49 (0)89 614503 20	Fax: +41 (0)52 647 42 01
E-Mail: <a href="mailto:power@hy-line.de">power@hy-line.de</a>	E-Mail: <a href="mailto:power@hy-line.ch">power@hy-line.ch</a>
URL: <a href="http://www.hy-line.de">www.hy-line.de</a>	URL: <a href="http://www.hy-line.ch">www.hy-line.ch</a>