

# UD info Corp.

Industrial M.2 2260 SATA Drive

M2S-60UD Series

Product DataSheet

**UD info CORP.**

3F-4, No.8, Ln. 609, Sec. 5, Chongxin Rd., Sanchong Dist., New Taipei City 241, Taiwan (R.O.C.)

TEL: +886-2-7713-6050 FAX: +886-2-8511-3151

E-mail: [sales@UDinfo.com.tw](mailto:sales@UDinfo.com.tw)

<b>1.</b>	<b>Introduction .....</b>	<b>5</b>
1.1.	General Description .....	5
1.2.	Block Diagram .....	5
<b>2.</b>	<b>Product Specifications.....</b>	<b>6</b>
<b>3.</b>	<b>Environmental Specifications .....</b>	<b>9</b>
3.1.	Environmental Conditions .....	9
3.1.1.	Temperature and Humidity .....	9
3.1.2.	Shock.....	10
3.1.3.	Vibration.....	10
3.1.4.	Drop .....	10
3.1.5.	Bending .....	10
3.1.6.	Torque .....	11
3.1.7.	Electrostatic Discharge (ESD) .....	11
3.2.	MTBF.....	11
3.3.	Certification .....	11
3.4.	Compliance .....	11
<b>4.</b>	<b>Electrical Specifications .....</b>	<b>12</b>
4.1.	Supply Voltage.....	12
4.2.	Power Consumption.....	12
<b>5.</b>	<b>Interface.....</b>	<b>14</b>
5.1.	Pin Assignment and Descriptions .....	14
<b>6.</b>	<b>Supported Commands.....</b>	<b>17</b>
6.1.	ATA Command List.....	17
6.2.	Identify Device Data .....	18
<b>7.</b>	<b>Physical Dimension .....</b>	<b>23</b>
<b>8.</b>	<b>Terminology .....</b>	<b>24</b>
<b>9.</b>	<b>Barcode description .....</b>	<b>24</b>
<b>10.</b>	<b>Partnumber decoder .....</b>	<b>25</b>

## Revision History

Revision	Draft Date	History	Author
1.0	2014/6/9	New release	Golden Lee
1.1	2014/11/11	Modify Partnumber decoder	Golden Lee
1.2	2015/6/18	Update highest capacity for MLC & pSLC	Golden Lee
1.3	2016/4/22	Add capacity information & performance & power consumption for each capacity	Golden Lee
1.4	2017/1/3	Add 16GB Flash combination for 32GB capacity	Golden Lee



## Product Overview

- **Capacity**
  - SLC: 1GB up to 64GB
  - MLC: 4GB up to 256GB
  - pSLC: 2GB up to 128GB
- **SATA Interface**
  - SATA Revision 3.0
  - SATA 1.5Gbps, 3Gbps, and 6Gbps interface
- **Flash Interface**
  - Flash Type: SLC,MLC and pSLC
- **Performance**
  - Read: up to 500 MB/s
  - Write: up to 180 MB/s
- **Power Consumption<sup>Note1</sup>**
  - Active mode: < 1650mW
  - Idle mode: < 325mW
  - DEVSLP mode: < 5mW
- **TBW (Terabyte Written)**
  - SLC: 3,448 TBW for 64GB
  - MLC: 635 TBW for 256GB
  - pSLC: 3176 TBW for 128GB
- **MTBF**
  - SLC: 3,000,000 hours
  - MLC: 2,000,000 hours
  - pSLC: 2,500,000 hours
- **Advanced Flash Management**
  - Static and Dynamic Wear Leveling
  - Bad Block Management
  - TRIM
  - SMART
  - Over-Provision
- **Low Power Management**
  - DEVSLP Mode (Optional)
  - DIPM/HIPM Mode
- **Temperature Range**
  - Operation (Standard): 0°C ~ 70°C
  - Operation (Wide): -40°C ~ 85°C
  - Storage: -40°C ~ 85°C
- **Compliant**
  - RoHS
  - CE & FCC

### Notes:

1. Please see "Power Consumption" for details.

# 1. INTRODUCTION

## 1.1. General Description

UDinfo M.2 2260 SATA Drive delivers all the advantages of Flash Disk technology with the Serial ATA I/II/III interface and is fully compliant with the standard *Next Generation Form Factor* (NGFF) called M.2 Card Format, which is generated by Intel. The M.2 2260 SATA Drive is designed to operate at a maximum operating frequency of 300MHz with 40MHz external crystal. Its capacity could provide a wide range up to 256GB. Moreover, it can reach up to 500MB/s read as well as 180MB/s write high performance based on Toshiba NAND flash (with 32MB SDR enabled and measured by CrystalDiskMark v3.0). The power consumption of the M.2 2260 is much lower than traditional Hard Drives, making it the best embedded solution for new plate forms.

## 1.2. Block Diagram

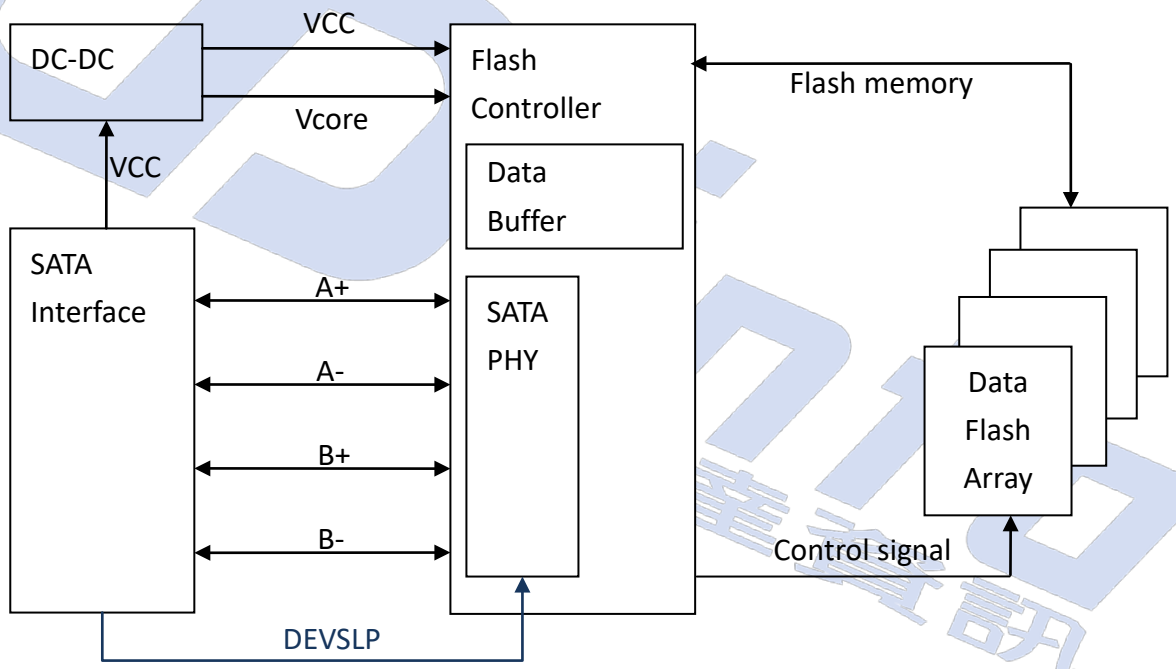

**M.2 2260 SATA Drive Block Diagram**

## 2. PRODUCT SPECIFICATIONS



- **Capacity**
  - SLC: From 1GB up to 64GB (support 48-bit addressing mode)
  - MLC: From 4GB up to 256GB (support 48-bit addressing mode)
  - pSLC: From 2GB up to 128GB (support 48-bit addressing mode)
- **Electrical/Physical Interface**
  - SATA Interface
    - ◆ Compliant with SATA Revision 3.0
    - ◆ Compatible with SATA 1.5Gbps, 3Gbps and 6Gbps interface
    - ◆ Support power management
    - ◆ Support expanded register for SATA protocol 48 bits addressing mode
    - ◆ Embedded BIST function for SATA PHY for low cost mass production
- **Supported NAND Flash**
  - Toshiba SLC and MLC, Toggle1.0 and Toggle2.0
  - Supports SLC large block 4K, 8K/page NAND flash
  - Supports MLC large block 16K/page NAND flash
- **ECC Scheme**
  - Up to 72 bits / 1K Byte
- **UART function**
- **GPIO**
- **Support SMART and TRIM commands**
- **Capacity Information**

Capacity	Cylinders	Heads	Sectors	Total Sectors	User Data Size
1GB	1,959	16	63	1,974,672	Depended on file management
2GB	3,897	16	63	3,928,176	
4GB	7,773	16	63	7,835,184	
8GB	15,525	16	63	15,649,200	
16GB	16,383	16	63	31,277,232	
32GB	16,383	16	63	62,533,296	
64GB	16,383	16	63	125,045,424	
128GB	16,383	16	63	250,069,680	
256GB	16,383	16	63	500,118,192	

- Performance

- SLC

Capacity	Flash Structure	Flash Type	Sequential	
			Read (MB/s)	Write (MB/s)
1GB	1GB x 1	32nm, TSOP	30	20
2GB	1GB x 2	32nm, TSOP	65	40
4GB	1GB x 4	32nm, TSOP	130	75
8GB	2GB x 4	32nm, TSOP	130	85
16GB	4GB x4	24nm,TSOP	130	95
	8GB X2	24nm,BGA	500	140
32GB	8GB x4	24nm,TSOP	130	100
	16GB x2	24nm,BGA	500	140
64GB	16GB x4	24nm,TSOP	130	100
	16GB x4	24nm,BGA	500	140

- MLC

Capacity	Flash Structure	Flash Type	Sequential	
			Read (MB/s)	Write (MB/s)
4GB	4GB x 1	15nm, TSOP	115	55
8GB	4GB x 2	15nm, TSOP	235	110
16GB	4GB x 4	15nm, TSOP	430	175
32GB	8GB x 4	15nm, TSOP	455	180
	16GB x 2		240	120
64GB	16GB x 4	15nm, TSOP	415	165
	32GB x2	15nm, BGA	475	175
128GB	64GB x 2	15nm, BGA	420	175
256GB	128GB x 2	15nm, BGA	430	175

- pSLC

Capacity	Flash Structure	Flash Type	Sequential	
			Read (MB/s)	Write (MB/s)
2GB	4GB x 1	15nm, TSOP	120	55
4GB	4GB x 2	15nm, TSOP	240	110
8GB	4GB x 4	15nm, TSOP	475	150
16GB	8GB x 4	15nm, TSOP	500	180
	16GB x 2		240	120
32GB	16GB x 4	15nm, TSOP	500	175
	32GB X2	15nm, BGA	500	180
64GB	64GB x 2	15nm, BGA	500	180
128GB	128GB x 2	15nm, BGA	500	175

**Notes:**

1. The performance was estimated based on Toshiba SLC and 15nm MLC NAND flash.
2. Performance may differ according to flash configuration and platform.
3. The table above is for reference only.

**UD info CORP. TEL: +886-2-7713-6050 FAX: +86-2-8511-3151**

3F-4, No.8, Ln. 609, Sec. 5, Chongxin Rd., Sanchong Dist., New Taipei City 241, Taiwan (R.O.C.)

● **TBW (Terabytes Written)**

■ SLC

Capacity	Flash Structure	TBW
1GB	1GB x 1	53
2GB	1GB x 2	107
4GB	1GB x 4	213
8GB	2GB x 4	427
16GB	4GB x4 8GB x2	862
32GB	8GB x4 16GB X2	1708
64GB	16GB x4	3448

■ MLC

Capacity	Flash Structure	TBW
4GB	4GB x 1	9
8GB	4GB x 2	19
16GB	4GB x 4	39
32GB	8GB x 4	79
64GB	16GB x 4 32GB x2	158
128GB	32GB x 4	317
256GB	64GB x 4	635

■ pSLC

Capacity	Flash Structure	TBW
2GB	4GB x 1	49
4GB	4GB x 2	99
8GB	8GB x 4	198
16GB	8GB x 4	397
32GB	16GB x 4 32GB x2	794
64GB	64GB x 2	1588
128GB	128GB x 2	3176

**Notes:**

1. Samples were built using Toshiba SLC and 15nm MLC NAND flash.
2. TBW may differ according to flash configuration and platform.
3. The endurance of SSD could be estimated based on user behavior, NAND endurance cycles, and write amplification factor. It is not guaranteed by flash vendor.

**UD info CORP. TEL: +886-2-7713-6050 FAX: +86-2-8511-3151**

3F-4, No.8, Ln. 609, Sec. 5, Chongxin Rd., Sanchong Dist., New Taipei City 241, Taiwan (R.O.C.)



### 3. ENVIRONMENTAL SPECIFICATIONS

#### 3.1. Environmental Conditions

##### 3.1.1. Temperature and Humidity

- Temperature:
  - ◆ Storage: -40°C to 85°C
  - ◆ Operational (Standard grade): 0°C to 70°C
  - ◆ Operational (Wide grade): -40°C to 85°C
- Humidity:
  - ◆ Standard grade: RH 90% under 40°C (operational)
  - ◆ Wide grade: RH 95% under 55°C (operational)

##### ■ High Temperature Test Condition

	Temperature	Humidity	Test Time
Operation (Standard)	70°C	0% RH	72 hours
Operation (Wide)	85°C	0% RH	72 hours
Storage (Standard)	85°C	0% RH	72 hours
Storage (Wide)	85°C	0% RH	168 hours

Result: No any abnormality is detected.

##### ■ Low Temperature Test Condition

	Temperature	Humidity	Test Time
Operation (Standard)	0°C	0% RH	72 hours
Operation (Wide)	-40°C	0% RH	72 hours
Storage (Standard)	-40°C	0% RH	72 hours
Storage (Wide)	-40°C	0% RH	168 hours

Result: No any abnormality is detected.

##### ■ High Humidity Test Condition

	Temperature	Humidity	Test Time
Operation (Standard)	40°C	93% RH	24 hours
Operation (Wide)	55°C	95% RH	72 hours
Storage (Standard)	40°C	95% RH	72 hours
Storage (Wide)	55°C	95% RH	96 hours

UD info CORP. TEL: +886-2-7713-6050 FAX: +86-2-8511-3151

3F-4, No.8, Ln. 609, Sec. 5, Chongxin Rd., Sanchong Dist., New Taipei City 241, Taiwan (R.O.C.)

Result: No any abnormality is detected.

■ Temperature Cycle Test

	Temperature	Test Time	Cycle
Operation (Standard)	0°C	30 min	10 cycles
	70°C	30 min	
Operation (Wide)	-40°C	30 min	20 cycles
	85°C	30 min	
Storage (Standard)	-40°C	30 min	10 cycles
	85°C	30 min	
Storage (Wide)	-40°C	30 min	50 cycles
	85°C	30 min	

Result: No any abnormality is detected.

3.1.2. Shock

■ Shock Specification

	Acceleration Force	Half Sin Pulse Duration
Operational	1500G	0.5ms

Result: No any abnormality is detected when power on.

3.1.3. Vibration

■ Vibration Specification

	Condition		Vibration Orientation
	Frequency/Displacement	Frequency/Acceleration	
Operational	20Hz~80Hz/1.52mm	80Hz~2000Hz/20G	X, Y, Z axis/60 min for each

Result: No any abnormality is detected when power on.

3.1.4. Drop

■ Drop Specification

	Height of Drop	Number of Drop
Non-operational	80cm free fall	6 face of each unit

Result: No any abnormality is detected when power on.

3.1.5. Bending

■ Bending Specification

	Force	Action
Non-operational	≥50N	Hold 1min/5times

Result: No any abnormality is detected when power on.

### 3.1.6. Torque

#### ■ Torque Specification

	Force	Action
Non-operational	0.5N-m or 5 deg	Hold 1min/5times

Result: No any abnormality is detected when power on.

### 3.1.7. Electrostatic Discharge (ESD)

#### ■ Contact ESD Specification

Device	Capacity	Temperature	Relative Humidity	+/- 4KV	Result
M.2 2260	64GB 128GB	24.0°C	49% (RH)	Device functions are affected, but EUT will be back to its normal or operational state automatically.	PASS

### 3.2. MTBF

MTBF, an acronym for Mean Time between Failures, is a measure of a device's reliability. Its value represents the average time between a repair and the next failure. The measure is typically in units of hours. The higher the MTBF value, the higher the reliability of the device. The predicted result of UDinfo's M.2 2260 SATA Drive is up to 3,000,000 hours.

### 3.3. Certification

- RoHS
- CE / FCC

### 3.4. Compliance

- SATA III (SATA Rev. 3.0)
- Up to ATA/ATAPI-8 (Including S.M.A.R.T)

## 4. ELECTRICAL SPECIFICATIONS



### 4.1. Supply Voltage

Parameter	Rating
Operating Voltage	3.3V

### 4.2. Power Consumption

#### ■ SLC

Capacity	Flash Structure	Flash Type	Read	Write	Partial	Slumber	Idle	DEVSLP
1GB	1GB x 1	32nm, TSOP	560	600	60	30	280	4.6
2GB	1GB x 2	32nm, TSOP	650	690	60	30	280	4.6
4GB	1GB x 4	32nm, TSOP	650	800	60	30	280	4.8
8GB	2GB x 4	32nm, TSOP	850	990	60	30	280	4.8
16GB	4GB x 4	24nm, TSOP	850	1000	60	30	280	4.8
	8GB x 2	24nm, BGA	980	930	80	30	280	4.9
32GB	8GB x 4	24nm, TSOP	900	1200	60	30	280	4.8
	16GB x 2	24nm, BGA	1200	1300	80	30	280	4.9
64GB	16GB x 4	24nm, TSOP	900	1200	60	30	280	4.8
	16GB x 4	24nm, BGA	1460	1480	80	30	280	4.9

Unit: mW

#### ■ MLC

Capacity	Flash Structure	Flash Type	Read	Write	Partial	Slumber	Idle	DEVSLP
4GB	4GB x 1	15nm, TSOP	705	690	35	55	280	4.9
8GB	4GB x 2	15nm, TSOP	870	860	35	55	285	4.9
16GB	4GB x 4	15nm, TSOP	1165	1040	65	44	325	4.9
32GB	8GB x 4	15nm, TSOP	1350	1300	55	34	310	4.9
	16GB x 2		1000	990	55	35	310	4.9
64GB	16GB x 4	15nm, TSOP	1250	1260	58	34	320	4.9
	32GB x 2	15nm, BGA	1610	1390	50	30	285	4.9
128GB	64GB x 2	15nm, BGA	1460	1540	52	31	285	4.9
256GB	128GB x 2	15nm, BGA	1540	1620	54	31	286	4.9

Unit: mW

■ pSLC

Capacity	Flash Structure	Flash Type	Read	Write	Partial	Slumber	Idle	DEVSLP
2GB	4GB x 1	15nm, TSOP	720	700	55	35	280	4.9
4GB	4GB x 2	15nm, TSOP	890	880	55	35	285	4.9
8GB	4GB x 4	15nm, TSOP	1195	1050	50	35	285	4.9
16GB	8GB x 4	15nm, TSOP	1400	1350	55	34	310	4.9
	16GB x 2		1000	990	55	35	310	4.9
32GB	16GB x 4	15nm, TSOP	1300	1280	56	36	310	4.9
	32GB x 2	15nm, BGA	1640	1420	50	30	285	4.9
64GB	64GB x 2	15nm, BGA	1490	1570	52	31	285	4.9
128GB	128GB x 2	15nm, BGA	1570	1650	54	31	286	4.9

Unit: mW

**NOTES:**

1. It's average value of power consumption based on 100% conversion efficiency.
2. The measured power voltage is 3.3V.
3. Samples were built using Toshiba NAND flash and measured under normal temperature.
4. Sequential R/W is measured while testing 4000MB sequential R/W 5 times by CrystalDiskMark. DEVSLP is measured while entering device sleep mode for 5 minutes.
5. Power Consumption may differ according to flash configuration, SDR configuration, or platform.

## 5. INTERFACE



### 5.1. Pin Assignment and Descriptions

Table 5-1 defines the signal assignment of the internal NGFF connector for SSD usage, described in the PCI Express M.2 Specification version 1.0 of the PCI-SIG.

Pin #	SATA Pin	Description
1	CONFIG_3 = GND	Ground
2	3.3V	Supply pin
3	GND	Ground
4	3.3V	Supply pin
5	N/C	No Connect
6	N/C	No Connect
7	N/C	No Connect
8	N/C	No Connect
9	N/C or GND <sup>Note</sup>	No Connect or Ground
10	DAS/DSS# (O) (OD)	Status indicators via LED devices that will be provided by the system Active Low. A pulled-up LED with series current limiting resistor should allow for 9mA when On.
11	N/C	No Connect
12	Module Key	
13	Module Key	
14	Module Key	
15	Module Key	
16	Module Key	
17	Module Key	
18	Module Key	
19	Module Key	
20	N/C	No Connect
21	CONFIG_0 = GND	Ground
22	N/C	No Connect
23	N/C	No Connect
24	N/C	No Connect
25	N/C	No Connect
26	N/C	No Connect
27	GND	Ground
28	N/C	No Connect

**UD info CORP. TEL: +886-2-7713-6050 FAX: +86-2-8511-3151**

3F-4, No.8, Ln. 609, Sec. 5, Chongxin Rd., Sanchong Dist., New Taipei City 241, Taiwan (R.O.C.)

Pin #	SATA Pin	Description
29	N/C	No Connect
30	N/C	No Connect
31	N/C	No Connect
32	N/C	No Connect
33	GND	Ground
34	N/C	No Connect
35	N/C	No Connect
36	N/C	No Connect
37	N/C	No Connect
38	DEVSLP (I) (0/3.3V)	Device Sleep, Input. When driven high the host is informing the SSD to enter a low power state
39	GND	Ground
40	N/C	No Connect
41	SATA-B+	SATA differential signals in the SATA specification
42	N/C	No Connect
43	SATA-B-	SATA differential signals in the SATA specification
44	N/C	No Connect
45	GND	Ground
46	N/C	No Connect
47	SATA-A-	SATA differential signals in the SATA specification
48	N/C	No Connect
49	SATA-A+	SATA differential signals in the SATA specification
50	N/C	No Connect
51	GND	Ground
52	N/C	No Connect
53	N/C	No Connect
54	N/C	No Connect
55	N/C	No Connect
56	Reserved for MFG Data	Manufacturing Data line. Used for SSD manufacturing only. Not used in normal operation. Pins should be left N/C in platform Socket.
57	GND	Ground
58	Reserved for MFG Clock	Manufacturing Clock line. Used for SSD manufacturing only. Not used in normal operation. Pins should be left N/C in platform Socket

**UD info CORP. TEL: +886-2-7713-6050 FAX: +86-2-8511-3151**

3F-4, No.8, Ln. 609, Sec. 5, Chongxin Rd., Sanchong Dist., New Taipei City 241, Taiwan (R.O.C.)

Pin #	SATA Pin	Description
59	Module Key	
60	Module Key	
61	Module Key	
62	Module Key	
63	Module Key	
64	Module Key	
65	Module Key	
66	Module Key	
67	N/C	No Connect
68	SUSCLK (I) (0/3.3V)	32kHz clock supply input that is provided by PCH to reduce power and cost for the module.
69	CONFIG_1 = GND	Defines module type
70	3.3V	Supply pin
71	GND	Ground
72	3.3V	Supply pin
73	GND	Ground
74	3.3V	Supply pin
75	CONFIG_2 = GND	Ground

**Note:** N/C for Socket 2, and GND for Socket 3.

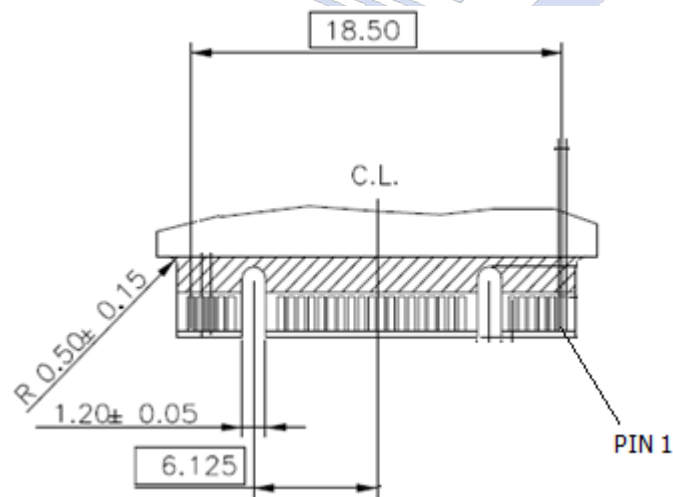



## 6. SUPPORTED COMMANDS



### 6.1. ATA Command List

Code	Description	Code	Description
00h	NOP	97h	IDLE
06h	Data Set Management	98h	CHECK POWER MODE
10h-1Fh	Recalibrate	99h	SLEEP
20h	Read Sectors	B0h	SMART
21h	Read Sectors without Retry	B1h	DEVICE CONFIGURATION
24h	Read Sectors EXT	C4h	Read Multiple
25h	Read DMA EXT	C5h	Write Multiple
27h	Read Native Max Address EXT	C6h	Set Multiple Mode
29h	Read Multiple EXT	C8h	Read DMA
2Fh	Read Log EXT	C9h	Read DMA without Retry
30h	Write Sectors	CAh	Write DMA
31h	Write Sectors without Retry	CBh	Write DMA without Retry
34h	Write Sectors EXT	CEh	Write Multiple FUA EXT
35h	Write DMA EXT	E0h	Standby Immediate
37h	Set Native Max Address EXT	E1h	Idle Immediate
38h	CFA WRITE SECTORS WITHOUT ERASE	E2h	Standby
39h	Write Multiple EXT	E3h	Idle
3Dh	Write DMA FUA EXT	E4h	Read Buffer
3Fh	Write Long EXT	E5h	Check Power Mode
40h	Read Verify Sectors	E6h	Sleep
41h	Read Verify Sectors without Retry	E7h	Flush Cache
42h	Read Verify Sectors EXT	E8h	Write Buffer
45h	WRITE UNCORRECTABLE EXT	EAh	Flush Cache EXT
60h	Read FPDMA Queued	ECh	Identify Device
61h	Write FPDMA Queued	EFh	Set Features
70h-7Fh	Seek	F1h	Security Set Password
90h	Execute Device Diagnostic	F2h	Security Unlock
91h	Initialize Device Parameters	F3h	Security Erase Prepare
92h	Download Microcode	F4h	Security Erase Unit
93h	DOWNLOAD MICROCODE DMA	F5h	Security Freeze Lock
94h	STANDBY IMMEDIATE	F6h	Security Disable Password
95h	IDLE IMMEDIATE	F8h	Read Native Max Address
96h	STANDBY	F9h	Set Max Address

## 6.2. Identify Device Data

The following table details the sector data returned by the IDENTIFY DEVICE command.

Word	F: Fixed V: Variable X: Both	Default Value	Description
0	F	0040h	General configuration bit-significant information
1	X	<b>*1</b>	Obsolete – Number of logical cylinders
2	V	C837h	Specific configuration
3	X	0010h	Obsolete – Number of logical heads (16)
4-5	X	00000000h	Retired
6	X	003Fh	Obsolete – Number of logical sectors per logical track (63)
7-8	V	00000000h	Reserved for assignment by the Compact Flash Association
9	X	0000h	Retired
10-19	F	Varies	Serial number (20 ASCII characters)
20-21	X	0000h	Retired
22	X	0000h	Obsolete
23-26	F	Varies	Firmware revision (8 ASCII characters)
27-46	F	Varies	Model number (xxxxxxxx)
47	F	8010h	7:0- Maximum number of sectors transferred per interrupt on MULTIPLE commands
48	F	4000h	Trusted Computing feature set options(not support)
49	F	2F00h	Capabilities
50	F	4000h	Capabilities
51-52	X	00000000h	Obsolete
53	F	0007h	Words 88 and 70:64 valid
54	X	<b>*1</b>	Obsolete – Number of logical cylinders
55	X	0010h	Obsolete – Number of logical heads (16)
56	X	003Fh	Obsolete – Number of logical sectors per track (63)
57-58	X	<b>*2</b>	Obsolete – Current capacity in sectors
59	F	0110h	Number of sectors transferred per interrupt on MULTIPLE commands
60-61	F	<b>*3</b>	Maximum number of sector ( 28bit LBA mode)
62	X	0000h	Obsolete
63	F	0407h	Multi-word DMA modes supported/selected

UD info CORP. TEL: +886-2-7713-6050 FAX: +86-2-8511-3151

3F-4, No.8, Ln. 609, Sec. 5, Chongxin Rd., Sanchong Dist., New Taipei City 241, Taiwan (R.O.C.)

Word	F: Fixed V: Variable X: Both	Default Value	Description
64	F	0003h	PIO modes supported
65	F	0078h	Minimum Multiword DMA transfer cycle time per word
66	F	0078h	Manufacturer's recommended Multiword DMA transfer cycle time
67	F	0078h	Minimum PIO transfer cycle time without flow control
68	F	0078h	Minimum PIO transfer cycle time with IORDY flow control
69	F	0100h	Additional Supported (support download microcode DMA)
70	F	0000h	Reserved
71-74	F	0000000000000000 0h	Reserved for the IDENTIFY PACKET DEVICE command
75	F	001Fh	Queue depth
76	F	670eh	Serial SATA capabilities
77	F	0084h	Serial ATA Additional Capabilities
78	F	014Ch	Serial ATA features supported
79	V	0040h	Serial ATA features enabled
80	F	07F8h	Major Version Number
81	F	0000h	Minor Version Number
82	F	346bh	Command set supported
83	F	7d09h	Command set supported
84	F	6063h	Command set/feature supported extension
85	V	3469h	Command set/feature enabled
86	V	bc01h	Command set/feature enabled
87	V	6063h	Command set/feature default
88	V	003Fh	Ultra DMA Modes
89	F	0001h	Time required for security erase unit completion
90	F	001Eh	Time required for Enhanced security erase completion
91	V	0000h	Current advanced power management value
92	V	FFFEh	Master Password Revision Code
93	F	0000h	Hardware reset result. The contents of the bits (12:0) of this word can be changed only during the execution of hardware reset.

Word	F: Fixed V: Variable X: Both	Default Value	Description
94	V	0000h	Vendor's recommended and actual acoustic management value
95	F	0000h	Stream Minimum Request Size
96	V	0000h	Streaming Transfer Time – DMA
97	V	0000h	Streaming Access Latency – DMA and PIO
98-99	F	0000h	Streaming Performance Granularity
100-103	V	<b>*4</b>	Maximum user LBA for 48 bit Address feature set
104	V	0000h	Streaming Transfer Time – PIO
105	F	0008h	Maximum number of 512-byte blocks per DATA SET MANAGEMENT command
106	F	4000h	Physical sector size/Logical sector size
107	F	0000h	Inter-seek delay for ISO-7779 acoustic testing in microseconds
108-111	F	0000000000000000 0h	Unique ID
112-115	F	0000000000000000 0h	Reserved
116	V	0000h	Reserved
117-118	F	00000000h	Words per logical Sector
119	F	4014h	Supported settings
120	F	4014h	Command set/Feature Enabled/Supported
121-126	F	0h	Reserved
127	F	0h	Removable Media Status Notification feature set support
128	V	0021h	Security status
129-140	X	0h	Vendor specific
141	X	0001h	Vendor specific
142-159	X	0h	Vendor specific
160	F	0h	Compact Flash Association (CFA) power mode 1
161-167	X	0h	Reserved for assignment by the CFA
168	F	3h 2.5 inch 4h 1.8 inch 5h Less than 1.8 inch	Device Nominal Form Factor

Word	F: Fixed V: Variable X: Both	Default Value	Description
169	F	0001h	DATA SET MANAGEMENT command is supported
170-173	F	0h	Additional Product Identifier
174-175		0h	Reserve
176-205	V	0h	Current media serial number
206	F	0h	SCT Command Transport
207-208	F	0h	Reserved
209	F	4000h	Alignment of logical blocks within a physical block
210-211	V	0000h	Write-Read-Verify Sector Count Mode 3 (not support)
212-213	F	0000h	Write-Read-Verify Sector Count Mode 2 (not support)
214-216		0000h	NV Cache relate (not support)
217	F	0001h	Non-rotating media device
218	F	0h	Reserved
219	F	0h	NV Cache relate (not support)
220	V	0h	Write read verify feature set current mode
221		0h	Reserved
222	F	107Fh	Transport major version number
223	F	0h	Transport minor version number
224-229		0h	reserved
230-233		0h	Extend number of user addressable sectors
234		0001h	Minimum number of 512-byte data blocks per DOWNLOAD MICROCODE command for mode 03h
235		0080h	Maximum number of 512-byte data blocks per DOWNLOAD MICROCODE command for mode 03h
236-254	F	0h	Reserved
255	X	XXA5h XX is variable	Integrity word (Checksum and Signature)

■ List of Device Identification for Each Capacity

Capacity (GB)	*1 (Word 1/Word 54)	*2 (Word 57–58)	*3 (Word 60–61)	*4 (Word 100–103)
1	7A7h	1E2190h	1E2190h	1E2190h
2	F39h	3BF070h	3BF070h	3BF070h
4	1E5Dh	778E30h	778E30h	778E30h
8	3CA5h	EEC9B0h	EEC9B0h	EEC9B0h
16	3FFFh	FBFC10h	1DD40B0h	1DD40B0h
32	3FFFh	FBFC10h	3BA2EB0h	3BA2EB0h
64	3FFFh	FBFC10h	7740AB0h	7740AB0h
128	3FFFh	FBFC10h	EE7C2B0h	EE7C2B0h
256	3FFFh	FBFC10h	FFFFFFh	1DCF32B0h



**7. PHYSICAL DIMENSION**



**Dimension: 60mm(L) x 22mm(W) x 3.75mm(H)**

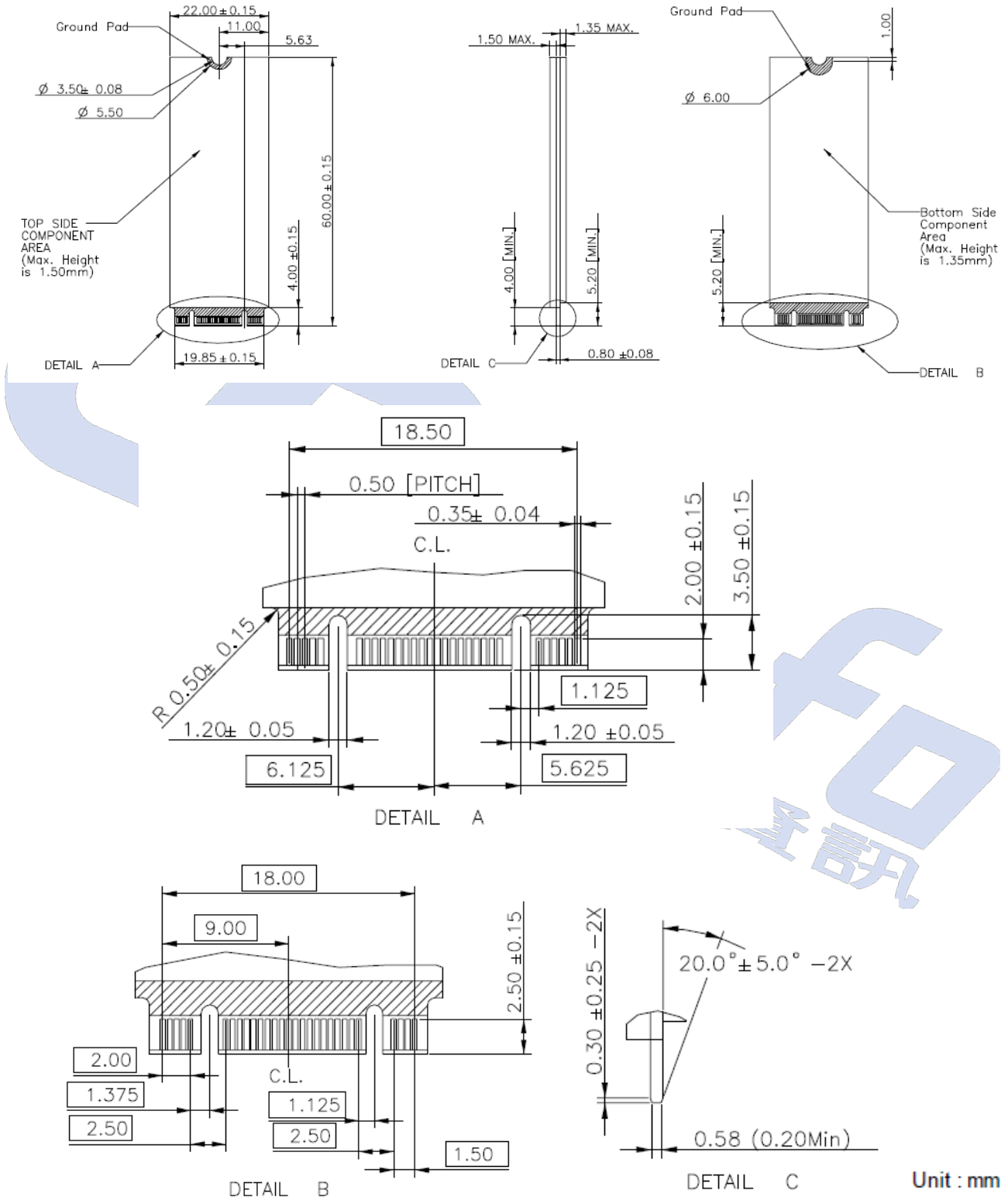

Unit : mm

## 8. TERMINOLOGY



The following table is to list out the acronyms that have been applied throughout the document.

Term	Definitions
ATTO	Commercial performance benchmark application
DEVSLP	Device Sleep Mode
DIPM	Device initiated power management
HIPM	Host initiated power management
LBA	Logical block addressing
MB	Mega-byte
MTBF	Mean time between failures
NCQ	Native command queue
SATA	Serial advanced technology attachment
SDR	Synchronous dynamic access memory
S.M.A.R.T.	Self-monitoring, analysis and reporting technology
SSD	Solid state disk

## 9. BARCODE DESCRIPTION

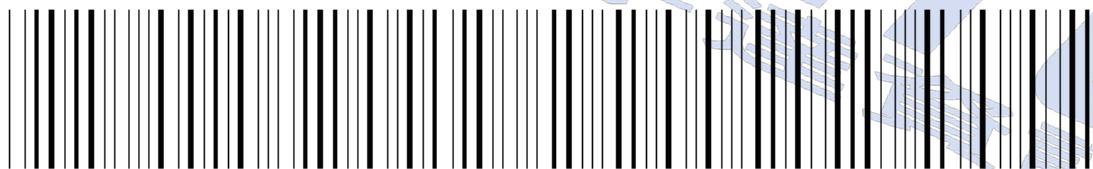

M 2 S 6 0 U D 2 5 6 G B C 4 P

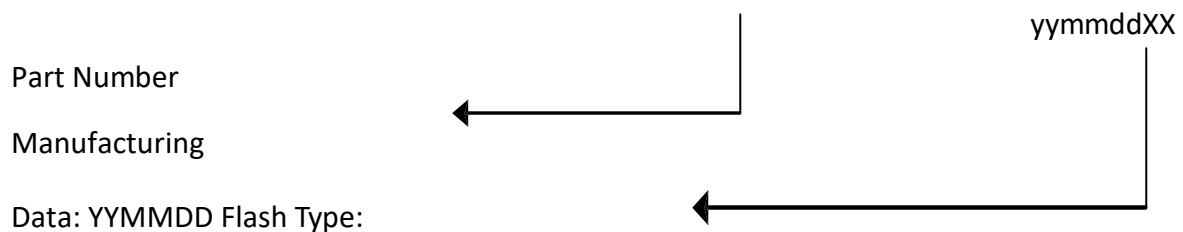



## 10. PARTNUMBER DECODER



M2S-60UDX<sup>8</sup>X<sup>9</sup>X<sup>10</sup>X<sup>11</sup>X<sup>12</sup>X<sup>13</sup>X<sup>14</sup>X<sup>15</sup>X<sup>16</sup>X<sup>17</sup>

X <sup>1</sup> X <sup>2</sup> X <sup>3</sup>	X <sup>4</sup> X <sup>5</sup>	X <sup>6</sup> X <sup>7</sup>	X <sup>8</sup> X <sup>9</sup> X <sup>10</sup> X <sup>11</sup> X <sup>12</sup>	X <sup>13</sup>	X <sup>14</sup>	X <sup>15</sup>	X <sup>16</sup> X <sup>17</sup>
M2S	60	UD	001GB      016GB 002GB      032GB 004GB      064GB 008GB      128GB 256GB	C: SLC Standard (0°C ~ +70°C) I: SLC Industrial (-40°C ~ +85°C) K: MLC Standard (0°C ~ +70°C) M: MLC Industrial (-40°C ~ +85°C) P: pSLC Standard (0°C ~ +70°C) F: pSLC Industrial (-40°C ~ +85°C)	4	P	blank

