

# UD info Corp.

Industrial M.2 2242 SATA Drive

M2S-42UB Series

Product DataSheet

**UD info CORP.**

3F-4, No.8, Ln. 609, Sec. 5, Chongxin Rd., Sanchong Dist., New Taipei City 241, Taiwan (R.O.C.)

TEL: +886-2-7713-6050 FAX: +886-2-8511-3151

E-mail: [sales@UDinfo.com.tw](mailto:sales@UDinfo.com.tw)

<b>1.</b>	<b>Introduction</b>	<b>5</b>
1.1.	General Description	5
1.2.	Block Diagram	5
<b>2.</b>	<b>Product Specifications</b>	<b>6</b>
<b>3.</b>	<b>Environmental Specifications</b>	<b>11</b>
3.1.	Environmental Conditions	11
3.1.1.	Temperature and Humidity	11
3.1.2.	Shock	12
3.1.3.	Vibration	12
3.1.4.	Drop	12
3.1.5.	Bending	12
3.1.6.	Electrostatic Discharge (ESD)	13
3.2.	MTBF	13
3.3.	Certification	13
3.4.	Compliance	13
<b>4.</b>	<b>Electrical Specifications</b>	<b>14</b>
4.1.	Supply Voltage	14
4.2.	Power Consumption	14
<b>5.</b>	<b>Interface</b>	<b>16</b>
5.1.	Pin Assignment and Descriptions	16
<b>6.</b>	<b>Supported Commands</b>	<b>19</b>
6.1.	ATA Command List	19
6.2.	Identify Device Data	21
<b>7.</b>	<b>Physical Dimension</b>	<b>26</b>
<b>8.</b>	<b>Terminology</b>	<b>27</b>
<b>9.</b>	<b>Barcode description</b>	<b>27</b>
<b>10.</b>	<b>Partnumber decoder</b>	<b>28</b>

## Revision History

Revision	Draft Date	History	Author
1.0	2016/11/10	New release	Golden Lee
1.1	2017/5/2	Add pSLC support	Golden Lee
1.2	2017/11/9	Modify TBW	Golden Lee
1.3	2017/11/21	Add 3D TLC Flash support	Golden Lee
1.4	2018/2/23	Update 3D TLC TBW	Golden Lee
1.5	2018/3/20	Update 3D TLC density support	Golden Lee
1.6	2018/4/11	Add SLC support	Golden Lee
1.7	2018/5/16	Add SLC 64GB support	Golden Lee
1.8	2018/6/28	Add SLC TBW data	Golden Lee
1.9	2018/8/17	Update 3D Bics3 TBW	Golden Lee
2.0	2018/8/31	Modify pSLC 32GB flash structure	Golden Lee
2.1	2019/1/18	Add P/N decoder for 3D wide temperature support	Golden Lee
2.2	2019/2/27	Modify pin68/69 description	Golden Lee



## Product Overview

- **Capacity**
  - MLC: 4GB up to 512GB
  - pSLC: 2GB up to 256GB
  - 3D Bics3: 32GB up to 512GB
  - SLC: 8GB up to 64GB
- **SATA Interface**
  - SATA Revision 3.2
  - SATA 1.5Gbps, 3Gbps, and 6Gbps interface
- **Flash Interface**
  - Flash Type: MLC, 3D Bics3 TLC, SLC
- **Performance**
  - Read up to 550 MB/s
  - Write up to 490 MB/s
- **Power Consumption**<sup>Note1</sup>
  - Active mode: <1,950mW
  - Idle mode: <325mW
- **TBW (Terabyte Written)**<sup>Note2</sup>
  - MLC: 540 TBW for 512GB
  - pSLC: 1,510 TBW for 256GB
  - 3D Bics3: 425 TBW for 512GB
  - SLC: 761 TBW for 64GB
- **MTBF**
  - MLC/3D Bics3: 2,000,000 hours
  - pSLC: 2,500,000 hours
  - SLC: 3,000,000 hours
- **Advanced Flash Management**
  - Static and Dynamic Wear Leveling
  - Bad Block Management
  - TRIM
  - SMART
  - Over-Provision
- **Low Power Management**
  - DEVSLP Mode (Optional)
  - DIPM/HIPM Mode
- **Temperature Range**
  - Operation (Standard): 0°C ~ 70°C
  - Operation (Wide): -40°C ~ 85°C
  - Storage: -40°C ~ 85°C
- **Compliant**
  - RoHS
  - CE & FCC

### Notes:

1. Please see "Power Consumption" for details.
2. Please see "TBW (Terabytes Written)" in Chapter 2 for details.

# 1. INTRODUCTION



## 1.1. General Description

UDinfo's M.2 2242 SATA Drive delivers all the advantages of Flash Disk technology with the Serial ATA I/II/III interface and is fully compliant with the standard *Next Generation Form Factor* (NGFF) called M.2 Card Format, which is generated by Intel. The M.2 2242 SATA Drive is designed to operate at a maximum operating frequency of 200MHz with 30MHz external crystal. Its capacity could provide a wide range up to 512GB. Moreover, it can reach up to 550MB/s read as well as 490MB/s write high performance based on Toshiba NAND flash (with 32MB SDR enabled and measured by CrystalDiskMark v5.0). The power consumption of the M.2 2242 is much lower than traditional Hard Drives, making it the best embedded solution for new platforms.

## 1.2. Block Diagram

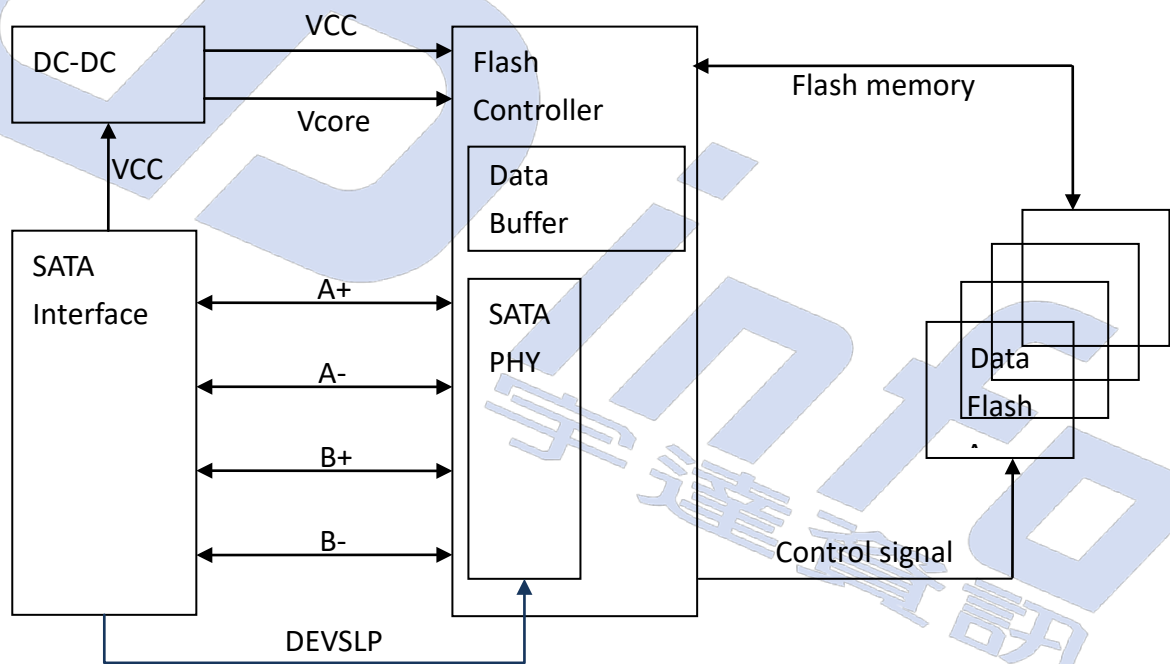

**M.2 2242 Block Diagram**

## 2. PRODUCT SPECIFICATIONS



- **Capacity**
  - MLC: From 4GB up to 512GB (support 48-bit addressing mode)
  - pSLC: From 2GB up to 256GB (support 48-bit addressing mode)
  - 3D Bics3: From 32GB up to 512GB (support 48-bit addressing mode)
  - SLC: From 8GB up to 64GB (support 48-bit addressing mode)
- **Electrical/Physical Interface**
  - SATA Interface
    - ◆ Compliant with SATA Revision 3.2
    - ◆ Compatible with SATA 1.5Gbps, 3Gbps and 6Gbps interface
    - ◆ Support power management
    - ◆ Support expanded register for SATA protocol 48 bits addressing mode
    - ◆ Embedded BIST function for SATA PHY for low cost mass production
- **Built-in 2-channel NAND flash interface controller**
  - Compliant with Toggle 1.0 and Toggle 2.0 NAND Flash interface
  - Compliant with ONFI 4.0 interface:
    - ◆ SDR up to mode 5
    - ◆ NV-DDR up to mode 5
    - ◆ NV-DDR2 up to mode 7
    - ◆ NV-DDR3 up to mode 8
- **Supported NAND Flash**
  - Support up to 16 Flash Chip Enables (CE) within single design
  - Toshiba 15nm/3D-NAND MLC and TLC
  - Support all types of SLC/MLC/TLC/3D-NAND, 8KB/page and 16K/page NAND flash
  - Support ONFI 2.3, ONFI 3.0, ONFI 3.2 and ONFI 4.0 interface: 2 channels at maximum
- **ECC Scheme**
  - Applies the LDPC (Low Density Parity Check) of ECC algorithm
- **UART function**
- **GPIO**
- **Support SMART and TRIM commands**

● Capacity Information

Capacity	Cylinders	Heads	Sectors	Total Sectors	User Data Size
2GB	3,897	16	63	3,928,176	Depended on file management
4GB	7,773	16	63	7,835,184	
8GB	15,525	16	63	15,649,200	
16GB	16,383	16	63	31,277,232	
30GB	16,383	16	63	58,626,288	
32GB	16,383	16	63	62,533,296	
60GB	16,383	16	63	117,231,408	
64GB	16,383	16	63	125,045,424	
120GB	16,383	16	63	234,441,648	
128GB	16,383	16	63	250,069,680	
240GB	16,383	16	63	468,862,128	
256GB	16,383	16	63	500,118,192	
480GB	16,383	16	63	937,703,088	
512GB	16,383	16	63	1,000,215,216	

● Performance

■ MLC:

Capacity	Flash Structure	Flash Type	Sequential	
			Read (MB/s)	Write (MB/s)
4GB	4GB x 1	15nm, TSOP	160	50
8GB	8GB x 1	15nm, TSOP	165	90
16GB	16GB x 1	15nm, TSOP	320	80
32GB	16GB x 2	15nm, TSOP	550	160
	32GB x 1	15nm, BGA	550	160
64GB	32GB x 2	15nm, BGA	550	310
128GB	64GB x 2	15nm, BGA	550	460
256GB	128GB x 2	15nm, BGA	550	460
512GB	256GB x 2	15nm, BGA	550	490

■ pSLC:

Capacity	Flash Structure	Flash Type	Sequential	
			Read (MB/s)	Write (MB/s)
2GB	4GB x 1	15nm, TSOP	160	50
4GB	8GB x 1	15nm, TSOP	165	90
8GB	16GB x 1	15nm, TSOP	300	80
16GB	16GB x 2	15nm, TSOP	550	160
	32GB x 1	15nm, BGA	550	160
32GB	32GB x 2	15nm, BGA	550	310
64GB	64GB x 2	15nm, BGA	550	460
128GB	128GB x 2	15nm, BGA	550	460
256GB	256GB x 2	15nm, BGA	550	490

■ 3D Bics3:

Capacity	Flash Structure	Flash Type	Sequential	
			Read (MB/s)	Write (MB/s)
32GB	32GB x 1	TSB Bics3, TSOP	300	120
64GB	32GB x 2	TSB Bics3, TSOP	550	250
128GB	64GB x 2	TSB Bics3, TSOP	550	450
		TSB Bics3, BGA	550	450
256GB	128GB x 2	TSB Bics3, BGA	550	490
512GB	256GB x 2	TSB Bics3, BGA	550	490

■ SLC:

Capacity	Flash Structure	Flash Type	Sequential	
			Read (MB/s)	Write (MB/s)
8GB	8GB x 1	24nm, BGA	320	70
16GB	8GB x 2	24nm, BGA	540	150
32GB	16GB x 2	24nm, BGA	510	300
64GB	32GB x 2	24nm, BGA	510	310

Notes:

1. The performance was estimated based on Toshiba NAND flash.
2. Performance may differ according to flash configuration and platform.
3. The table above is for reference only.



- **TBW (Terabytes Written)**

- **MLC:**

Capacity	Flash Structure	TBW
4GB	4GB x 1	1
8GB	8GB x 1	3
16GB	16GB x 1	6
32GB	32GB x 1	13
64GB	32GB x 2	30
128GB	64GB x 2	87
256GB	128GB x 2	198
512GB	256GB x 2	540

- **pSLC:**

Capacity	Flash Structure	TBW
2GB	4GB x 1	4
4GB	8GB x 1	10
8GB	16GB x 1	21
16GB	16GB x 2	49
32GB	32GB x 2	106
64GB	64GB x 2	215
128GB	128GB x 2	649
256GB	256GB x 2	1510

- **3D Bics3:**

Capacity	Flash Structure	TBW
32GB	32GB x 1	17
64GB	32GB x 2	42
128GB	64GB x 2	75
256GB	128GB x 2	180
512GB	256GB x 2	425

## ■ SLC:

Capacity	Flash Structure	TBW
8GB	8GB x 1	74
16GB	8GB x 2	153
32GB	16GB x 2	325
64GB	32GB x 2	761

**Notes:**

1. Samples were built using Toshiba NAND flash.
2. The test followed JEDEC219A client endurance workload.
3. TBW may differ according to flash configuration and platform.
4. The endurance of SSD could be estimated based on user behavior, NAND endurance cycles, and write amplification factor. It is not guaranteed by flash vendor.

### 3. ENVIRONMENTAL SPECIFICATIONS



#### 3.1. Environmental Conditions

##### 3.1.1. Temperature and Humidity

- Temperature:
  - ◆ Storage: -40°C to 85°C
  - ◆ Operational (Standard grade): 0°C to 70°C
  - ◆ Operational (Wide grade): -40°C to 85°C
- Humidity:
  - ◆ Standard grade: RH 90% under 40°C (operational)
  - ◆ Wide grade: RH 95% under 55°C (operational)

##### ■ High Temperature Test Condition

	Temperature	Humidity	Test Time
Operation (Standard)	70°C	0% RH	72 hours
Operation (Wide)	85°C	0% RH	72 hours
Storage (Standard)	85°C	0% RH	72 hours
Storage (Wide)	85°C	0% RH	168 hours

Result: No any abnormality is detected.

##### ■ Low Temperature Test Condition

	Temperature	Humidity	Test Time
Operation (Standard)	0°C	0% RH	72 hours
Operation (Wide)	-40°C	0% RH	72 hours
Storage (Standard)	-40°C	0% RH	72 hours
Storage (Wide)	-40°C	0% RH	168 hours

Result: No any abnormality is detected.

##### ■ High Humidity Test Condition

	Temperature	Humidity	Test Time
Operation (Standard)	40°C	93% RH	24 hours
Operation (Wide)	55°C	95% RH	72 hours
Storage (Standard)	40°C	95% RH	72 hours
Storage (Wide)	55°C	95% RH	96 hours

Result: No any abnormality is detected.

■ Temperature Cycle Test

	Temperature	Test Time	Cycle
Operation (Standard)	0°C	30 min	10 cycles
	70°C	30 min	
Operation (Wide)	-40°C	30 min	20 cycles
	85°C	30 min	
Storage (Standard)	-40°C	30 min	10 cycles
	85°C	30 min	
Storage (Wide)	-40°C	30 min	50 cycles
	85°C	30 min	

Result: No any abnormality is detected.

3.1.2. Shock

■ Shock Specification

	Acceleration Force	Half Sin Pulse Duration
Non-Operational	1500G	0.5ms
Operational	1500G	0.5ms

Result: No any abnormality is detected when power on.

3.1.3. Vibration

■ Vibration Specification

	Condition		Vibration Orientation
	Frequency/Displacement	Frequency/Acceleration	
Operational	20Hz~80Hz/1.52mm	80Hz~2000Hz/20G	X, Y, Z axis/60 min for each

Result: No any abnormality is detected when power on.

3.1.4. Drop

■ Drop Specification

	Height of Drop	Number of Drop
Non-operational	80cm free fall	6 face of each unit, 2 times

Result: No any abnormality is detected when power on.

3.1.5. Bending

■ Bending Specification

	Force	Action
Non-operational	≥20N	Hold 1min/5times

Result: No any abnormality is detected when power on.

### 3.1.6. Electrostatic Discharge (ESD)

#### ■ Contact ESD Specification

Device	Capacity	Temperature	Relative Humidity	+/- 4KV	Result
M.2 2242	256GB 512GB	24.0°C	49% (RH)	Device functions are affected, but EUT will be back to its normal or operational state automatically.	PASS

### 3.2. MTBF

MTBF, an acronym for Mean Time between Failures, is a measure of a device's reliability. Its value represents the average time between a repair and the next failure. The measure is typically in units of hours. The higher the MTBF value, the higher the reliability of the device. The predicted result of UDinfo's M.2 2242 is more than 3,000,000 hours.

### 3.3. Certification

- RoHS
- CE / FCC

### 3.4. Compliance

- SATA III (SATA Rev. 3.2)
- Up to ATA/ATAPI-8 (Including S.M.A.R.T)

## 4. ELECTRICAL SPECIFICATIONS



### 4.1. Supply Voltage

Parameter	Rating
Operating Voltage	3.3V , ±5%
Rise Time (Max/min)	100ms / 0.1ms
Fall Time (Max/min)	5s / 1ms

### 4.2. Power Consumption

#### ■ MLC

Capacity	Flash Structure	Flash Type	Read	Write	Partial	Slumber	Idle	DEVSLP
4GB	4GB x 1	15nm, TSOP	850	830	12.5	8	255	4.9
8GB	8GB x 1	15nm, TSOP	850	830	12.5	8	256	4.9
16GB	16GB x 1	15nm, TSOP	900	850	12.5	8	256	4.9
32GB	16GB x 2	15nm, TSOP	980	1100	13	9	260	4.9
	32GB x 1	15nm, BGA	1030	1210	12	7	255	4.9
64GB	32GB x 2	15nm, BGA	1040	1215	12	7	260	4.9
128GB	64GB x 2	15nm, BGA	1065	1480	12	7	255	4.9
256GB	128GB x 2	15nm, BGA	1165	1535	12	7	260	4.9
512GB	256GB x 2	15nm, BGA	1450	1740	16	10	265	4.9

Unit: mW

#### ■ pSLC

Capacity	Flash Structure	Flash Type	Read	Write	Partial	Slumber	Idle	DEVSLP
2GB	4GB x 1	15nm, TSOP	850	830	12.5	8	255	4.9
4GB	8GB x 1	15nm, TSOP	850	830	12.5	8	256	4.9
8GB	16GB x 1	15nm, TSOP	900	850	12.5	8	256	4.9
16GB	16GB x 2	15nm, TSOP	980	1100	13	9	260	4.9
	32GB x 1	15nm, BGA	1030	1210	12	7	255	4.9
32GB	32GB x 2	15nm, BGA	1040	1215	12	7	260	4.9
64GB	64GB x 2	15nm, BGA	1065	1480	12	7	255	4.9
128GB	128GB x 2	15nm, BGA	1165	1535	12	7	260	4.9
256GB	256GB x 2	15nm, BGA	1450	1740	16	10	265	4.9

Unit: mW

## ■ 3D Bics3

Capacity	Flash Structure	Flash Type	Read	Write	Partial	Slumber	Idle	DEVSLP
32GB	32GB x 1	TSB Bics3, TSOP	1100	1000	15	10	300	4.9
64GB	32GB x 2	TSB Bics3, TSOP	1215	1020	15	10	300	4.9
128GB	64GB x 2	TSB Bics3, TSOP	1300	1350	15	10	300	4.9
		TSB Bics3, BGA	1270	1360	20	15	325	4.9
256GB	128GB x 2	TSB Bics3, BGA	1360	1440	20	15	325	4.9
512GB	256GB x 2	TSB Bics3, BGA	1470	1520	22	15	325	4.9

Unit: mW

## ■ SLC

Capacity	Flash Structure	Flash Type	Read	Write	Partial	Slumber	Idle	DEVSLP
8GB	8GB x 1	24nm, BGA	1,200	1,000	20	15	315	4.9
16GB	8GB x 2	24nm, BGA	1,600	1,270	20	15	320	4.9
32GB	16GB x 2	24nm, BGA	1,650	1,700	20	15	325	4.9
64GB	32GB x 2	24nm, BGA	1,700	1,950	20	15	325	4.9

Unit: mW

### Notes:

1. It's average value of power consumption is achieved based on 100% conversion efficiency.
2. The measured power voltage is 3.3V.
3. Samples were built using Toshiba NAND flash and measured under normal temperature.
4. Sequential R/W is measured while testing 4000MB sequential R/W 5 times by CrystalDiskMark.
5. Power Consumption may differ according to flash configuration and platform.

## 5. INTERFACE



### 5.1. Pin Assignment and Descriptions

The follow table defines the signal assignment of the internal NGFF connector for SSD usage, described in the PCI Express M.2 Specification version 1.0 of the PCI-SIG.

Pin #	SATA Pin	Description
1	CONFIG_3 = GND	Ground
2	3.3V	Supply pin
3	GND	Ground
4	3.3V	Supply pin
5	N/C	No Connect
6	N/C	No Connect
7	N/C	No Connect
8	N/C	No Connect
9	N/C or GND <sup>Note</sup>	No Connect or Ground
10	DAS/DSS# (O) (OD)	Status indicators via LED devices that will be provided by the system Active Low. A pulled-up LED with series current limiting resistor should allow for 9mA when On.
11	N/C	No Connect
12	Module Key	
13	Module Key	
14	Module Key	
15	Module Key	
16	Module Key	
17	Module Key	
18	Module Key	
19	Module Key	
20	N/C	No Connect
21	CONFIG_0 = GND	Ground
22	N/C	No Connect
23	N/C	No Connect
24	N/C	No Connect
25	N/C	No Connect
26	N/C	No Connect
27	GND	Ground
28	N/C	No Connect

**UD info CORP. TEL: +886-2-7713-6050 FAX: +86-2-8511-3151**

3F-4, No.8, Ln. 609, Sec. 5, Chongxin Rd., Sanchong Dist., New Taipei City 241, Taiwan (R.O.C.)



Pin #	SATA Pin	Description
29	N/C	No Connect
30	N/C	No Connect
31	N/C	No Connect
32	N/C	No Connect
33	GND	Ground
34	N/C	No Connect
35	N/C	No Connect
36	N/C	No Connect
37	N/C	No Connect
38	DEVSLP (I) (0/3.3V)	Device Sleep, Input. When driven high the host is informing the SSD to enter a low power state
39	GND	Ground
40	N/C	No Connect
41	SATA-B+	SATA differential signals in the SATA specification
42	N/C	No Connect
43	SATA-B-	SATA differential signals in the SATA specification
44	N/C	No Connect
45	GND	Ground
46	N/C	No Connect
47	SATA-A-	SATA differential signals in the SATA specification
48	N/C	No Connect
49	SATA-A+	SATA differential signals in the SATA specification
50	N/C	No Connect
51	GND	Ground
52	N/C	No Connect
53	N/C	No Connect
54	N/C	No Connect
55	N/C	No Connect
56	Reserved for MFG Data	Manufacturing Data line. Used for SSD manufacturing only. Not used in normal operation. Pins should be left N/C in platform Socket.
57	GND	Ground
58	Reserved for MFG Clock	Manufacturing Clock line. Used for SSD manufacturing only. Not used in normal operation. Pins should be left N/C in platform Socket

**UD info CORP. TEL: +886-2-7713-6050 FAX: +86-2-8511-3151**

3F-4, No.8, Ln. 609, Sec. 5, Chongxin Rd., Sanchong Dist., New Taipei City 241, Taiwan (R.O.C.)

Pin #	SATA Pin	Description
59	Module Key	
60	Module Key	
61	Module Key	
62	Module Key	
63	Module Key	
64	Module Key	
65	Module Key	
66	Module Key	
67	N/C	No Connect
68	SUSCLK (I) (0/3.3V)	No Connect
69	CONFIG_1 = GND	Ground
70	3.3V	Supply pin
71	GND	Ground
72	3.3V	Supply pin
73	GND	Ground
74	3.3V	Supply pin
75	CONFIG_2 = GND	Ground

**Note:** N/C for Socket 2, and GND for Socket 3.



## 6. SUPPORTED COMMANDS



### 6.1. ATA Command List

Op-Code	Command Description	Op-Code	Command Description	
00h	NOP	60h	Read FPDMA Queued	
06h	Data Set Management	61h	Write FPDMA Queued	
10h	Recalibrate	70h	Seek	
20h	Read Sectors	90h	Execute Device Diagnostic	
21h	Read Sectors without Retry	91h	Initialize Device Parameters	
24h	Read Sectors EXT	92h	Download Microcode	
25h	Read DMA EXT	93h	Download Microcode DMA	
27h	Read Native Max Address EXT	B0h	SMART	
29h	Read Multiple EXT	B0h	D0h	SMART READ DATA
2Fh	Read Log EXT	B0h	D1h	SMART READ DATA ATTRIBUTE THRESHOLD
30h	Write Sectors	B0h	D2h	SMART ENABLE/DISABLE ATTRIBUTE AUTOSAVE
31h	Write Sectors without Retry	B0h	D3h	SMART SAVE ATTRIBUTE VALUES
34h	Write Sectors EXT	B0h	D4h	SMART EXECUTE OFF-LINE IMMEDIATE
35h	Write DMA EXT	B0h	D5h	SMART READ LOG
37h	Set Native Max Address EXT	B0h	D6h	SMART WRITE LOG
39h	Write Multiple EXT	B0h	D8h	SMART ENABLE OPERATIONS
3Dh	Write DMA FUA EXT	B0h	D9h	SMART DISABLE OPERATIONS
3Fh	Write Long EXT	B0h	DAh	SMART RETURN STATUS
40h	Read Verify Sectors	B0h	DBh	SMART ENABLE/DISABLE AUTOMATIC OFF-LINE
41h	Read Verify Sectors without Retry	B1h		DEVICE CONFIGURATION OVERLAY
42h	Read Verify Sectors EXT	B1h	C0h	DEVICE CONFIGURATION RESTORE
45h	Write Uncorrectable EXT	B1h	C1h	DEVICE CONFIGURATION FREEZE LOCK
47h	Read Log DMA EXT	B1h	C2h	DEVICE CONFIGURATION IDENTIFY
57h	Write Log DMA EXT	B1h	C3h	DEVICE CONFIGURATION SET
B1h	C4h	DEVICES CONFIGURATION IDENTIFY DMA	ECh	Identify Device
B1h	C5h	DEVICES CONFIGURATION SET DMA	EFh	Set Features
C4h	Read Multiple	EFh	02h	Enable 8-bit PIO transfer mode

**UD info CORP. TEL: +886-2-7713-6050 FAX: +86-2-8511-3151**

**3F-4, No.8, Ln. 609, Sec. 5, Chongxin Rd., Sanchong Dist., New Taipei City 241, Taiwan (R.O.C.)**

Op-Code		Command Description	Op-Code		Command Description
C5h		Write Multiple	EFh	03h	Set transfer mode based on value in Count field
C6h		Set Multiple Mode	EFh	05h	Enable advanced power management
C8h		Read DMA	EFh	10h	Enable use of Serial ATA feature
C9h		Read DMA without Retry	EFh	10h 02h	Enable DMA Setup FIS Auto-Activate optimization
CAh		Write DMA	EFh	10h 03h	Enable Device-initiated interface power state (DIPM) transitions
CBh		Write DMA without Retry	EFh	10h 06h	Enable Software Settings Preservation (SSP)
CEh		Write Multiple FUA EXT	EFh	10h 07h	Enable Device Automatic Partial to Slumber transitions
E0h		Standby Immediate	EFh	10h 09h	Enable Device Sleep
E1h		Idle Immediate	EFh	55h	Disable read look-ahead feature
E2h		Standby	EFh	66h	Disable reverting to power-on defaults
E3h		Idle	EFh	82h	Disable write cache
E4h		Read Buffer	EFh	85h	Disable advanced power management
E5h		Check Power Mode	EFh	90h	Disable use of Serial ATA feature set
E6h		Sleep	EFh	90h 02h	Disable DMA Setup FIS Auto-Activate optimization
E7h		Flush Cache	EFh	90h 03h	Disable Device-initiated interface power state (DIPM) transitions
E8h		Write Buffer	EFh	90h 06h	Disable Software Settings Preservation (SSP)
E9h		Read Buffer DMA	EFh	90h 07h	Disable Device Automatic Partial to Slumber transitions
EAh		Flush Cache EXT	EFh	90h 09h	Disable Device Sleep
EBh		Write Buffer DMA	EFh	AAh	Enable read look-ahead feature
EFh	CCh	Enable reverting to power-on defaults	F4h		Security Erase Unit
F1h		Security Set Password	F5h		Security Freeze Lock
F2h		Security Unlock	F6h		Security Disable Password
F3h		Security Erase Prepare	F8h		Read Native Max Address

## 6.2. Identify Device Data

The following table details the sector data returned by the IDENTIFY DEVICE command.

Word	F: Fixed V: Variable X: retired/obsolete /reserved	Default Value	Description
0	F	0040h	General configuration bit-significant information
1	X	*1	Obsolete – Number of logical cylinders
2	F	C837h	Specific configuration
3	X	0010h	Obsolete – Number of logical heads (16)
4-5	X	00000000h	Retired
6	X	003Fh	Obsolete – Number of logical sectors per logical track (63)
7-8	X	00000000h	Reserved for assignment by the Compact Flash Association
9	X	0000h	Retired
10-19	V	Varies	Serial number (20 ASCII characters)
20-21	X	0000h	Retired
22	X	0000h	Obsolete
23-26	V	Varies	Firmware revision (8 ASCII characters)
27-46	V	Varies	Model number (xxxxxxxx)
47	F	8010h	7:0- Maximum number of sectors transferred per interrupt on MULTIPLE commands
48	F	4000h	Reserved
49	F	2F00h	Capabilities
50	F	4000h	Capabilities
51-52	X	000000000h	Obsolete
53	F	0007h	Words 88 and 70:64 valid
54	X	*1	Obsolete – Number of logical cylinders
55	X	0010h	Obsolete – Number of logical heads (16)
56	X	003Fh	Obsolete – Number of logical sectors per track (63)
57-58	X	*2	Obsolete – Current capacity in sectors
59	F	0110h	Number of sectors transferred per interrupt on MULTIPLE commands
60-61	V	*3	Maximum number of sector ( 28bit LBA mode)
62	X	0000h	Obsolete
63	F	0407h	Multi-word DMA modes supported/selected

UD info CORP. TEL: +886-2-7713-6050 FAX: +86-2-8511-3151

3F-4, No.8, Ln. 609, Sec. 5, Chongxin Rd., Sanchong Dist., New Taipei City 241, Taiwan (R.O.C.)

Word	F: Fixed V: Variable X: retired/obsolete /reserved	Default Value	Description
64	F	0003h	PIO modes supported
65	F	0078h	Minimum Multiword DMA transfer cycle time per word
66	F	0078h	Manufacturer's recommended Multiword DMA transfer cycle time
67	F	0078h	Minimum PIO transfer cycle time without flow control
68	F	0078h	Minimum PIO transfer cycle time with IORDY flow control
69	F	1F00h	Additional Supported
70	X	0000h	Reserved
71-74	X	000000000000 0000h	Reserved for the IDENTIFY PACKET DEVICE command
75	F	001Fh	Queue depth
76	F	850Eh	Serial SATA capabilities
77	F	0006h	Supported Serial ATA Phy speed
78	F	004Ch	Serial ATA features supported
79	F	0040H	Serial ATA features enabled
80	F	0FF8h	Major Version Number
81	F	0000h	Minor Version Number
82	F	746Bh	Command set supported
83	F	7D01h	Command set supported
84	F	4163h	Command set/feature supported extension
85	F	7469h	Command set/feature supported or enabled
86	F	BC01h	Command set/feature supported or enabled
87	F	4163h	Command set/feature supported or enabled
88	F	007Fh	Ultra DMA Modes
89	F	000Ah	Time required for Normal Erase mode SECURITY ERASE UNIT command
90	F	001Eh	Time required for an Enhanced Erase mode SECURITY ERASE UNIT command
91	F	0000h	Current advanced power management value
92	F	FFFEh	Master Password Revision Code
93	F	0000h	Hardware reset result. The contents of the bits (12:0) of this word can be changed only during the execution of hardware

Word	F: Fixed V: Variable X: retired/obsolete /reserved	Default Value	Description
			reset.
94	X	0000h	Vendor's recommended and actual acoustic management value
95	F	0000h	Stream Minimum Request Size
96	F	0000h	Streaming Transfer Time – DMA
97	F	0000h	Streaming Access Latency – DMA and PIO
98-99	F	0000h	Streaming Performance Granularity
100-103	V	*4	Maximum user LBA for 48 bit Address feature set
104	F	0000h	Streaming Transfer Time – PIO
105	F	0008h	Maximum number of 512-byte blocks per DATA SET MANAGEMENT command
106	F	4000h	Physical sector size/Logical sector size
107	F	0000h	Inter-seek delay for ISO-7779 acoustic testing in microseconds
108-111	F	Varies	Reserved
112-115	X	000000000000 0000h	Reserved
116	X	0000h	Reserved
117-118	F	00000000h	Words per logical Sector
119	F	401Ch	Supported settings
120	F	401Ch	Command set/Feature Enabled/Supported
121-126	X	0h	Reserved
127	X	0h	Obsolete
128	F	0021h	Security status
129-159	V	Varies	Vendor specific
160	X	0h	Compact Flash Association (CFA) power mode 1
161-167	X	0h	Reserved for assignment by the CFA
168	V	Varies	Device Nominal Form Factor
169	F	0001h	DATA SET MANAGEMENT command is supported
170-173	F	0h	Additional Product Identifier
174-175	X	0h	Reserve
176-205	F	0h	Current media serial number
206	F	0039h	SCT Command Transport{



Word	F: Fixed V: Variable X: retired/obsolete /reserved	Default Value	Description
207-208	X	0h	Reserved
209	F	4000h	Alignment of logical blocks within a physical block
210-211	F	0000h	Write-Read-Verify Sector Count Mode 3 (not support)
212-213	F	0000h	Write-Read-Verify Sector Count Mode 2 (not support)
214-216	X	0000h	NV Cache relate (not support)
217	F	0001h	Non-rotating media device
218	X	0h	Reserved
219	X	0h	NV Cache relate (not support)
220	V	0h	Write read verify feature set current mode
221	X	0h	Reserved
222	F	10FFh	Transport major version number
223	F	0h	Transport minor version number
224-229	X	0h	reserved
230-233	F	0h	Extend number of user addressable sectors
234	F	0001h	Minimum number of 512-byte data blocks per DOWNLOAD MICROCODE command for mode 03h
235	F	FFFEh	Maximum number of 512-byte data blocks per DOWNLOAD MICROCODE command for mode 03h
236-242	X	0h	Reserved
243	X	0000h	Reserved
244-254	X	0h	Reserved
255	F	XXA5h XX is variable	Integrity word (Checksum and Signature)



■ List of Device Identification for Each Capacity

Capacity (GB)	*1 (Word 1/Word 54)	*2 (Word 57–58)	*3 (Word 60–61)	*4 (Word 100–103)
2	F39h	3BF070h	3BF070h	3BF070h
4	1E5Dh	778E30h	778E30h	778E30h
8	3CA5h	EEC9B0h	EEC9B0h	EEC9B0h
16	3FFFh	FBFC10h	1DD40B0h	1DD40B0h
30	3FFFh	FBFC10h	37E90F0h	37E90F0h
32	3FFFh	FBFC10h	3BA2EB0h	3BA2EB0h
60	3FFFh	FBFC10h	6FCCF30h	6FCCF30h
64	3FFFh	FBFC10h	7740AB0h	7740AB0h
120	3FFFh	FBFC10h	DF94BB0h	DF94BB0h
128	3FFFh	FBFC10h	EE7C2B0h	EE7C2B0h
240	3FFFh	FBFC10h	0FFFFFFFh	1BF244B0h
256	3FFFh	FBFC10h	0FFFFFFFh	1DCF32B0h
480	3FFFh	FBFC10h	0FFFFFFFh	37E436B0
512	3FFFh	FBFC10h	0FFFFFFFh	3B9E12B0h



**7. PHYSICAL DIMENSION**



Dimension: 42mm(L) x 22mm(W) x 3.8mm(H)

Unit : mm

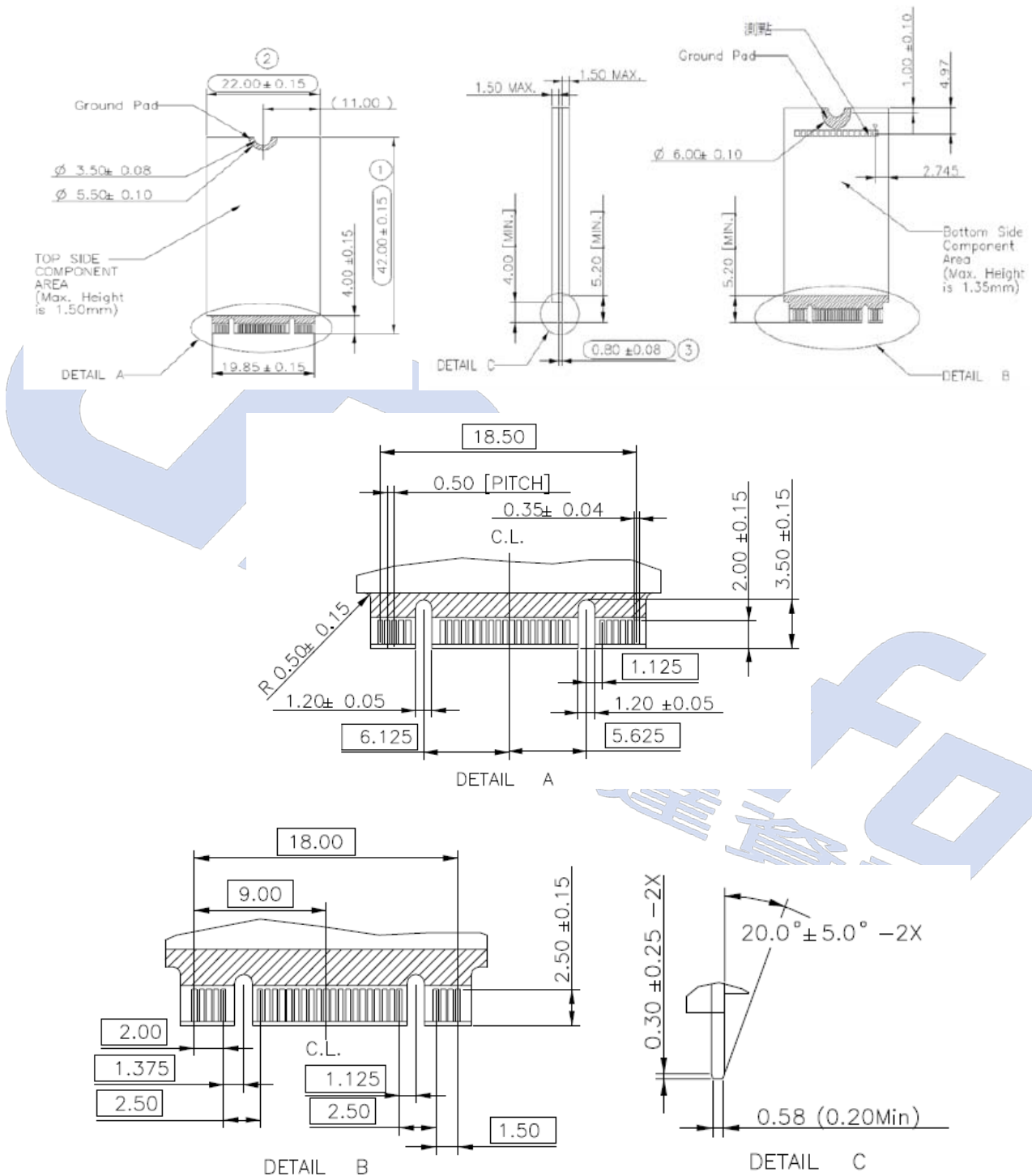

**UD info CORP. TEL: +886-2-7713-6050 FAX: +86-2-8511-3151**

**3F-4, No.8, Ln. 609, Sec. 5, Chongxin Rd., Sanchong Dist., New Taipei City 241, Taiwan (R.O.C.)**

## 8. TERMINOLOGY



The following table is to list out the acronyms that have been applied throughout the document.

Term	Definitions
ATTO	Commercial performance benchmark application
DEVSLP	Device Sleep Mode
DIPM	Device initiated power management
HIPM	Host initiated power management
LBA	Logical block addressing
MB	Mega-byte
MTBF	Mean time between failures
NCQ	Native command queue
SATA	Serial advanced technology attachment
SDR	Synchronous dynamic access memory
S.M.A.R.T.	Self-monitoring, analysis and reporting technology
SSD	Solid state disk

## 9. BARCODE DESCRIPTION

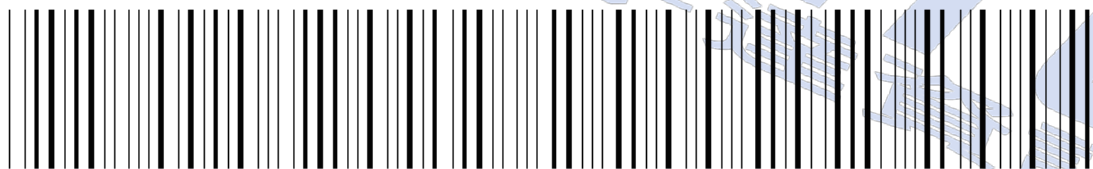

M 2 S 4 2 U B 5 1 2 G B K 2 P

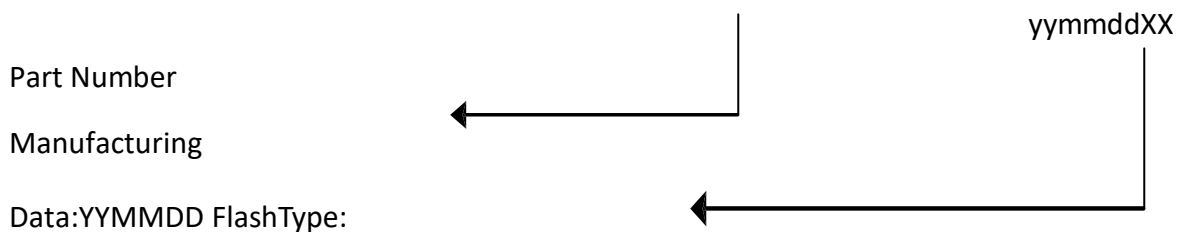

## 10. PARTNUMBER DECODER



M2S-42UBX<sup>8</sup>X<sup>9</sup>X<sup>10</sup>X<sup>11</sup>X<sup>12</sup>X<sup>13</sup>X<sup>14</sup>X<sup>15</sup>X<sup>16</sup>X<sup>17</sup>

X <sup>1</sup> X <sup>2</sup> X <sup>3</sup>	X <sup>4</sup> X <sup>5</sup>	X <sup>6</sup> X <sup>7</sup>	X <sup>8</sup> X <sup>9</sup> X <sup>10</sup> X <sup>11</sup> X <sup>12</sup>		X <sup>13</sup>	X <sup>14</sup>	X <sup>15</sup>	X <sup>16</sup> X <sup>17</sup>
M2S	42	UB	002GB	064GB	C: SLC Standard (0°C ~ +70°C)	2	P	blank
			004GB	120GB	I: SLC Industrial (-40°C ~ +85°C)			
			008GB	128GB	K: MLC Standard (0°C ~ +70°C)			
			016GB	240GB	M: MLC Industrial (-40°C ~ +85°C)			
			030GB	256GB	P: pSLC Standard (0°C ~ +70°C)			
			032GB	480GB	F: pSLC Industrial (-40°C ~ +85°C)			
			060GB	512GB	A: 3D TLC Standard (0°C ~ +70°C)			
					B: 3D TLC Industrial (-40°C ~ +85°C)			