



# SOLUTIONS

DISPLAYS | TOUCH | EMBEDDED

## TFT-Display Datasheet

# LM270WR5-SSA1 | LG Display

### Features

■ Active Screen Area	596.74x335.66 [mm]
■ Size   Format	27"   16:9
■ Resolution	3840x2160
■ Backlight	LED
■ Brightness	350 cd/m <sup>2</sup>
■ LED Life Time	30K (h)
■ Interface	eDP
■ Viewing Angle	L/R 89/89 - U/D 89/89
■ Touchscreen	no
■ Power Supply	10.0V [Typ.]
■ Module Outline	608.6x349.0x13.3 [mm]
■ Operation Temperature	-0... + 50°C
■ Storage Temperature	-20... + 60°C

### Contact

HY-LINE Computer Components  
Vertriebs GmbH  
Inselkammerstr. 10  
82008 Unterhaching  
Germany

### Support

**Tel.: +49 89 614 503 40**  
**Fax. +49 89 614 503 50**

Send us an email  
[computer@hy-line.de](mailto:computer@hy-line.de)



**Product Specification**
Contents

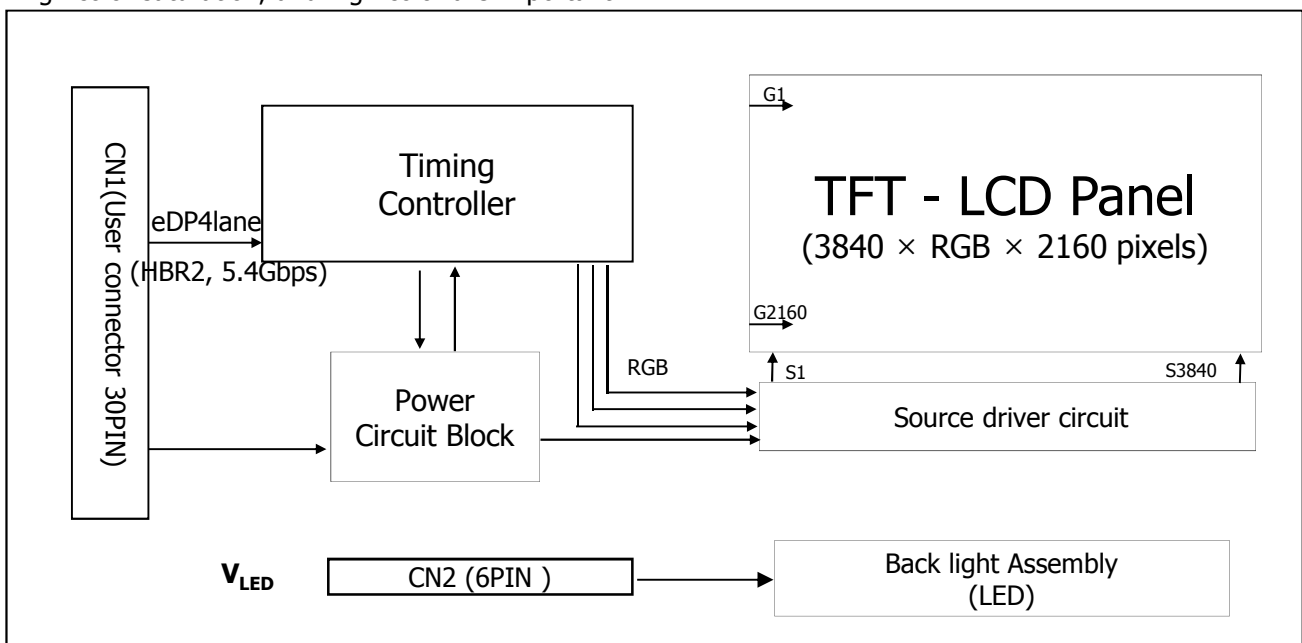
No	ITEM	Page
	COVER	1
	CONTENTS	2
	RECORD OF REVISIONS	3
1	GENERAL DESCRIPTION	4
2	ABSOLUTE MAXIMUM RATINGS	5
3	ELECTRICAL SPECIFICATIONS	6
3-1	ELECTRICAL CHARACTERISTICS	6
3-2	INTERFACE CONNECTIONS	9
3-3	LVDS CHARACTERISTICS	12
3-4	SIGNAL TIMING SPECIFICATIONS	15
3-5	SIGNAL TIMING WAVEFORMS	16
3-6	COLOR INPUT DATA REFERENCE	17
3-7	POWER SEQUENCE & DIP CONDITION FOR LCD MODULE	18
4	OPTICAL SPECIFICATIONS	20
5	MECHANICAL CHARACTERISTICS	25
6	RELIABILITY	28
7	INTERNATIONAL STANDARDS	29
7-1	SAFETY	29
7-2	EMC	29
7-3	ENVIRONMENT	29
8	PACKING	30
8-1	DESIGNATION OF LOT MARK	30
8-2	PACKING FORM	30
9	PRECAUTIONS	31



Product Specification

### 1. General Description

LM270WR5 is a Color Active Matrix Liquid Crystal Display with a Light Emitting Diode (LED) backlight system without LED driver. The matrix employs a-Si Thin Film Transistor as the active element. It is a transmissive type display operating in the normally black mode. It has a 27 inch diagonally measured active display area with UHD resolution (3840 horizontal by 2160 vertical pixel array) Each pixel is divided into Red, Green and Blue sub-pixels or dots which are arranged in vertical stripes. Gray scale or the brightness of the sub-pixel color is determined with a 10-bit gray scale signal for each dot, thus, presenting a palette of more than 1.07Billion colors with A-FRC (Advanced Frame Rate Control). It has been designed to apply eDP(HBR2, 5.4Gbps) interface. It is intended to support displays where high brightness, super wide viewing angle, high color saturation, and high color are important.



[ FIG.1 ] Block diagram

### General Features

Active Screen Size	27 inches(68.47cm) diagonal
Outline Dimension	608.6(H) x 349(V) x 13.3(D) mm (Typ.)
Pixel Pitch	0.1554 mm x 0.1554 mm
Pixel Format	3840 horiz. By 2160 vert. Pixels RGB stripes arrangement
Color Depth	1.07 Billion colors, 10Bit (8Bit + A-FRC)
Luminance, White	350 cd/m <sup>2</sup> ( Center 1 Point, Typ.)
Viewing Angle(CR>10)	View Angle Free (R/L 178(Typ.), U/D 178(Typ.))
Power Consumption	Total 31.8 Watt (Typ.) (6.6 Watt @V <sub>LCD</sub> , 25.2 Watt @I <sub>s</sub> = 130 mA)
Weight	2,266g (Typ.) / 2,379g (Max.)
Display Operating Mode	Transmissive mode, normally black
Surface Treatment	Advanced Anti-glare treatment of the front polarizer (3H)

Product Specification

**2. Absolute Maximum Ratings**

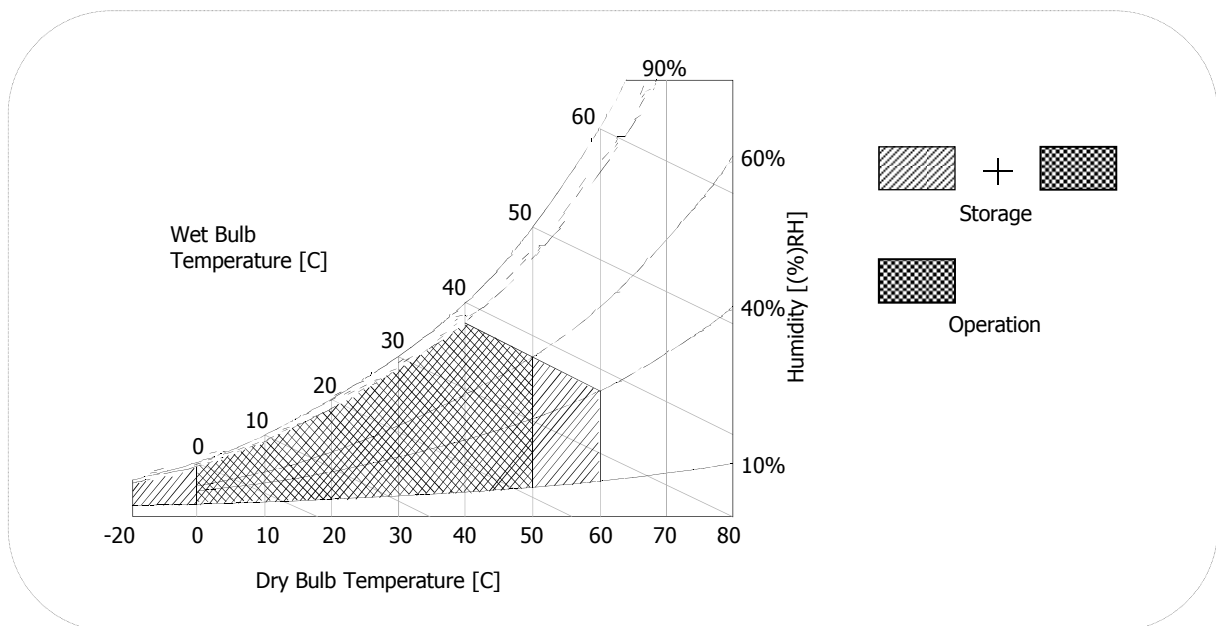
The following are maximum values which, if exceeded, may cause faulty operation or damage to the unit.

**Table 1. ABSOLUTE MAXIMUM RATINGS**

Parameter	Symbol	Values		Units	Notes
		Min	Max		
Power Input Voltage	V <sub>LCD</sub>	-0.3	12	V <sub>dc</sub>	at 25 ± 2°C
Operating Temperature	T <sub>OP</sub>	0	50	°C	1, 2, 3
Storage Temperature	T <sub>ST</sub>	-20	60	°C	
Operating Ambient Humidity	H <sub>OP</sub>	10	90	%RH	
Storage Humidity	H <sub>ST</sub>	10	90	%RH	
LCM Surface Temperature (Operation)	T <sub>Surface</sub>	0	65	°C	1,4

- Note : 1. Temperature and relative humidity range are shown in the figure below.  
 Wet bulb temperature should be 39 °C Max, and no condensation of water.  
 2. Maximum Storage Humidity is up to 40°C, 70% RH only for 4 corner light leakage Mura.  
 3. Storage condition is guaranteed under packing condition  
 4. LCM Surface Temperature should be Min. 0°C and Max. 65°C under the V<sub>LCD</sub>=10.0V, f<sub>V</sub>=60Hz, 25°C ambient Temp. no humidity control and LED string current is typical value.

**FIG.2 Temperature and relative humidity**



**Product Specification**
**3. Electrical Specifications**
**3-1. Electrical Characteristics**

It requires two power inputs. One is employed to power the LCD electronics and to drive the TFT array and liquid crystal. The second input power for the LED/Backlight, is typically generated by a LED Driver. The LED Driver is an external unit to the LCDs.

**Table 2-1. ELECTRICAL CHARACTERISTICS**

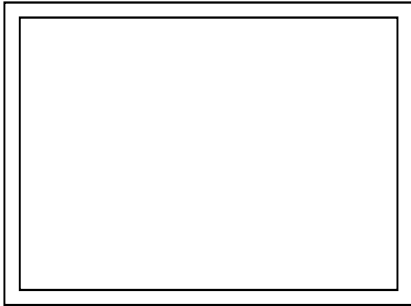
Parameter	Symbol	Values			Unit	Notes
		Min	Typ	Max		
MODULE :						
Power Supply Input Voltage	V <sub>LCD</sub>	9.5	10.0	10.5	Vdc	5
Permissive Power Input Ripple	V <sub>dRF</sub>			400	mV <sub>p-p</sub>	1
Power Supply Input Current	I <sub>LCD</sub>	-	660	825	mA	2
		-	920	1150	mA	3
Power Consumption	P <sub>c</sub> TYP	-	6.6	8.25	Watt	2
	P <sub>c</sub> MAX	-	9.2	11.5	Watt	3
Rush current	I <sub>RUSH</sub>	-		3	A	4

Note :

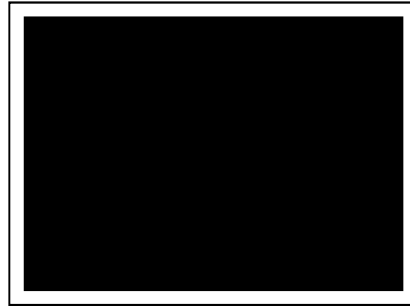
1. Permissive power ripple should be measured under V<sub>LCD</sub>=10.0V, 25 ± 2°C, f<sub>V</sub>=60Hz condition and at that time, we recommend the bandwidth configuration of oscilloscope is to be under 20Mhz.
2. The specified current and power consumption are under the V<sub>LCD</sub>=10.0V, 25 ± 2°C, f<sub>V</sub>=60Hz condition whereas mosaic pattern(8 x 6) is displayed and f<sub>V</sub> is the frame frequency.
3. The current is specified at the maximum current pattern.
4. The duration of rush current is about 2ms and rising time of power Input is 1ms(min.).
5. V<sub>LCD</sub> level must be measured at two points on LCM PCB - between V<sub>LCD</sub>(test point) and LCM Ground. The measured results need to meet the Power supply input voltage spec.  
(Test condition : maximum power pattern , 25± 2°C, f<sub>V</sub>=60Hz)

Product Specification

- **Permissive Power input ripple** ( $V_{LCD} = 10.0V$ ,  $25^{\circ}C$ ,  $f_v$  (frame frequency)=Max. condition)

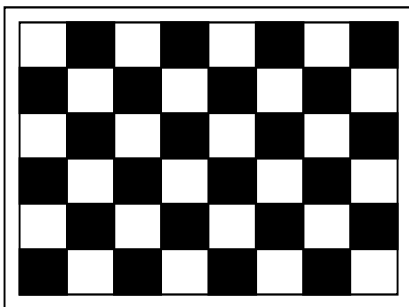


White pattern

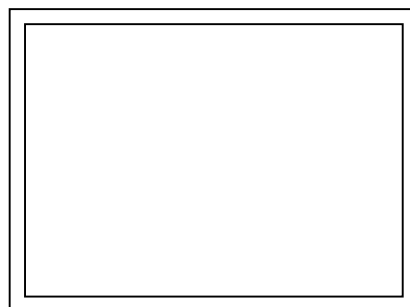


Black pattern

- **Power consumption** ( $V_{LCD} = 10V$ ,  $25^{\circ}C$ ,  $f_v$  (frame frequency)=60Hz condition)



Typical power Pattern



Maximum power Pattern

**FIG.3 Mosaic pattern & White Pattern for power consumption measurement**





Product Specification

**3-2. Interface Connections**

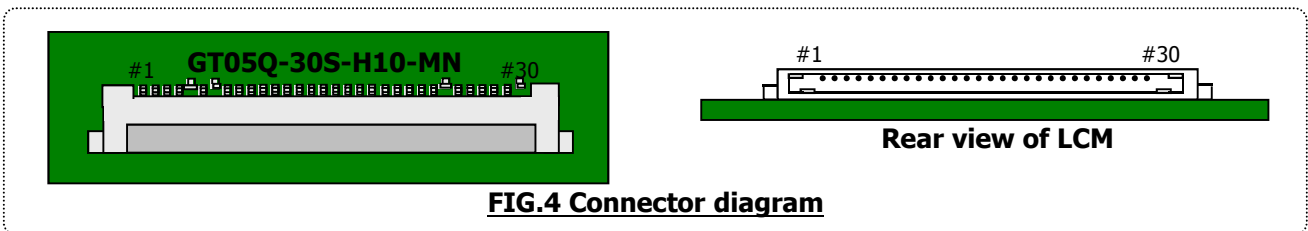
**3-2-1. LCD Module**

- LCD Connector(CN1) : GT05Q-30S-H10-MN (LSMtron), HD2S030HA1 (JAE), KN38B-30S-0.5H(HIROSE) or Equivalent
- Mating Connector : 20453-030T-## (Manufactured by I-PEX) or Equivalent

**Table 3. MODULE CONNECTOR(CN1) PIN CONFIGURATION**

No	Symbol	Description	No	Symbol	Description
1	VLCD	Power Supply +10.0V	16	Lane0P	True Signal for Main Link 0
2	VLCD	Power Supply +10.0V	17	Lane0N	Component Signal for Main Link 0
3	VLCD	Power Supply +10.0V	18	GND	Ground
4	VLCD	Power Supply +10.0V	19	Lane1P	True Signal for Main Link 1
5	VLCD	Power Supply +10.0V	20	Lane1N	Component Signal for Main Link 1
6	NC	No connection	21	GND	Ground
7	GND	Ground	22	Lane2P	True Signal for Main Link 2
8	NC	No Connection	23	Lane2N	Component Signal for Main Link 2
9	NC	No Connection	24	GND	Ground
10	GND	Ground	25	Lane3P	True Signal for Main Link 3
11	HPD	Hot Plug Detect Signal	26	Lane3N	Component Signal for Main Link 3
12	GND	Ground	27	GND	Ground
13	AUX_CHN	Component Signal for Auxiliary Channel	28	GND	Ground
14	AUX_CHP	True Signal for Auxiliary Channel	29	NC	No Connection
15	GND	Ground	30	GND	Ground

- Note: 1. All GND(ground) pins should be connected together and to Vss which should also be connected to the LCD's metal frame.  
 2. All VLCD (power input) pins should be connected together.

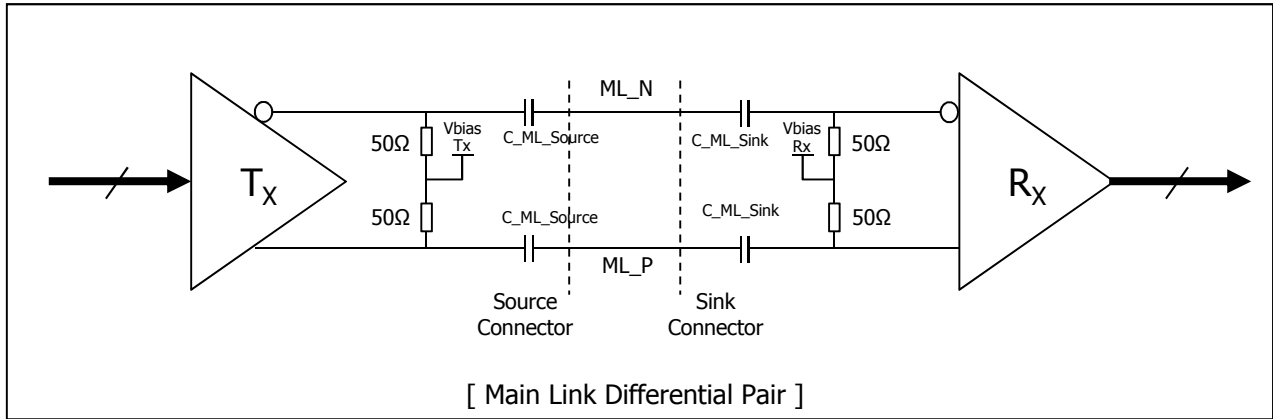




Product Specification

3-3. eDP Signal Specifications

3-3-1. eDP Main Link Signal



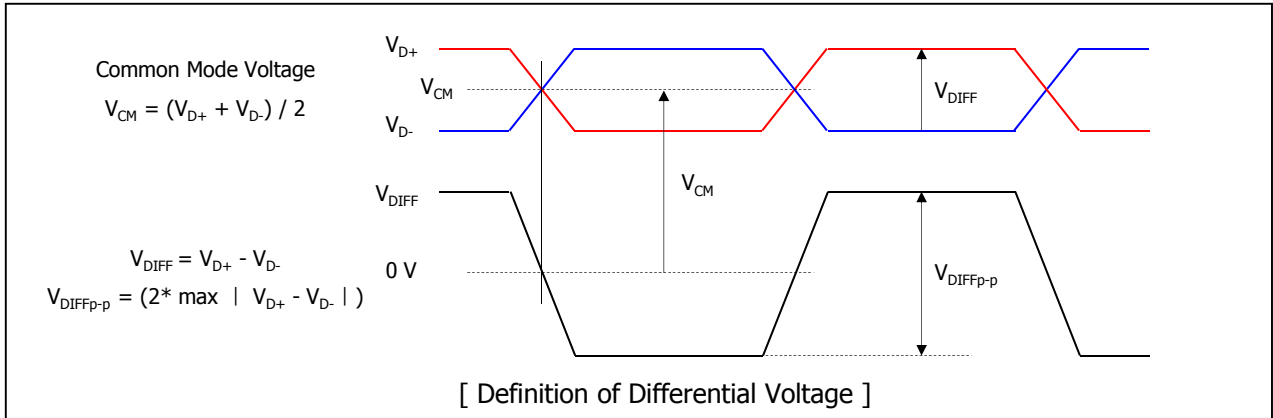
Parameter	Symbol	Min	Typ	Max	Unit	Notes
Unit Interval for high bit rate (5.4Gbps / lane)	UI_HBR2	-	185	-	ps	
Link Clock Down Spreading	Amplitude	0	-	0.5	%	
	Frequency	30		33	kHz	
Differential peak-to-peak voltage at Sink side connector	$V_{RX-DIFFP-P}$	-	-	1.38	V	Note 6,7)
EYE width at Sink side connector	$T_{RX-EYE-CONN}$	0.38	-	-	UI	Note 6,7)
Lane-to-Lane skew	$L_{RX-SKEW-INTER\_PAIR}$	-	-	4UI+ 500ps		
Lane intra-pair skew	$L_{RX-SKEW-INTRA\_PAIR}$	-	-	50	ps	
AC Coupling Capacitor	$C_{SOURCE-ML}$	75		200	nF	Source side

Note)

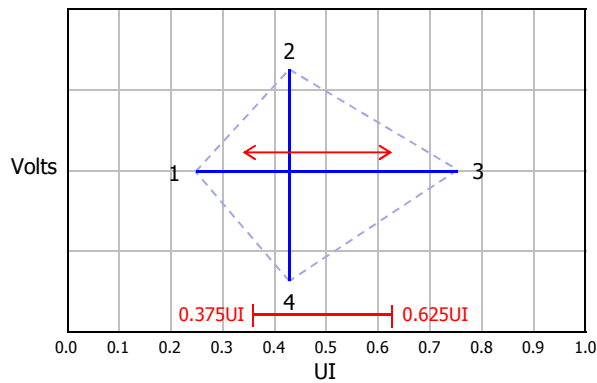
1. Termination resistor is typically integrated into the transmitter and receiver implementations.
2. In cabled embedded system, it is recommended the system designer ensure that EYE width and voltage are met at the sink side connector pins.
3. Mismatched common mode voltage will occur abnormal display.
4. All eDP electrical spec is measured at sink connector side.
5. eDP cable Impedance should be 100ohm ± 5%.

**Product Specification**

**Note6) Definition of Differential Voltage**



**Note7) Main Link EYE Diagram**

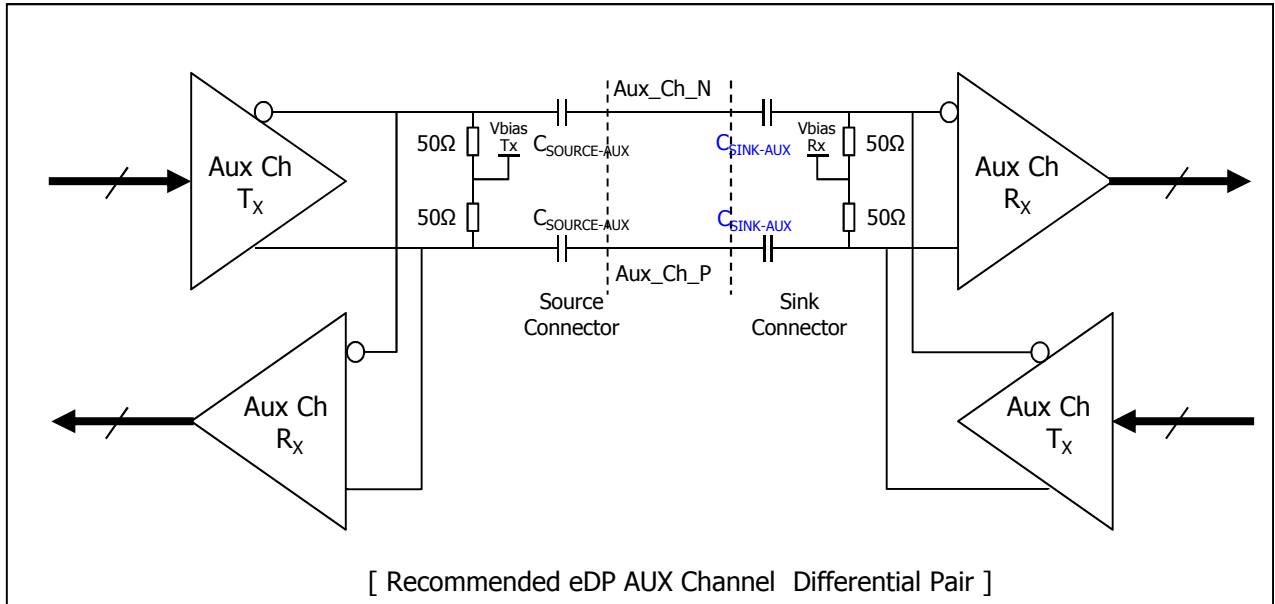


Point	High Bit Rate 2 @ TP3 EQ	
	Time(UI)	Voltage(V)
1	Any UI location (x) where the eye width is open from x to x+0.38UI	0.000
2	Any passing UI location between 0.375UI-0.625UI	0.045
3	Point 1 + 0.38UI	0.000
4	Same as Point 2	-0.045

[ EYE Mask Vertices at embedded DP Sink Connector Pins ]

Product Specification

3-3-2. eDP AUX Channel Signal



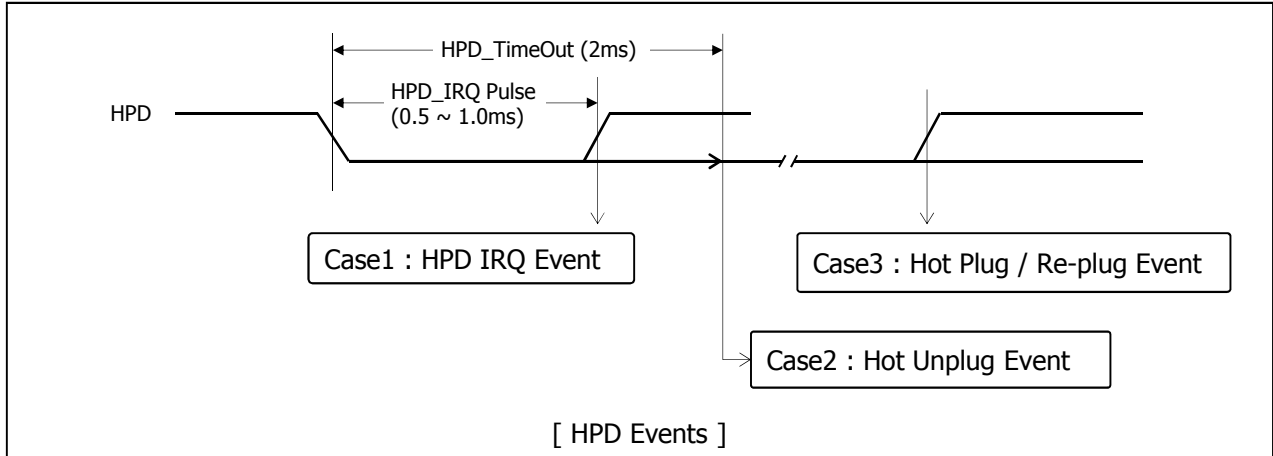
Parameter	Symbol	Min	Typ	Max	Unit	Notes
AUX Unit Interval	UI	0.4	-	0.6	us	
AUX Jitter at Tx IC Package Pins	T <sub>jitter</sub>	-	-	0.04	UI	Equal to 24ns
AUX Jitter at Rx IC Package Pins		-	-	0.05	UI	Equal to 30ns
AUX Peak-to-peak voltage at Connector Pins of Receiving	V <sub>AUX-DIFFp-p</sub>	0.32	-	1.36	V	
AUX Peak-to-peak voltage at Connector Pins of Transmitting		0.39	-	1.38	V	
AUX EYE width at Connector Pins of Tx and Rx		0.98	-	-	UI	
AUX DC common mode voltage	V <sub>AUX-CM_Rx</sub>	-	0	2.0	V	
	V <sub>AUX-CM_Tx</sub>	-	0.15	2.0	V	
AUX AC Coupling Capacitor	C <sub>SOURCE-AUX</sub>	75		200	nF	Source side

Note)

1. Termination resistor is typically integrated into the transmitter and receiver implementations.
2.  $V_{AUX-DIFFp-p} = 2 * |V_{AUXP} - V_{AUXN}|$
3. Termination resistor should be ±50ohm at source side to AUX level.
4. At sink side AUX cap. are for protection ESD/EOS damage.
5. Mismatched common mode voltage will occur abnormal display.

Product Specification

3-3-5. eDP HPD Signal



Parameter	Symbol	Min	Typ	Max	Unit	Notes
HPD Voltage	HPD	2.25	-	3.6	V	Sink side Driving
Hot Plug Detection Threshold		2.0	-	-	V	Source side Detecting
Hot Unplug Detection Threshold		-	-	0.8	V	
HPD_IRQ Pulse Width	HPD_IRQ	0.5	-	1.0	ms	
HPD_TimeOut		2.0	-	-	ms	HPD Unplug Event

Note)

1. HPD IRQ : Sink device wants to notify the Source device that Sink's status has changed so it toggles HPD line, forcing the Source device to read its Link / Sink Receiver DPCD field via the AUX-CH
2. HPD Unplug : The Sink device is no longer attached to the Source device and the Source device may then disable its Main Link as a power saving mode
3. Plug / Re-plug : The Sink device is now attached to the Source device, forcing the Source device to read its Receiver capabilities and Link / Sink status Receiver DPCD fields via the AUX-CH

**Product Specification**
**3-4. Signal Timing Specifications**

This is signal timing required at the input of the TMDS transmitter. All of the interface signal timing should be satisfied with the following specifications for its proper operation.

Table 4. TIMING TABLE

ITEM		SYMBOL	Min	Typ	Max	Unit	Note
DCLK	Period	tCLK	1.875	1.875	1.875	ns	
	Frequency	fCLK	533.25	533.25	533.25	MHz	-
Hsync	Period	tHP	3980	4000	4020	tCLK	
	Width-Active	tWH	32	32	32		
Vsync	Period	tVP	2222	2222	2222	tHP	
	Frequency	fV	59.7	59.997	60.3	Hz	
	Width-Active	tWV	5	5	5	tHP	
Data Enable	Horizontal Valid	tHV	3840	3840	3840	tCLK	
	Horizontal Back Porch	tHBP	60	80	100		
	Horizontal Front Porch	tHFP	48	48	48		
	Horizontal Blank	-	140	160	180		tWH+ tHBP+ tHFP
	Vertical Valid	tVV	2160	2160	2160	tHP	
	Vertical Back Porch	tVBP	54	54	54		
	Vertical Front Porch	tVFP	3	3	3		
	Vertical Blank	-	62	62	62		tWV+ tVBP+ tVFP

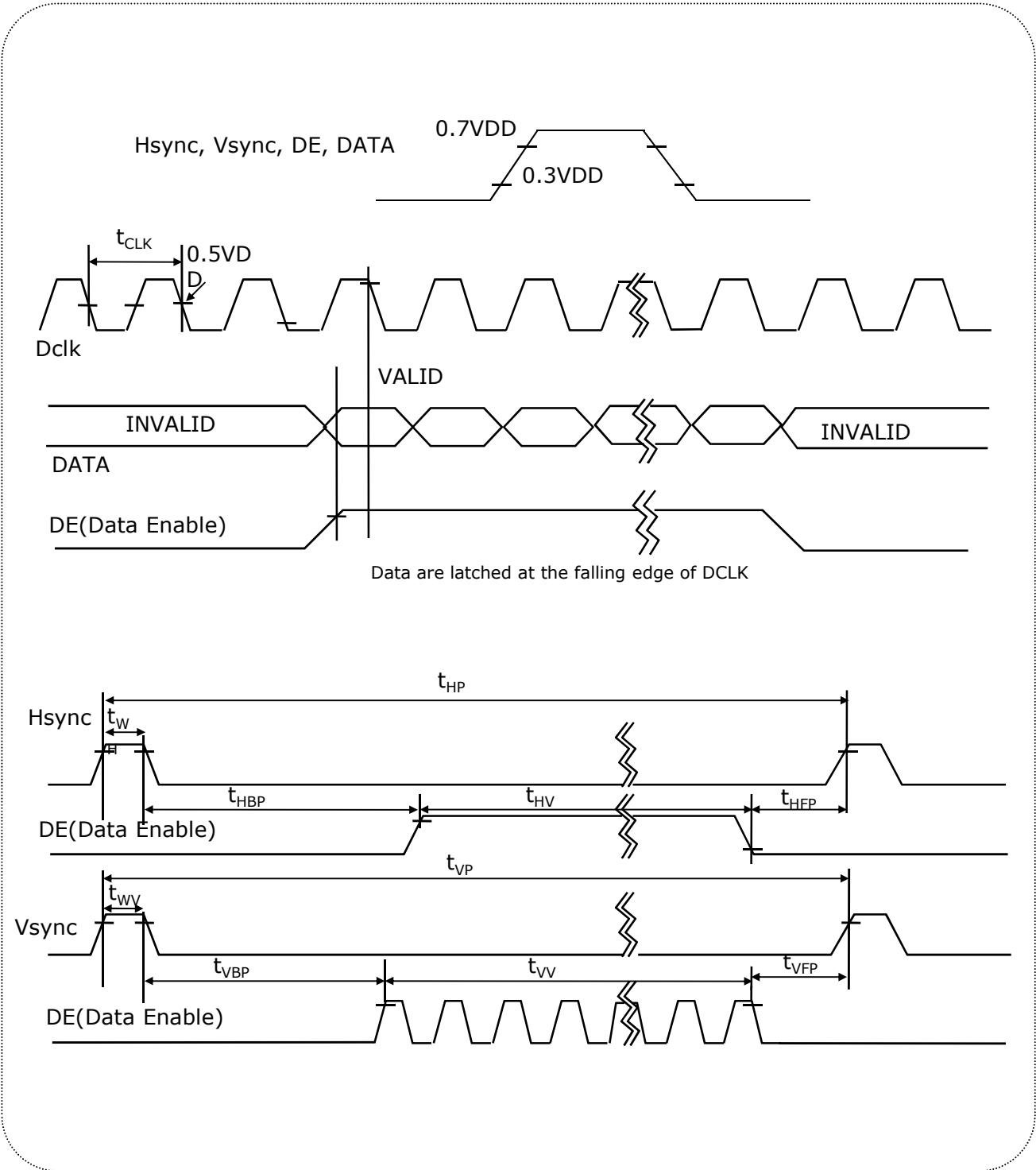
**Note:**

1. DE Only mode operation. The input of Hsync & Vsync signal does not have an effect on LCD normal operation.
2. The performance of the electro-optical characteristics may be influenced by variance of the vertical refresh rates.
3. Horizontal period should be even.



Product Specification

3-5. Signal Timing Waveforms



**Product Specification**

### 3-6. Color Input Data Reference

The Brightness of each primary color(red,green,blue) is based on the 10-bit gray scale data input for the color; the higher the binary input, the brighter the color. The table below provides a reference for color versus data input.

**Table 5. COLOR DATA REFERENCE**

Color		Input Color Data																														
		RED										GREEN										BLUE										
		MSB	LSB								MSB	LSB								MSB	LSB											
		R9	R8	R7	R6	R5	R4	R3	R2	R1	R0	G9	G8	G7	G6	G5	G4	G3	G2	G1	G0	B9	B8	B7	B6	B5	B4	B3	B2	B1	B0	
Basic Color	Black	0	0	0	0	0	0	0	0	0	0	0	0	0	0	0	0	0	0	0	0	0	0	0	0	0	0	0	0	0	0	0
	Red (1023)	1	1	1	1	1	1	1	1	1	1	0	0	0	0	0	0	0	0	0	0	0	0	0	0	0	0	0	0	0	0	0
	Green (1023)	0	0	0	0	0	0	0	0	0	0	1	1	1	1	1	1	1	1	1	1	1	0	0	0	0	0	0	0	0	0	0
	Blue (1023)	0	0	0	0	0	0	0	0	0	0	0	0	0	0	0	0	0	0	0	0	0	1	1	1	1	1	1	1	1	1	1
	Cyan	0	0	0	0	0	0	0	0	0	0	1	1	1	1	1	1	1	1	1	1	1	1	1	1	1	1	1	1	1	1	1
	Magenta	1	1	1	1	1	1	1	1	1	1	0	0	0	0	0	0	0	0	0	0	0	1	1	1	1	1	1	1	1	1	1
	Yellow	1	1	1	1	1	1	1	1	1	1	1	1	1	1	1	1	1	1	1	1	1	0	0	0	0	0	0	0	0	0	0
	White	1	1	1	1	1	1	1	1	1	1	1	1	1	1	1	1	1	1	1	1	1	1	1	1	1	1	1	1	1	1	1
RED	RED (000)	0	0	0	0	0	0	0	0	0	0	0	0	0	0	0	0	0	0	0	0	0	0	0	0	0	0	0	0	0	0	
	RED (001)	0	0	0	0	0	0	0	0	0	0	0	0	0	0	0	0	0	0	0	0	0	0	0	0	0	0	0	0	0	0	
	...	...										...										...										
	RED (1022)	1	1	1	1	1	1	1	1	1	0	0	0	0	0	0	0	0	0	0	0	0	0	0	0	0	0	0	0	0	0	0
	RED (1023)	1	1	1	1	1	1	1	1	1	1	0	0	0	0	0	0	0	0	0	0	0	0	0	0	0	0	0	0	0	0	0
GREEN	GREEN (000)	0	0	0	0	0	0	0	0	0	0	0	0	0	0	0	0	0	0	0	0	0	0	0	0	0	0	0	0	0	0	
	GREEN (001)	0	0	0	0	0	0	0	0	0	0	0	0	0	0	0	0	0	0	0	0	0	0	0	0	0	0	0	0	0	0	
	...	...										...										...										
	GREEN (1022)	0	0	0	0	0	0	0	0	0	0	1	1	1	1	1	1	1	1	1	0	0	0	0	0	0	0	0	0	0	0	
	GREEN (1023)	0	0	0	0	0	0	0	0	0	0	1	1	1	1	1	1	1	1	1	1	0	0	0	0	0	0	0	0	0	0	
BLUE	BLUE (000)	0	0	0	0	0	0	0	0	0	0	0	0	0	0	0	0	0	0	0	0	0	0	0	0	0	0	0	0	0	0	
	BLUE (001)	0	0	0	0	0	0	0	0	0	0	0	0	0	0	0	0	0	0	0	0	0	0	0	0	0	0	0	0	0	1	
	...	...										...										...										
	BLUE (1022)	0	0	0	0	0	0	0	0	0	0	0	0	0	0	0	0	0	0	0	0	1	1	1	1	1	1	1	1	0	0	
	BLUE (1023)	0	0	0	0	0	0	0	0	0	0	0	0	0	0	0	0	0	0	0	0	1	1	1	1	1	1	1	1	1	1	

Product Specification

3-7. Power Sequence

3-7-1. Power Sequence

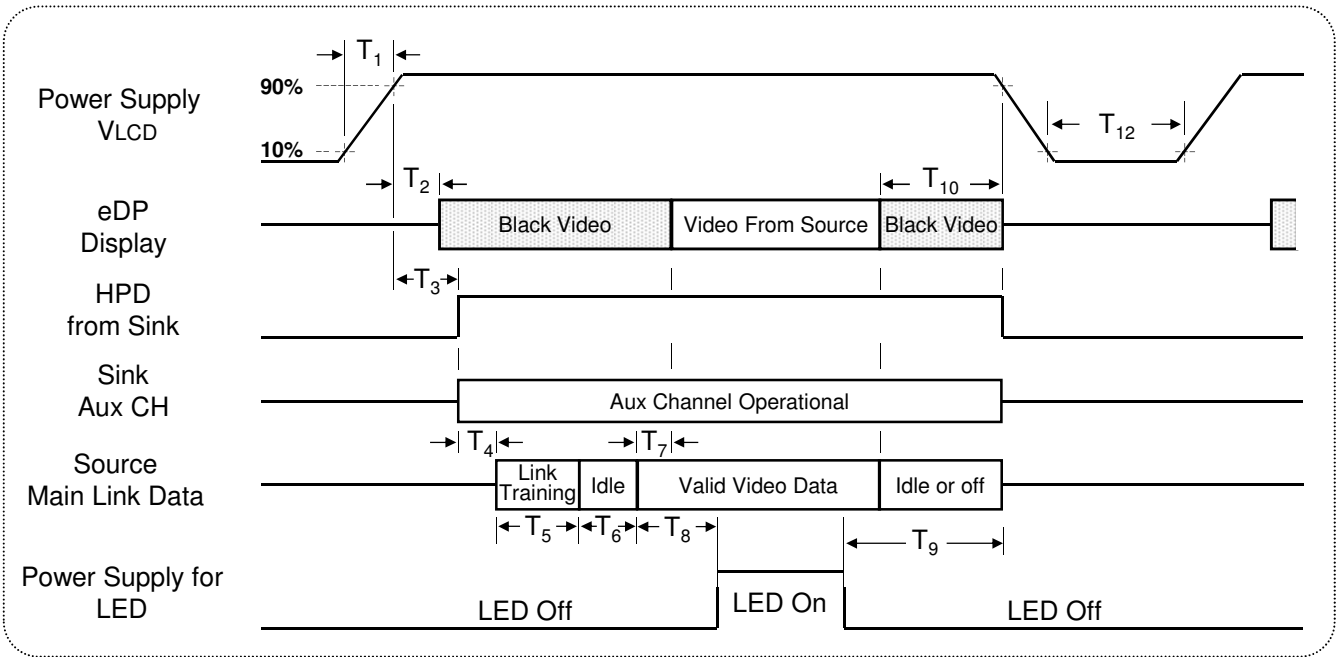


Table 6. POWER SEQUENCE TABLE

Timing	Required By	Limits		Units	Notes
		Min	Max		
T <sub>1</sub>	Source	0.5	10	ms	-
T <sub>2</sub>	Sink	10	200	ms	-
T <sub>3</sub>	Sink	15	200	ms	-
T <sub>4</sub>	Source	-	-	ms	6
T <sub>5</sub>	Source	-	-	ms	6
T <sub>6</sub>	Source	-	100	ms	-
T <sub>7</sub>	Sink	0	50	ms	-
T <sub>8</sub>	Source	200	-	ms	
T <sub>9</sub>	Source	200	-	ms	7

Timing	Required By	Limits		Units	Notes
		Min	Max		
T <sub>10</sub>	Source	0	500	ms	-
T <sub>12</sub>	Source	1000	-	ms	

- Note)
- Do not insert the mating cable when system turn on.
  - Valid Data have to meet "3-3. Signal Timing Specifications"
  - When the Video signal is invalid, be sure to pull down the power supply for LCD VLCD to 0V.
  - The above power sequence should be satisfied the basic power on/off and resolution, timing transition.
  - LED power must be turn on after power supply for LCD and valid status of Video Signal.
  - Link training duration is dependent on the customer's system.
  - LED power must be turned off while Video data signal is valid

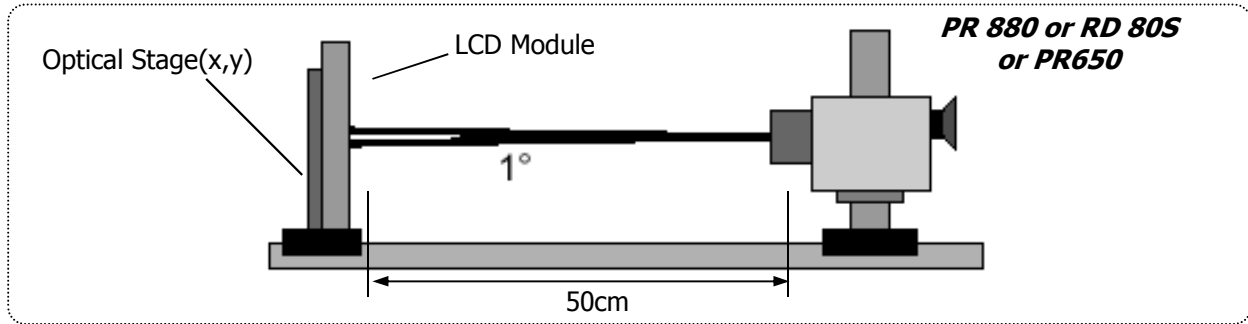


**Product Specification**

### 4. Optical Specifications

Optical characteristics are determined after the unit has been 'ON' for approximately 30 minutes in a dark environment at  $25 \pm 2^\circ\text{C}$ . The values specified are at an approximate distance 50cm from the LCD surface at a viewing angle of  $\Phi$  and  $\theta$  equal to  $0^\circ$  and aperture 1 degree.

FIG. 6 presents additional information concerning the measurement equipment and method.



**FIG.7 Optical Characteristic Measurement Equipment and Method**

**Table 7. OPTICAL CHARACTERISTICS** ( $T_a=25^\circ\text{C}$ ,  $V_{LCD}=10\text{V}$ ,  $f_v=60\text{Hz}$  Dclk=533.25 MHz,  $I_s=130\text{ mA}$ )

Parameter	Symbol	Values			Units	Notes	
		Min	Typ	Max			
Contrast Ratio	CR	910	1300	-		1	
Surface Luminance, white	$L_{WH}$	280	350	-	cd/m <sup>2</sup>	2	
Luminance Variation	$\delta_{WHITE}$	75	-	-	%	3	
Response Time	Gray To Gray	$T_{GTG\_AVR}$	-	14	25	ms	4
Color Coordinates [CIE1931] <i>(By PR650)</i>	RED	Rx	Typ -0.03	TBD	Typ +0.03		
		Ry		TBD			
	GREEN	Gx		TBD			
		Gy		TBD			
	BLUE	Bx		TBD			
		By		TBD			
	WHITE	Wx		0.313			
	Wy	0.329					
Color Shift	Horizontal	$\theta_{CST\_H}$	-	178	-	Degree	5
	Vertical	$\theta_{CST\_V}$	-	178	-		
Viewing Angle (CR>10)							
General	Horizontal	$\theta_H$	170	178	-	Degree	6
	Vertical	$\theta_V$	170	178	-		
Gray Scale		-		2.2			7

Product Specification

Notes 1. Contrast Ratio(CR) is defined mathematically as : **(By PR880)**

$$\text{Contrast Ratio} = \frac{\text{Surface Luminance with all white pixels}}{\text{Surface Luminance with all black pixels}}$$

It is measured at center point(Location P1)

2. Surface luminance(L<sub>WH</sub>)is luminance value at Center 1 point(P1) across the LCD surface 50cm from the surface with all pixels displaying white. For more information see FIG.8 (By PR880)

3. The variation in surface luminance , δ WHITE is defined as : **(By PR880)**

$$\delta_{WHITE} = \frac{\text{Minimum}(L_{P1}, L_{P2}, \dots, L_{P9})}{\text{Maximum}(L_{P1}, L_{P2}, \dots, L_{P9})} \times 100$$

Where L1 to L9 are the luminance with all pixels displaying white at 9 locations.  
For more information see FIG.8

4. Gray to gray response time is the time required for the display to transition from gray to gray. For additional information see Table 8. **( By PR880 )**

5. Color shift is the angle at which the average color difference for all Macbeth is lower than 0.02. For more information see FIG.10 **(By EZ Contrast)**

- Color difference (Δu'v')

$$u' = \frac{4x}{-2x + 12y + 3} \quad v' = \frac{9y}{-2x + 12y + 3} \quad \Delta u'v' = \sqrt{(u'_1 - u'_2)^2 + (v'_1 - v'_2)^2}$$

$$\text{Avg}(\Delta u'v') = \frac{\sum_{i=1}^{24} (\Delta u'v')_i}{24}$$

u'1, v'1 : u'v' value at viewing angle direction  
u'2, v'2 : u'v' value at front (θ=0)  
i : Macbeth chart number (Define 23 page)

- Pattern size : 25% Box size

- Viewing angle direction of color shift : Horizontal, Vertical

6. Viewing angle is the angle at which the contrast ratio is greater than 10. The angles are determined for the horizontal or x axis and the vertical or y axis with respect to the z axis which is normal to the LCD surface. For more information see FIG.11 **(By PR880)**

7. Gamma Value is approximately 2.2. For more information see Table 9.

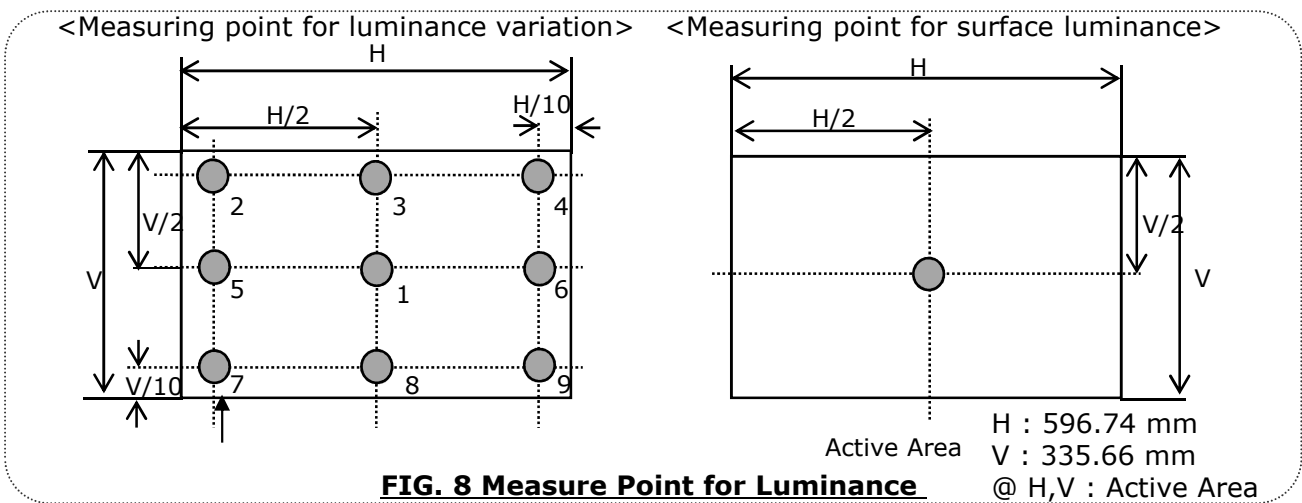
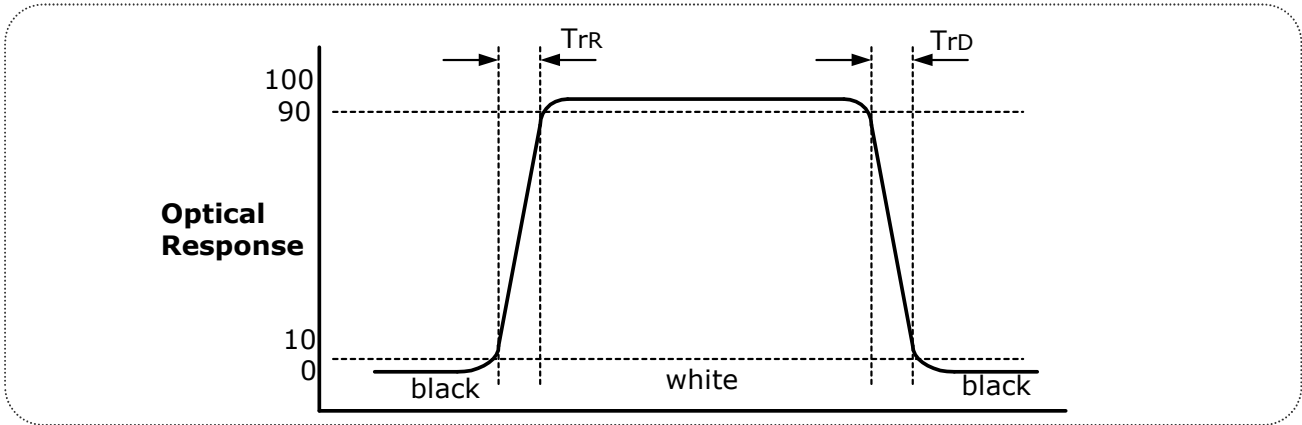


FIG. 8 Measure Point for Luminance

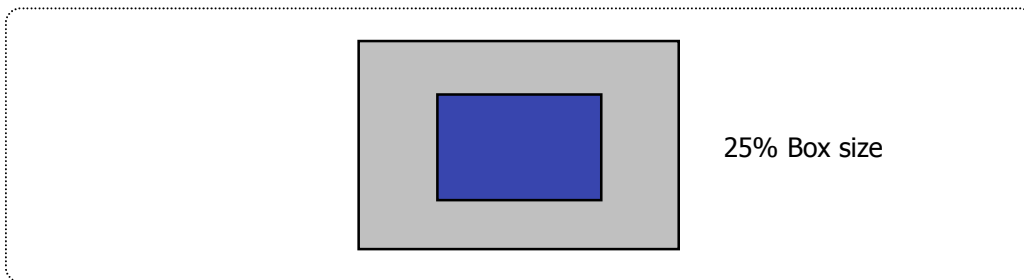
**Product Specification**

The response time is defined as the following figure and shall be measured by switching the input signal for "black" and "white".



**FIG.9 Response time**

Color shift is defined as the following test pattern and color.



**FIG.10 Color Shift Test Pattern**

Average RGB values in Bruce RGB for Macbeth Chart

	Dark skin	Light skin	Blue sky	Foliage	Blue flower	Bluish green
R	395	827	343	311	519	459
G	227	571	451	411	475	799
B	183	495	647	187	743	715
	Orange	Purplish blue	Moderate red	Purple	Yellow green	Orange yellow
R	879	227	847	307	643	923
G	419	279	271	159	775	651
B	99	699	351	347	235	119
	Blue	Green	Red	Yellow	Magenta	cyan
R	107	291	791	967	831	143
G	131	595	111	851	251	507
B	583	263	151	147	607	691
	White	Neutral 8	Neutral 6.5	Neutral 5	Neutral 3.5	black
R	963	827	623	443	255	91
G	963	827	623	443	255	91
B	963	827	623	443	255	91





Product Specification

**Table 8. Gray to gray response time table**

Gray to Gray		Rising Time				
		G1023	G767	G511	G255	G0
Falling Time	G1023					
	G767					
	G511					
	G255					
	G0					

**Table 9. Gray Scale Specification**

Gray Level	Relative Luminance [%] (Typ.)
0	0.10
63	0.30
127	1.08
191	2.50
255	4.71
319	7.70
383	11.52
447	16.18
511	21.72
575	28.15
639	35.51
703	43.81
767	53.07
831	63.30
895	74.52
959	86.75
1023	100

Product Specification

**5. Mechanical Characteristics**

The contents provide general mechanical characteristics. In addition the figures in the next page are detailed mechanical drawing of the LCD.

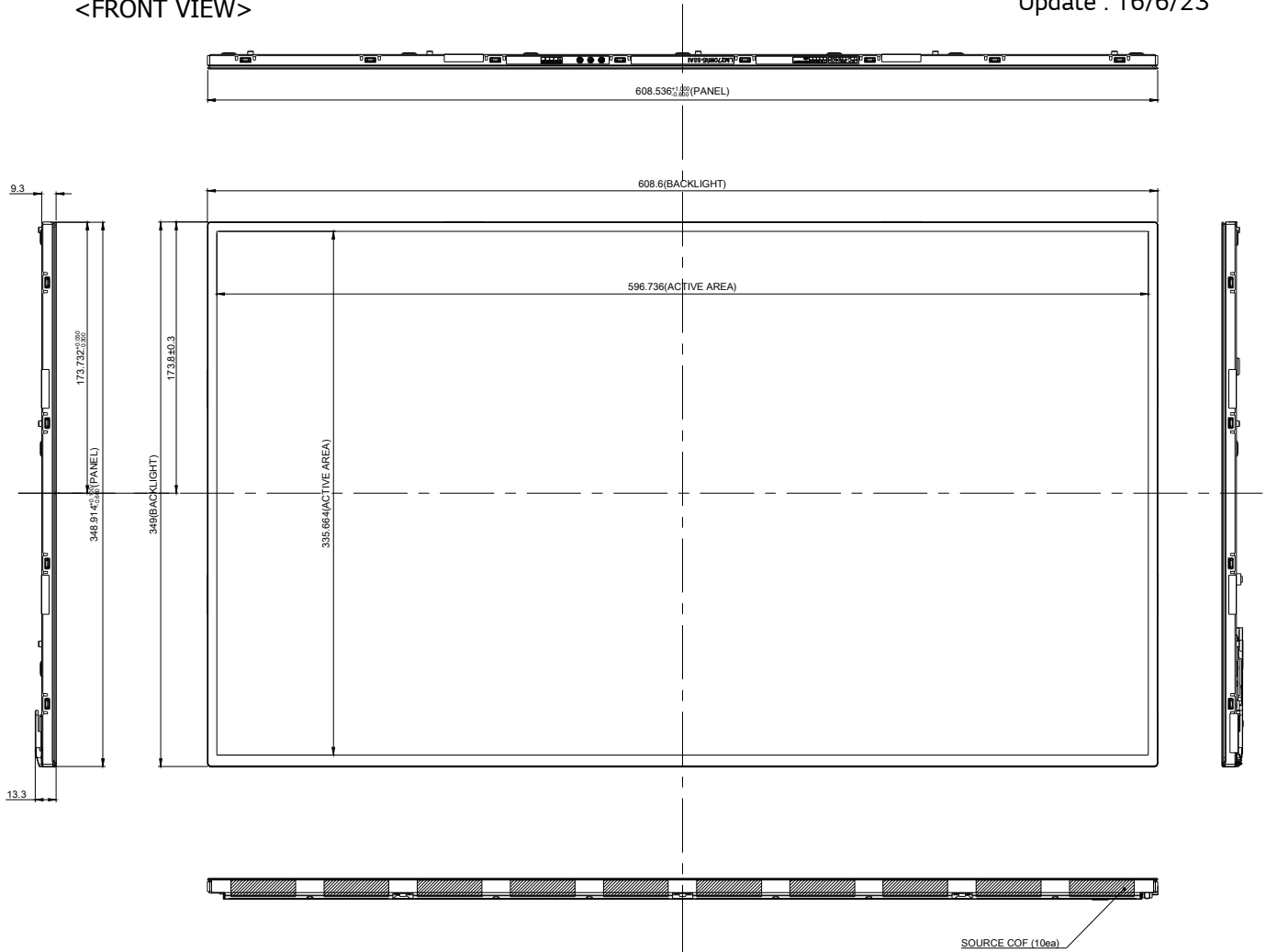
Outline Dimension	Horizontal	608.6mm
	Vertical	349mm
	Depth	13.3mm
Bezel Area	Horizontal	-
	Vertical	-
Active Display Area	Horizontal	596.74mm
	Vertical	335.66mm
Weight	2,266g (Typ.) / 2,379g (Max.)	
Surface Treatment	Advanced Anti-glare treatment of the front polarizer (3H)	

Notes : Please refer to a mechanic drawing in terms of tolerance at the next page.

**Product Specification**

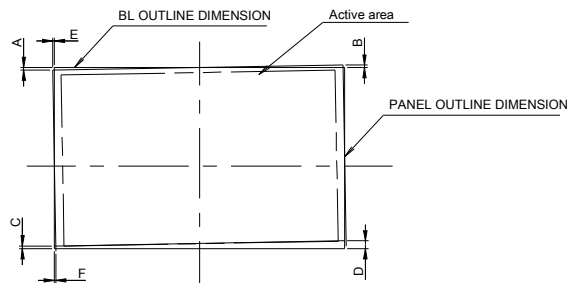
<FRONT VIEW>

Update : 16/6/23



**Notes**

1. I/F connector specification : LSMtron, GT05Q-30S-H10-MN or Equivalent.
2. LED connector specification: SM06B-SHJH (HF) (Manufactured by JST) or Equivalent
3. Torque of user hole: 3.0~4.0kgf-cm.
4. Tilt and partial disposition tolerance of display area as following
  - (1) Y-direction
    - a. Upper side :  $-0.45 < A < 0.45, -0.45 < B < 0.45$
    - b. Lower side :  $-0.45 < C < 0.6, -0.45 < D < 0.6$
  - (2) X-direction :  $-0.45 < E < 0.45, -0.45 < F < 0.45$

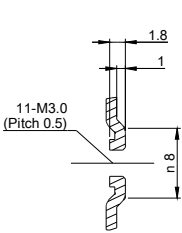
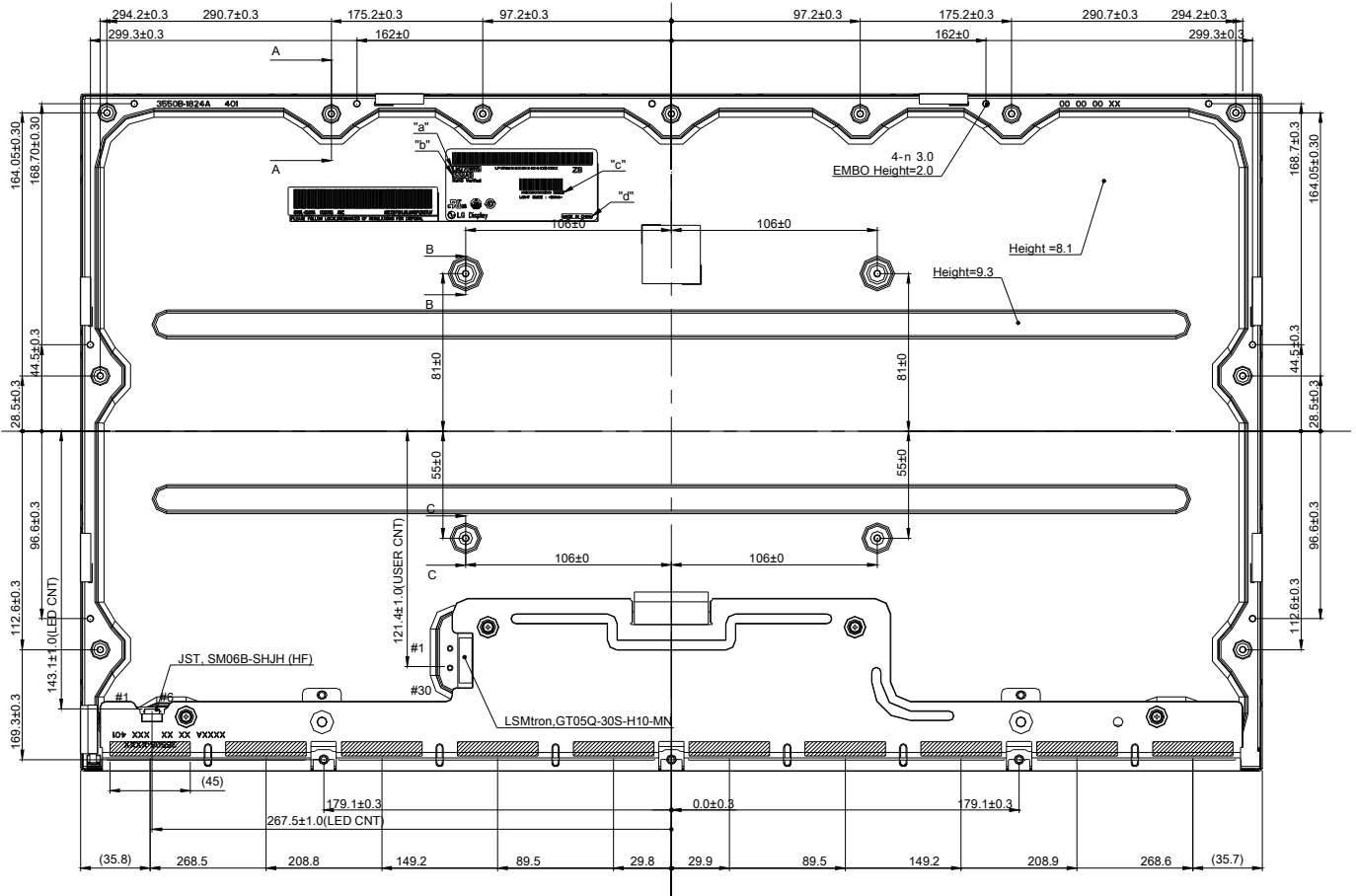


5. Unspecified tolerances to be  $\pm 0.5$
6. The LCM warp(warpage) is less than 1.0 on the surface plate
7. The COF area is weak & sensitive, so please don't press the COF area

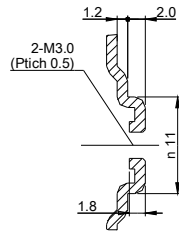
**Product Specification**

<REAR VIEW>

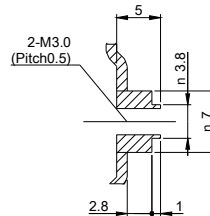
Update : 16/6/23



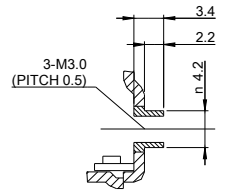
SECTION A-A  
SCALE 2/1



SECTION B-B  
SCALE 2/1



SECTION C-C  
SCALE 2/1



SECTION D-D  
SCALE 2/1

**Product Specification**
**6. Reliability**

Environment test condition

No	Test Item	Condition	Notes
1	High temperature storage test	Ta= 60°C 240h	1
2	Low temperature storage test	Ta= -20°C 240h	1
3	High temperature operation test	Ta= 50°C 50%RH 240h	1
4	Low temperature operation test	Ta= 0°C 240h	1
5	Altitude operating storage / shipment	0 - 16,400 feet(5,000m) 0 - 40,000 feet(12,192m)	

Note 1. Result Evaluation Criteria:

TFT-LCD panels test should take place after cooling enough at room temperature.

In the standard condition, there should be no particular problems that may affect the display function.

 ※. T<sub>a</sub>= Ambient Temperature

## **7. International Standards**

### **7-1. Safety**

- a) UL 60950-1, Underwriters Laboratories Inc.  
Information Technology Equipment - Safety - Part 1 : General Requirements.
- b) CAN/CSA-C22.2 No. 60950-1-07, Canadian Standards Association.  
Information Technology Equipment - Safety - Part 1 : General Requirements.
- c) EN 60950-1, European Committee for Electrotechnical Standardization (CENELEC).  
Information Technology Equipment - Safety - Part 1 : General Requirements.
- d) IEC 60950-1, The International Electrotechnical Commission (IEC).  
Information Technology Equipment - Safety - Part 1 : General Requirements

### **7-2. Environment**

- a) RoHS, Directive 2011/65/EU of the European Parliament and of the council of 8 June 2011

Product Specification

## 8. Packing

### 8-1. Designation of Lot Mark

a) Lot Mark

A	B	C	D	E	F	G	H	I	J	K	L	M
---	---	---	---	---	---	---	---	---	---	---	---	---

A,B,C : SIZE(INCH)  
E : MONTH

D : YEAR  
F ~ M : SERIAL NO.

Note

1. YEAR

Year	2011	2012	2013	2014	2015	2016	2017	2018	2019	2020
Mark	A	B	C	D	E	F	G	H	J	K

2. MONTH

Month	Jan	Feb	Mar	Apr	May	Jun	Jul	Aug	Sep	Oct	Nov	Dec
Mark	1	2	3	4	5	6	7	8	9	A	B	C

b) Location of Lot Mark

Serial No. is printed on the label. The label is attached to the backside of the LCD module.  
This is subject to change without prior notice.

### 8-2. Packing Form

1) Package quantity in one box : 10ea

b) Box Size : 710mm X 365mm X 448mm

**Product Specification****9. PRECAUTIONS**

Please pay attention to the followings when you use this TFT LCD module.

**9-1. MOUNTING PRECAUTIONS**

- (1) You must mount a module using holes arranged in four corners or four sides.
- (2) You should consider the mounting structure so that uneven force (ex. Twisted stress) is not applied to the module. And the case on which a module is mounted should have sufficient strength so that external force is not transmitted directly to the module.
- (3) Please attach the surface transparent protective plate to the surface in order to protect the polarizer. Transparent protective plate should have sufficient strength in order to resist external force.
- (4) You should adopt radiation structure to satisfy the temperature specification.
- (5) Acetic acid type and chlorine type materials for the cover case are not desirable because the former generates corrosive gas of attacking the polarizer at high temperature and the latter causes circuit break by electro-chemical reaction.
- (6) Do not touch, push or rub the exposed polarizers with glass, tweezers or anything harder than HB pencil lead. And please do not rub with dust clothes with chemical treatment. Do not touch the surface of polarizer for bare hand or greasy cloth.(Some cosmetics are detrimental to the polarizer.)
- (7) When the surface becomes dusty, please wipe gently with absorbent cotton or other soft materials like chamois soaks with petroleum benzene. Normal-hexane is recommended for cleaning the adhesives used to attach front / rear polarizers. Do not use acetone, toluene and alcohol because they cause chemical damage to the polarizer.
- (8) Wipe off saliva or water drops as soon as possible. Their long time contact with polarizer causes deformations and color fading.
- (9) Do not open the case because inside circuits do not have sufficient strength.
- (10) As The IPS panel is sensitive & slim, please recommend the metal frame of the system supports the panel by the double side-mount.

**9-2. OPERATING PRECAUTIONS**

- (1) The spike noise causes the mis-operation of circuits. It should be lower than following voltage :  
 $V = \pm 200\text{mV}$ (Over and under shoot voltage)
- (2) Response time depends on the temperature.(In lower temperature, it becomes longer.)
- (3) Brightness depends on the temperature. (In Higher temperature, it becomes lower.)  
And in lower temperature, response time(required time that brightness is stable after turned on) becomes longer.
- (4) Be careful for condensation at sudden temperature change. Condensation makes damage to polarizer or electrical contacted parts. And after fading condensation, smear or spot will occur.
- (5) When fixed patterns are displayed for a long time, remnant image is likely to occur.
- (6) Module has high frequency circuits. Sufficient suppression to the electromagnetic interference shall be done by system manufacturers. Grounding and shielding methods may be important to minimized the interference.
- (7) Please do not give any mechanical and/or acoustical impact to LCM. Otherwise, LCM can't be operated its full characteristics perfectly.
- (8) A screw which is fastened up the steels should be a machine screw.  
(if not, it causes metallic foreign material and deal LCM a fatal blow)
- (9) Please do not set LCD on its edge.
- (10) When LCMs are used for public display defects such as Yogore, image sticking can not be guarantee.
- (11) LCMs cannot support "Interlaced Scan Method"
- (12) Please conduct image sticking test after 2-hour aging with Rolling PTN and normal temperature(25~40°C)
- (13) When this reverse model is used as a forward-type model (PCB on top side), LGD can not guarantee any defects of LCM.



### **9-3. ELECTROSTATIC DISCHARGE CONTROL**

Since a module is composed of electronic circuits, it is not strong to electrostatic discharge. Make certain that treatment persons are connected to ground through wrist band etc. And don't touch interface pin directly.

### **9-4. PRECAUTIONS FOR STRONG LIGHT EXPOSURE**

Strong light exposure causes degradation of polarizer and color filter.

### **9-5. STORAGE**

When storing modules as spares for a long time, the following precautions are necessary.

- (1) Store them in a dark place. Do not expose the module to sunlight or fluorescent light. Keep the temperature between 5°C and 35°C at normal humidity.
- (2) The polarizer surface should not come in contact with any other object.  
It is recommended that they be stored in the container in which they were shipped.

### **9-6. HANDLING PRECAUTIONS FOR PROTECTION FILM**

- (1) The protection film is attached to the bezel with a small masking tape.  
When the protection film is peeled off, static electricity is generated between the film and polarizer.  
This should be peeled off slowly and carefully by people who are electrically grounded and with well ion-blown equipment or in such a condition, etc.
- (2) When the module with protection film attached is stored for a long time, sometimes there remains a very small amount of glue still on the bezel after the protection film is peeled off.
- (3) You can remove the glue easily. When the glue remains on the bezel surface or its vestige is recognized, please wipe them off with absorbent cotton waste or other soft material like chamois soaked with normal-hexane.

## Product Specification

# SPECIFICATION

## FOR

# APPROVAL

Preliminary Specification  
 Final Specification

Title	27.0" UHD TFT LCD
-------	-------------------

BUYER	
MODEL	

SUPPLIER	LG Display Co., Ltd.
*MODEL	LM270WR5
SUFFIX	SSA1

\*When you obtain standard approval, please use the above model name without suffix

APPROVED BY	SIGNATURE DATE
/	
/	
/	

Please return 1 copy for your confirmation with your signature and comments.

APPROVED BY	SIGNATURE DATE
W.G. Kweon / G.Manager	
<b>REVIEWED BY</b>	
J.H. Song / Manager [C]	
W.Y. Noh / Manager [M]	
S.H. Han / Manager [O]	
J.C. Lim / Manager [P]	
<b>PREPARED BY</b>	
Y.K. Jung / Engineer	

**Product Engineering Dept.**  
**LG Display Co., Ltd**

**Product Specification**
Contents

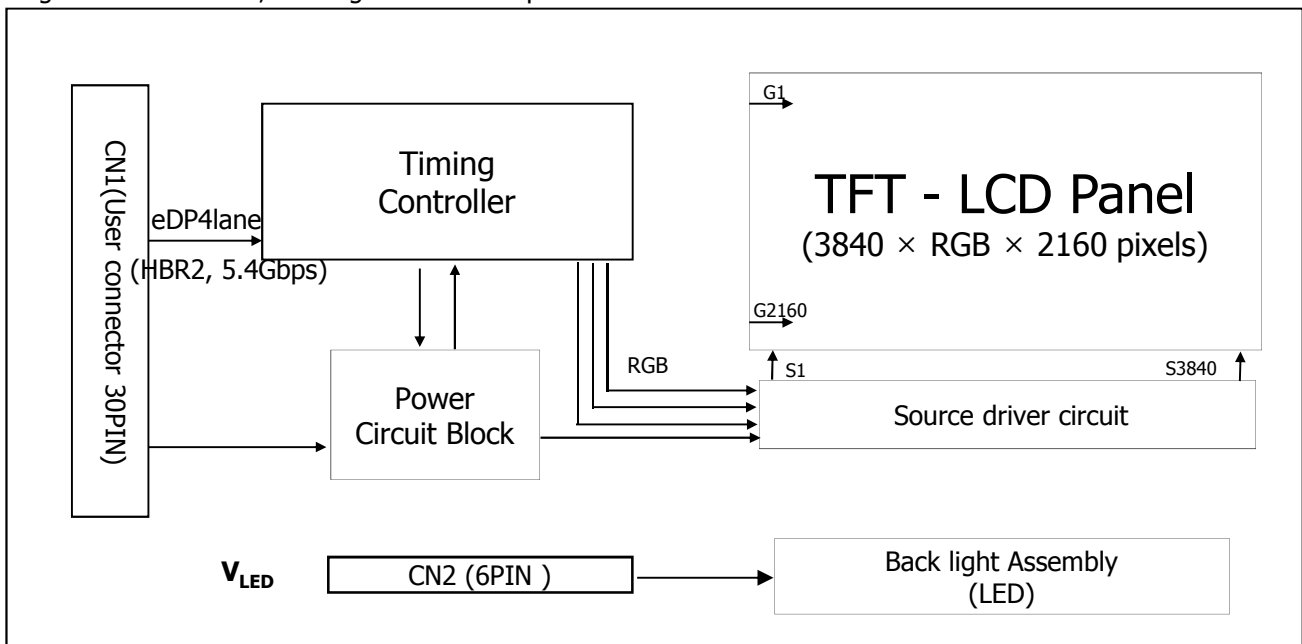
No	ITEM	Page
	COVER	1
	CONTENTS	2
	RECORD OF REVISIONS	3
1	GENERAL DESCRIPTION	4
2	ABSOLUTE MAXIMUM RATINGS	5
3	ELECTRICAL SPECIFICATIONS	6
3-1	ELECTRICAL CHARACTERISTICS	6
3-2	INTERFACE CONNECTIONS	9
3-3	LVDS CHARACTERISTICS	12
3-4	SIGNAL TIMING SPECIFICATIONS	15
3-5	SIGNAL TIMING WAVEFORMS	16
3-6	COLOR INPUT DATA REFERENCE	17
3-7	POWER SEQUENCE & DIP CONDITION FOR LCD MODULE	18
4	OPTICAL SPECIFICATIONS	20
5	MECHANICAL CHARACTERISTICS	25
6	RELIABILITY	28
7	INTERNATIONAL STANDARDS	29
7-1	SAFETY	29
7-2	EMC	29
7-3	ENVIRONMENT	29
8	PACKING	30
8-1	DESIGNATION OF LOT MARK	30
8-2	PACKING FORM	30
9	PRECAUTIONS	31



**Product Specification**

### 1. General Description

LM270WR5 is a Color Active Matrix Liquid Crystal Display with a Light Emitting Diode (LED) backlight system without LED driver. The matrix employs a-Si Thin Film Transistor as the active element. It is a transmissive type display operating in the normally black mode. It has a 27 inch diagonally measured active display area with UHD resolution (3840 horizontal by 2160 vertical pixel array) Each pixel is divided into Red, Green and Blue sub-pixels or dots which are arranged in vertical stripes. Gray scale or the brightness of the sub-pixel color is determined with a 10-bit gray scale signal for each dot, thus, presenting a palette of more than 1.07Billion colors with A-FRC (Advanced Frame Rate Control). It has been designed to apply eDP(HBR2, 5.4Gbps) interface. It is intended to support displays where high brightness, super wide viewing angle, high color saturation, and high color are important.



[ FIG.1 ] Block diagram

### General Features

Active Screen Size	27 inches(68.47cm) diagonal
Outline Dimension	608.6(H) x 349(V) x 13.3(D) mm (Typ.)
Pixel Pitch	0.1554 mm x 0.1554 mm
Pixel Format	3840 horiz. By 2160 vert. Pixels RGB stripes arrangement
Color Depth	1.07 Billion colors, 10Bit (8Bit + A-FRC)
Luminance, White	350 cd/m <sup>2</sup> ( Center 1 Point, Typ.)
Viewing Angle(CR>10)	View Angle Free (R/L 178(Typ.), U/D 178(Typ.))
Power Consumption	Total 31.8 Watt (Typ.) (6.6 Watt @V <sub>LCD</sub> , 25.2 Watt @I <sub>s</sub> = 130 mA)
Weight	2,266g (Typ.) / 2,379g (Max.)
Display Operating Mode	Transmissive mode, normally black
Surface Treatment	Advanced Anti-glare treatment of the front polarizer (3H)

Product Specification

**2. Absolute Maximum Ratings**

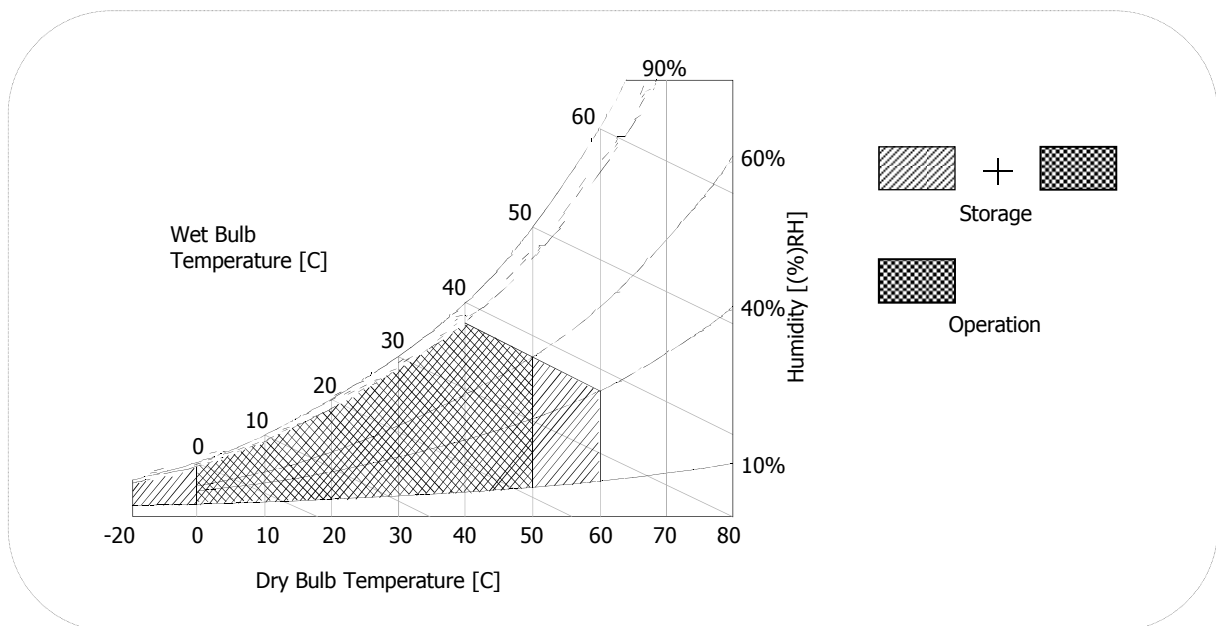
The following are maximum values which, if exceeded, may cause faulty operation or damage to the unit.

**Table 1. ABSOLUTE MAXIMUM RATINGS**

Parameter	Symbol	Values		Units	Notes
		Min	Max		
Power Input Voltage	V <sub>LCD</sub>	-0.3	12	V <sub>dc</sub>	at 25 ± 2°C
Operating Temperature	T <sub>OP</sub>	0	50	°C	1, 2, 3
Storage Temperature	T <sub>ST</sub>	-20	60	°C	
Operating Ambient Humidity	H <sub>OP</sub>	10	90	%RH	
Storage Humidity	H <sub>ST</sub>	10	90	%RH	
LCM Surface Temperature (Operation)	T <sub>Surface</sub>	0	65	°C	1,4

- Note : 1. Temperature and relative humidity range are shown in the figure below.  
 Wet bulb temperature should be 39 °C Max, and no condensation of water.  
 2. Maximum Storage Humidity is up to 40°C, 70% RH only for 4 corner light leakage Mura.  
 3. Storage condition is guaranteed under packing condition  
 4. LCM Surface Temperature should be Min. 0°C and Max. 65°C under the V<sub>LCD</sub>=10.0V, f<sub>V</sub>=60Hz, 25°C ambient Temp. no humidity control and LED string current is typical value.

**FIG.2 Temperature and relative humidity**



**Product Specification**
**3. Electrical Specifications**
**3-1. Electrical Characteristics**

It requires two power inputs. One is employed to power the LCD electronics and to drive the TFT array and liquid crystal. The second input power for the LED/Backlight, is typically generated by a LED Driver. The LED Driver is an external unit to the LCDs.

**Table 2-1. ELECTRICAL CHARACTERISTICS**

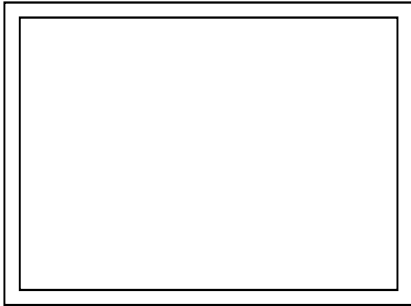
Parameter	Symbol	Values			Unit	Notes
		Min	Typ	Max		
MODULE :						
Power Supply Input Voltage	V <sub>LCD</sub>	9.5	10.0	10.5	Vdc	5
Permissive Power Input Ripple	V <sub>dRF</sub>			400	mV <sub>p-p</sub>	1
Power Supply Input Current	I <sub>LCD</sub>	-	660	825	mA	2
		-	920	1150	mA	3
Power Consumption	P <sub>c</sub> TYP	-	6.6	8.25	Watt	2
	P <sub>c</sub> MAX	-	9.2	11.5	Watt	3
Rush current	I <sub>RUSH</sub>	-		3	A	4

Note :

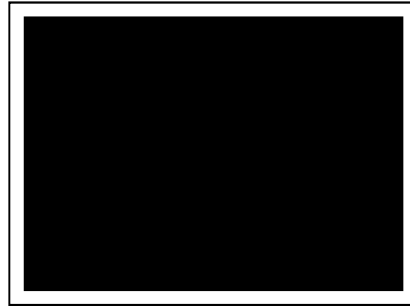
1. Permissive power ripple should be measured under V<sub>LCD</sub>=10.0V, 25 ± 2°C, f<sub>V</sub>=60Hz condition and at that time, we recommend the bandwidth configuration of oscilloscope is to be under 20Mhz.
2. The specified current and power consumption are under the V<sub>LCD</sub>=10.0V, 25 ± 2°C, f<sub>V</sub>=60Hz condition whereas mosaic pattern(8 x 6) is displayed and f<sub>V</sub> is the frame frequency.
3. The current is specified at the maximum current pattern.
4. The duration of rush current is about 2ms and rising time of power Input is 1ms(min.).
5. V<sub>LCD</sub> level must be measured at two points on LCM PCB - between V<sub>LCD</sub>(test point) and LCM Ground. The measured results need to meet the Power supply input voltage spec.  
(Test condition : maximum power pattern , 25± 2°C, f<sub>V</sub>=60Hz)

Product Specification

- **Permissive Power input ripple** ( $V_{LCD} = 10.0V$ ,  $25^{\circ}C$ ,  $f_v$  (frame frequency)=Max. condition)

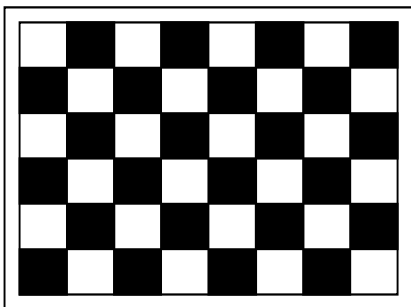


White pattern

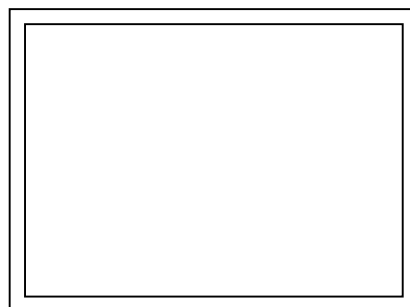


Black pattern

- **Power consumption** ( $V_{LCD} = 10V$ ,  $25^{\circ}C$ ,  $f_v$  (frame frequency)=60Hz condition)



Typical power Pattern



Maximum power Pattern

**FIG.3 Mosaic pattern & White Pattern for power consumption measurement**





Product Specification

**3-2. Interface Connections**

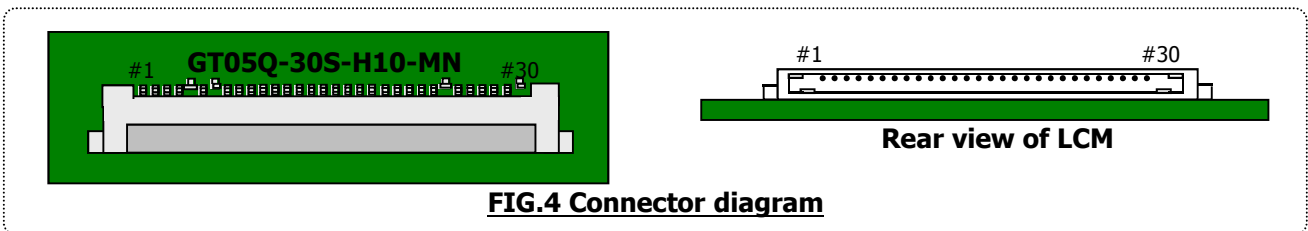
**3-2-1. LCD Module**

- LCD Connector(CN1) : GT05Q-30S-H10-MN (LSMtron), HD2S030HA1 (JAE), KN38B-30S-0.5H(HIROSE) or Equivalent
- Mating Connector : 20453-030T-## (Manufactured by I-PEX) or Equivalent

**Table 3. MODULE CONNECTOR(CN1) PIN CONFIGURATION**

No	Symbol	Description	No	Symbol	Description
1	VLCD	Power Supply +10.0V	16	Lane0P	True Signal for Main Link 0
2	VLCD	Power Supply +10.0V	17	Lane0N	Component Signal for Main Link 0
3	VLCD	Power Supply +10.0V	18	GND	Ground
4	VLCD	Power Supply +10.0V	19	Lane1P	True Signal for Main Link 1
5	VLCD	Power Supply +10.0V	20	Lane1N	Component Signal for Main Link 1
6	NC	No connection	21	GND	Ground
7	GND	Ground	22	Lane2P	True Signal for Main Link 2
8	NC	No Connection	23	Lane2N	Component Signal for Main Link 2
9	NC	No Connection	24	GND	Ground
10	GND	Ground	25	Lane3P	True Signal for Main Link 3
11	HPD	Hot Plug Detect Signal	26	Lane3N	Component Signal for Main Link 3
12	GND	Ground	27	GND	Ground
13	AUX_CHN	Component Signal for Auxiliary Channel	28	GND	Ground
14	AUX_CHP	True Signal for Auxiliary Channel	29	NC	No Connection
15	GND	Ground	30	GND	Ground

- Note: 1. All GND(ground) pins should be connected together and to Vss which should also be connected to the LCD's metal frame.  
 2. All VLCD (power input) pins should be connected together.



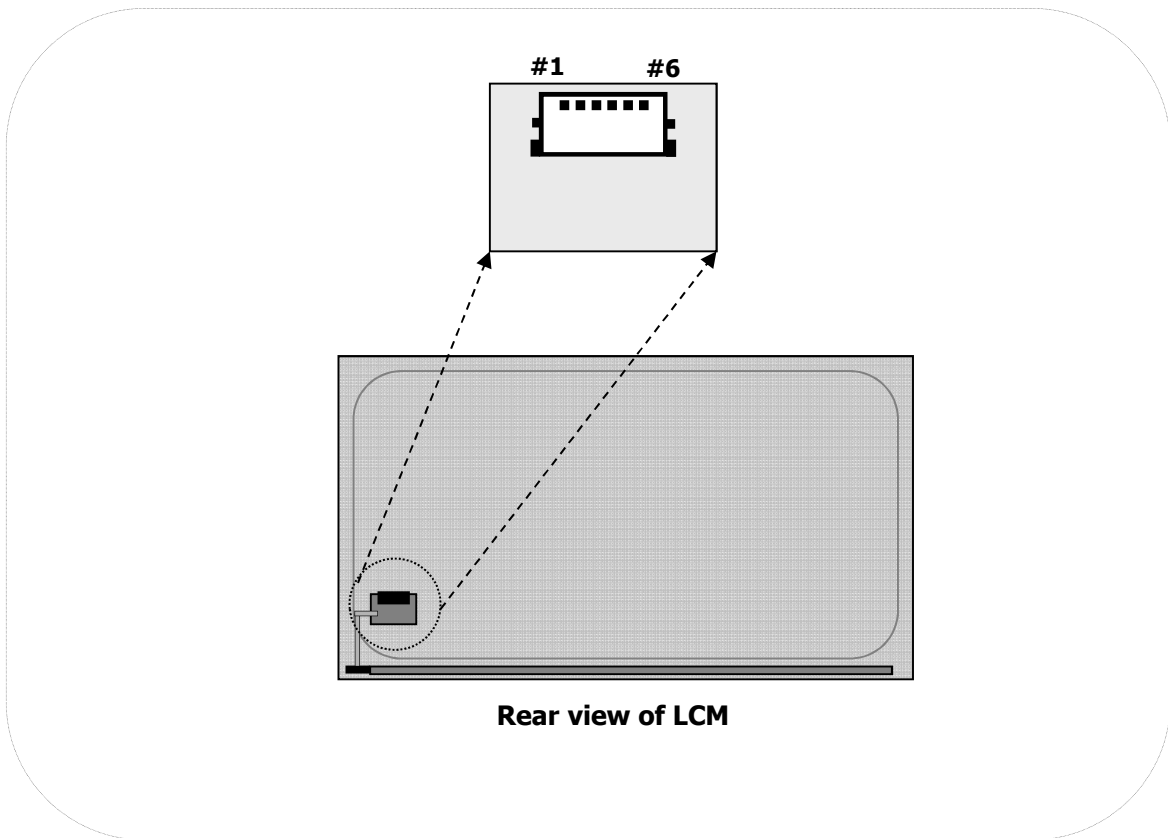
Product Specification

**3-2-2. BACKLIGHT CONNECTOR PIN CONFIGURATION(CN2)**

The LED interface connector is a model SM06B-SHJH(HF)\_Manufactured by JST or equivalent.  
 The mating connector is a SHJP-06V-S(HF), SHJP-06V-A-K(HF) or equivalent.  
 The pin configuration for the connector is shown in the table below.

**Table 3-1. LED CONNECTOR PIN CONFIGURATION**

Pin	Symbol	Description
1	FB1	Channel1 Current Feedback
2	FB2	Channel2 Current Feedback
3	VLED	LED Power Supply
4	VLED	LED Power Supply
5	FB3	Channel3 Current Feedback
6	FB4	Channel4 Current Feedback

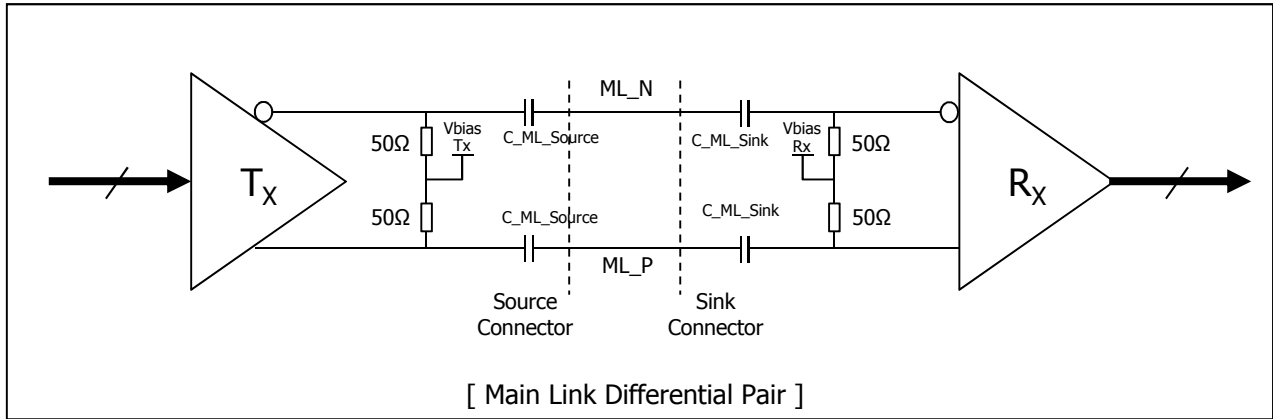


**[ FIG. 5 ] Backlight connector view**

Product Specification

3-3. eDP Signal Specifications

3-3-1. eDP Main Link Signal



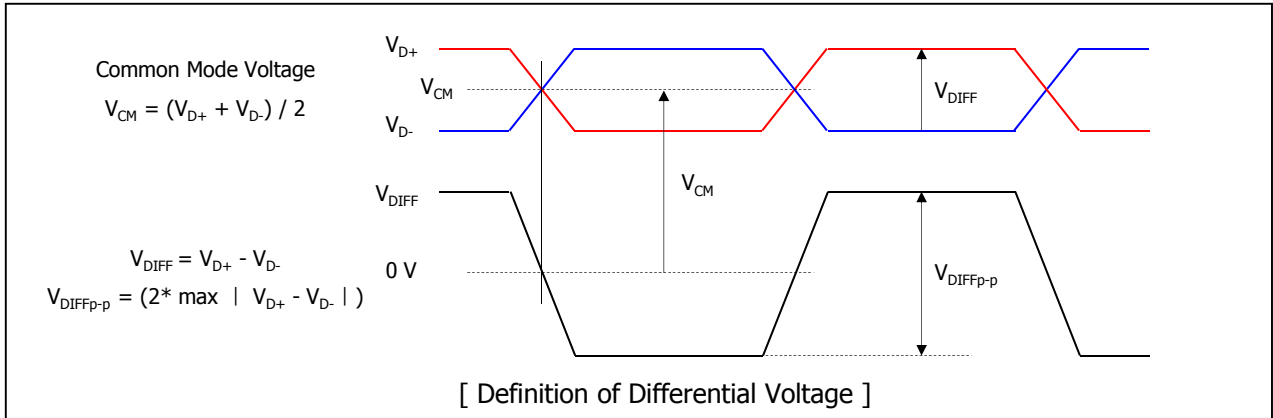
Parameter	Symbol	Min	Typ	Max	Unit	Notes
Unit Interval for high bit rate (5.4Gbps / lane)	UI_HBR2	-	185	-	ps	
Link Clock Down Spreading	Amplitude	0	-	0.5	%	
	Frequency	30		33	kHz	
Differential peak-to-peak voltage at Sink side connector	$V_{RX-DIFFP-P}$	-	-	1.38	V	Note 6,7)
EYE width at Sink side connector	$T_{RX-EYE-CONN}$	0.38	-	-	UI	Note 6,7)
Lane-to-Lane skew	$L_{RX-SKEW-INTER\_PAIR}$	-	-	4UI+ 500ps		
Lane intra-pair skew	$L_{RX-SKEW-INTRA\_PAIR}$	-	-	50	ps	
AC Coupling Capacitor	$C_{SOURCE-ML}$	75		200	nF	Source side

Note)

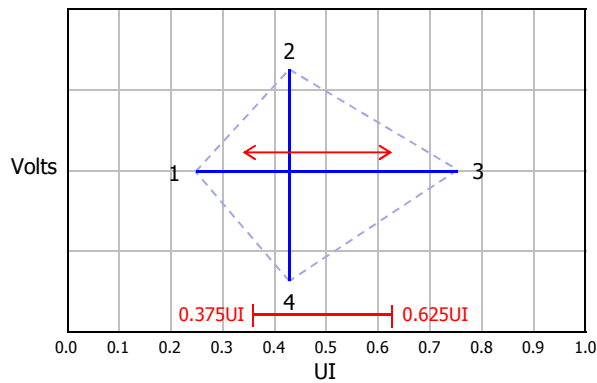
1. Termination resistor is typically integrated into the transmitter and receiver implementations.
2. In cabled embedded system, it is recommended the system designer ensure that EYE width and voltage are met at the sink side connector pins.
3. Mismatched common mode voltage will occur abnormal display.
4. All eDP electrical spec is measured at sink connector side.
5. eDP cable Impedance should be 100ohm ± 5%.

**Product Specification**

**Note6) Definition of Differential Voltage**



**Note7) Main Link EYE Diagram**

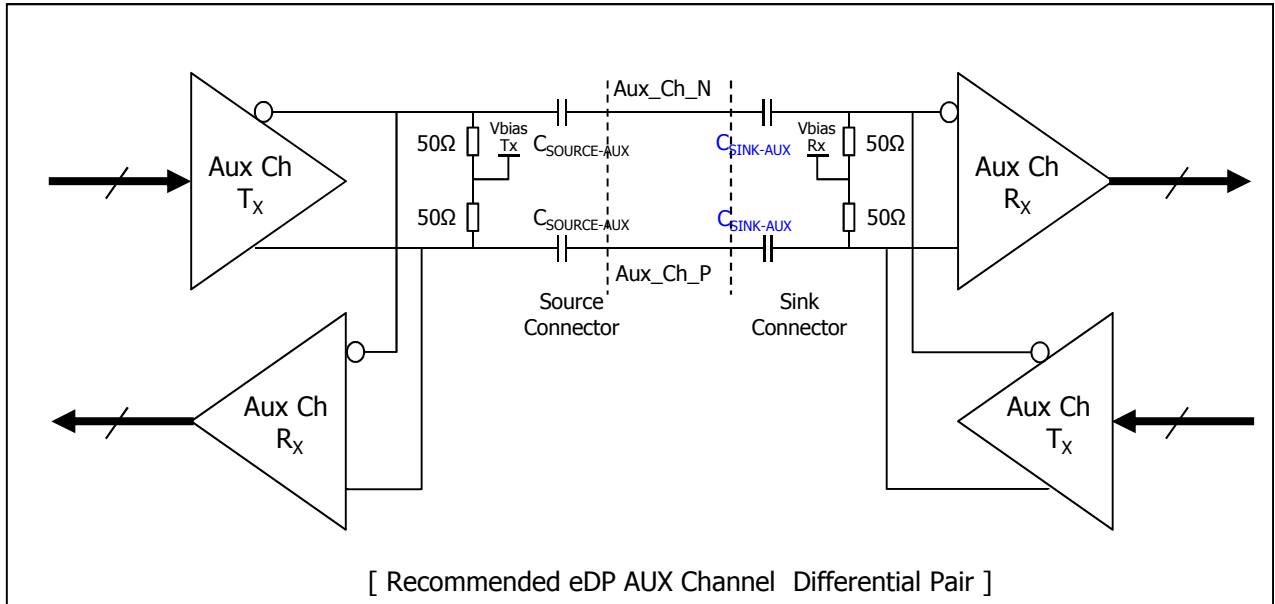


Point	High Bit Rate 2 @ TP3 EQ	
	Time(UI)	Voltage(V)
1	Any UI location (x) where the eye width is open from x to x+0.38UI	0.000
2	Any passing UI location between 0.375UI-0.625UI	0.045
3	Point 1 + 0.38UI	0.000
4	Same as Point 2	-0.045

[ EYE Mask Vertices at embedded DP Sink Connector Pins ]

Product Specification

3-3-2. eDP AUX Channel Signal



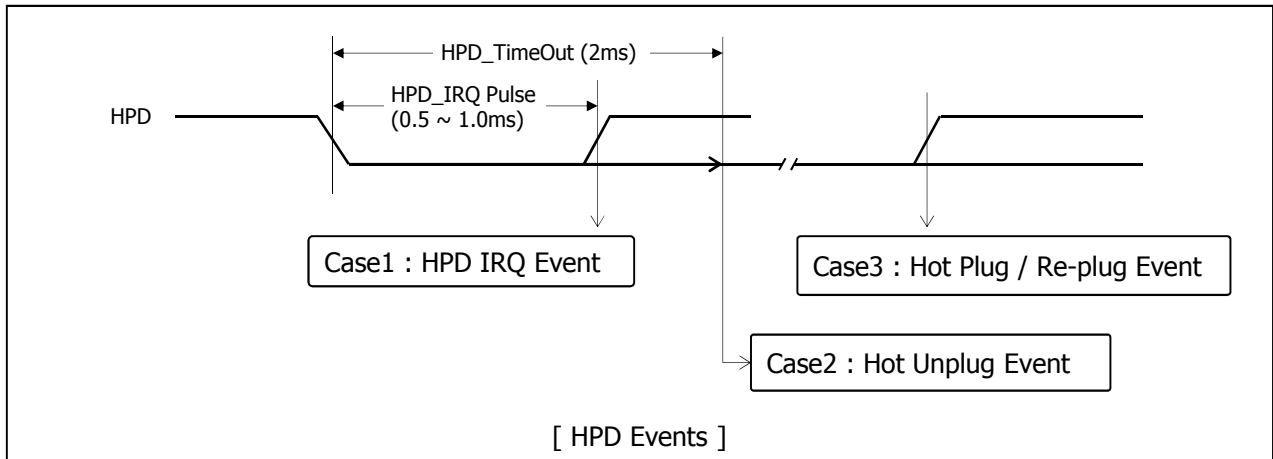
Parameter	Symbol	Min	Typ	Max	Unit	Notes
AUX Unit Interval	UI	0.4	-	0.6	us	
AUX Jitter at Tx IC Package Pins	T <sub>jitter</sub>	-	-	0.04	UI	Equal to 24ns
AUX Jitter at Rx IC Package Pins		-	-	0.05	UI	Equal to 30ns
AUX Peak-to-peak voltage at Connector Pins of Receiving	V <sub>AUX-DIFFp-p</sub>	0.32	-	1.36	V	
AUX Peak-to-peak voltage at Connector Pins of Transmitting		0.39	-	1.38	V	
AUX EYE width at Connector Pins of Tx and Rx		0.98	-	-	UI	
AUX DC common mode voltage	V <sub>AUX-CM_Rx</sub>	-	0	2.0	V	
	V <sub>AUX-CM_Tx</sub>	-	0.15	2.0	V	
AUX AC Coupling Capacitor	C <sub>SOURCE-AUX</sub>	75		200	nF	Source side

Note)

1. Termination resistor is typically integrated into the transmitter and receiver implementations.
2.  $V_{AUX-DIFFp-p} = 2 * |V_{AUXP} - V_{AUXN}|$
3. Termination resistor should be ±50ohm at source side to AUX level.
4. At sink side AUX cap. are for protection ESD/EOS damage.
5. Mismatched common mode voltage will occur abnormal display.

Product Specification

3-3-5. eDP HPD Signal



Parameter	Symbol	Min	Typ	Max	Unit	Notes
HPD Voltage	HPD	2.25	-	3.6	V	Sink side Driving
Hot Plug Detection Threshold		2.0	-	-	V	Source side Detecting
Hot Unplug Detection Threshold		-	-	0.8	V	
HPD_IRQ Pulse Width	HPD_IRQ	0.5	-	1.0	ms	
HPD_TimeOut		2.0	-	-	ms	HPD Unplug Event

Note)

1. HPD IRQ : Sink device wants to notify the Source device that Sink's status has changed so it toggles HPD line, forcing the Source device to read its Link / Sink Receiver DPCD field via the AUX-CH
2. HPD Unplug : The Sink device is no longer attached to the Source device and the Source device may then disable its Main Link as a power saving mode
3. Plug / Re-plug : The Sink device is now attached to the Source device, forcing the Source device to read its Receiver capabilities and Link / Sink status Receiver DPCD fields via the AUX-CH

**Product Specification**
**3-4. Signal Timing Specifications**

This is signal timing required at the input of the TMDS transmitter. All of the interface signal timing should be satisfied with the following specifications for its proper operation.

Table 4. TIMING TABLE

ITEM		SYMBOL	Min	Typ	Max	Unit	Note
DCLK	Period	tCLK	1.875	1.875	1.875	ns	
	Frequency	fCLK	533.25	533.25	533.25	MHz	-
Hsync	Period	tHP	3980	4000	4020	tCLK	
	Width-Active	tWH	32	32	32		
Vsync	Period	tVP	2222	2222	2222	tHP	
	Frequency	fV	59.7	59.997	60.3	Hz	
	Width-Active	tWV	5	5	5	tHP	
Data Enable	Horizontal Valid	tHV	3840	3840	3840	tCLK	
	Horizontal Back Porch	tHBP	60	80	100		
	Horizontal Front Porch	tHFP	48	48	48		
	Horizontal Blank	-	140	160	180		tWH+ tHBP+ tHFP
	Vertical Valid	tVV	2160	2160	2160	tHP	
	Vertical Back Porch	tVBP	54	54	54		
	Vertical Front Porch	tVFP	3	3	3		
	Vertical Blank	-	62	62	62		tWV+ tVBP+ tVFP

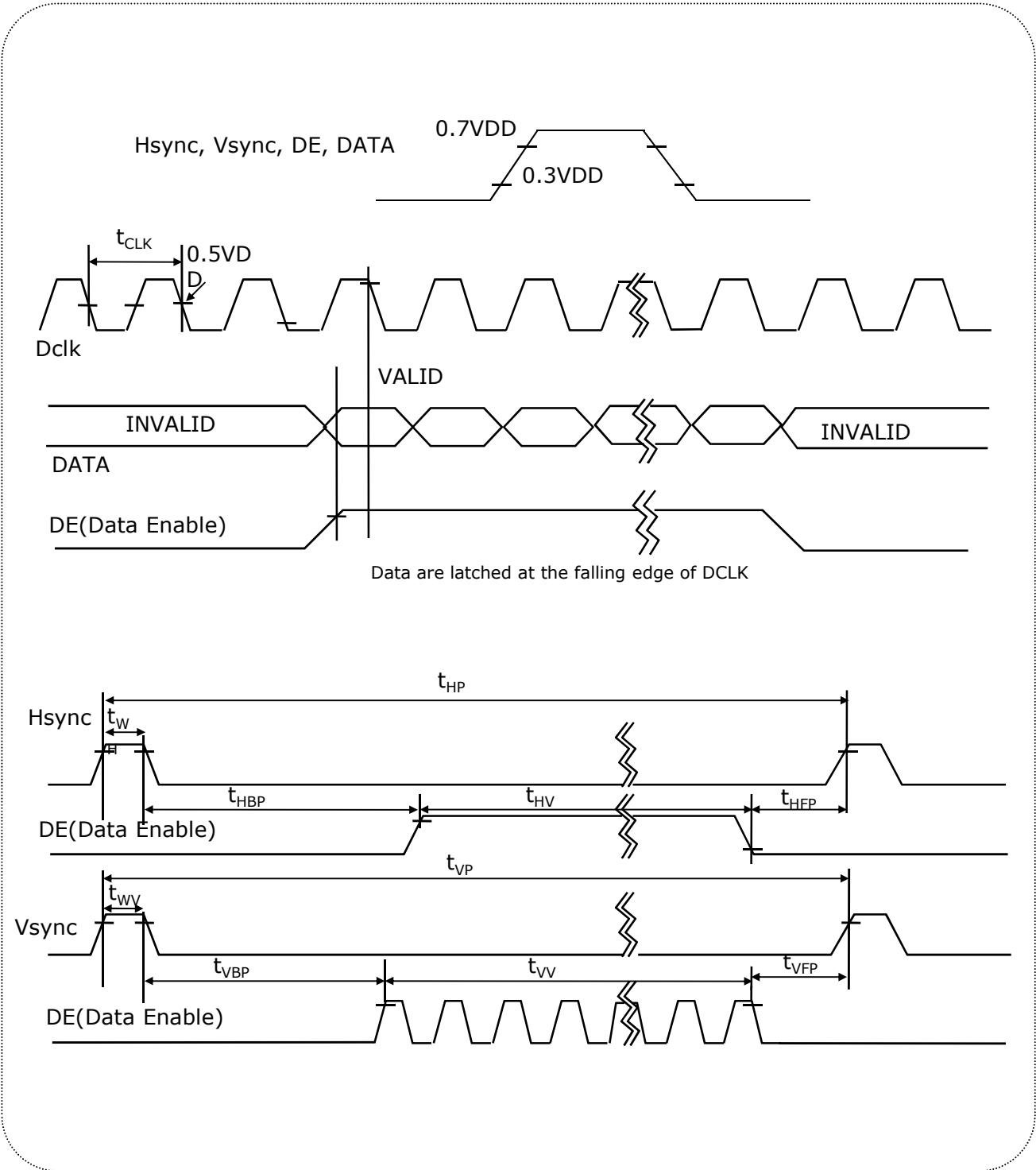
**Note:**

1. DE Only mode operation. The input of Hsync & Vsync signal does not have an effect on LCD normal operation.
2. The performance of the electro-optical characteristics may be influenced by variance of the vertical refresh rates.
3. Horizontal period should be even.



Product Specification

3-5. Signal Timing Waveforms



**Product Specification**

### 3-6. Color Input Data Reference

The Brightness of each primary color(red,green,blue) is based on the 10-bit gray scale data input for the color; the higher the binary input, the brighter the color. The table below provides a reference for color versus data input.

**Table 5. COLOR DATA REFERENCE**

Color		Input Color Data																													
		RED										GREEN										BLUE									
		MSB					LSB					MSB					LSB					MSB					LSB				
		R9	R8	R7	R6	R5	R4	R3	R2	R1	R0	G9	G8	G7	G6	G5	G4	G3	G2	G1	G0	B9	B8	B7	B6	B5	B4	B3	B2	B1	B0
Basic Color	Black	0	0	0	0	0	0	0	0	0	0	0	0	0	0	0	0	0	0	0	0	0	0	0	0	0	0	0	0	0	0
	Red (1023)	1	1	1	1	1	1	1	1	1	1	0	0	0	0	0	0	0	0	0	0	0	0	0	0	0	0	0	0	0	0
	Green (1023)	0	0	0	0	0	0	0	0	0	0	1	1	1	1	1	1	1	1	1	1	0	0	0	0	0	0	0	0	0	0
	Blue (1023)	0	0	0	0	0	0	0	0	0	0	0	0	0	0	0	0	0	0	0	0	1	1	1	1	1	1	1	1	1	1
	Cyan	0	0	0	0	0	0	0	0	0	0	1	1	1	1	1	1	1	1	1	1	1	1	1	1	1	1	1	1	1	1
	Magenta	1	1	1	1	1	1	1	1	1	1	0	0	0	0	0	0	0	0	0	0	1	1	1	1	1	1	1	1	1	1
	Yellow	1	1	1	1	1	1	1	1	1	1	1	1	1	1	1	1	1	1	1	1	0	0	0	0	0	0	0	0	0	0
	White	1	1	1	1	1	1	1	1	1	1	1	1	1	1	1	1	1	1	1	1	1	1	1	1	1	1	1	1	1	1
RED	RED (000)	0	0	0	0	0	0	0	0	0	0	0	0	0	0	0	0	0	0	0	0	0	0	0	0	0	0	0	0	0	
	RED (001)	0	0	0	0	0	0	0	0	0	0	0	0	0	0	0	0	0	0	0	0	0	0	0	0	0	0	0	0	0	
	...	...										...										...									
	RED (1022)	1	1	1	1	1	1	1	1	1	0	0	0	0	0	0	0	0	0	0	0	0	0	0	0	0	0	0	0	0	0
	RED (1023)	1	1	1	1	1	1	1	1	1	1	0	0	0	0	0	0	0	0	0	0	0	0	0	0	0	0	0	0	0	0
GREEN	GREEN (000)	0	0	0	0	0	0	0	0	0	0	0	0	0	0	0	0	0	0	0	0	0	0	0	0	0	0	0	0	0	
	GREEN (001)	0	0	0	0	0	0	0	0	0	0	0	0	0	0	0	0	0	0	0	0	0	0	0	0	0	0	0	0	0	
	...	...										...										...									
	GREEN (1022)	0	0	0	0	0	0	0	0	0	0	1	1	1	1	1	1	1	1	1	0	0	0	0	0	0	0	0	0	0	0
	GREEN (1023)	0	0	0	0	0	0	0	0	0	0	1	1	1	1	1	1	1	1	1	1	0	0	0	0	0	0	0	0	0	0
BLUE	BLUE (000)	0	0	0	0	0	0	0	0	0	0	0	0	0	0	0	0	0	0	0	0	0	0	0	0	0	0	0	0	0	
	BLUE (001)	0	0	0	0	0	0	0	0	0	0	0	0	0	0	0	0	0	0	0	0	0	0	0	0	0	0	0	0	1	
	...	...										...										...									
	BLUE (1022)	0	0	0	0	0	0	0	0	0	0	0	0	0	0	0	0	0	0	0	0	1	1	1	1	1	1	1	1	0	0
	BLUE (1023)	0	0	0	0	0	0	0	0	0	0	0	0	0	0	0	0	0	0	0	0	1	1	1	1	1	1	1	1	1	1

Product Specification

3-7. Power Sequence

3-7-1. Power Sequence

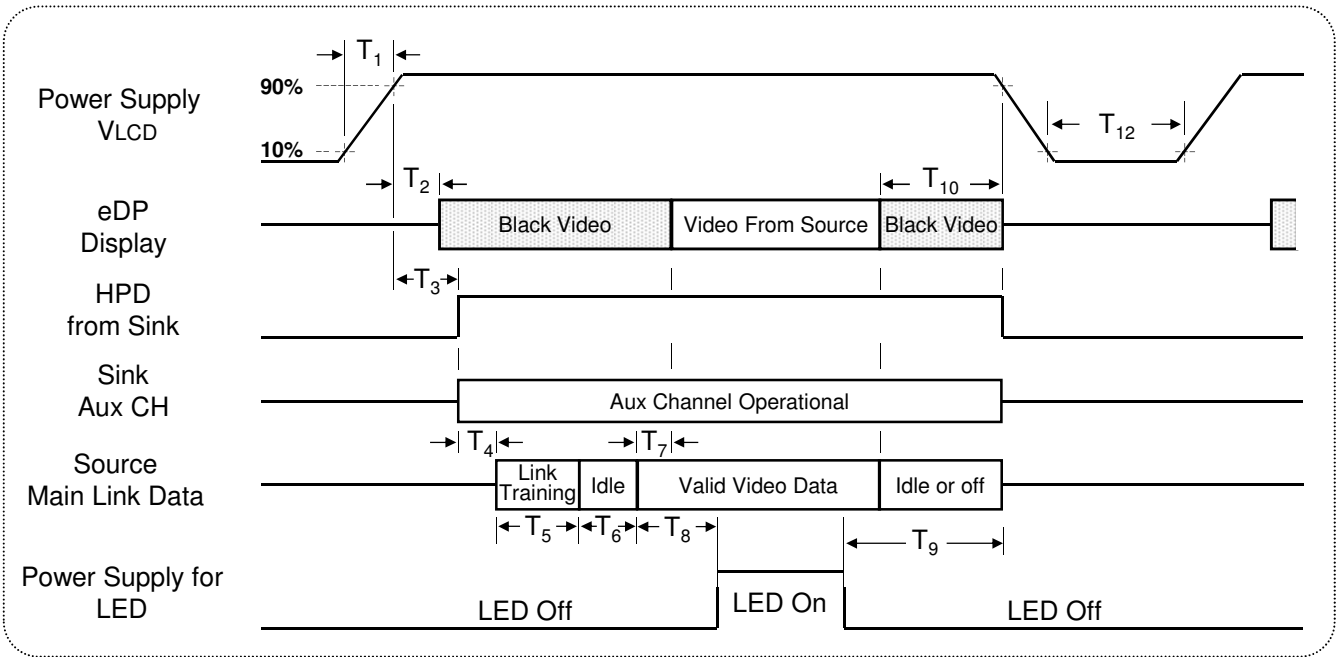


Table 6. POWER SEQUENCE TABLE

Timing	Required By	Limits		Units	Notes
		Min	Max		
T <sub>1</sub>	Source	0.5	10	ms	-
T <sub>2</sub>	Sink	10	200	ms	-
T <sub>3</sub>	Sink	15	200	ms	-
T <sub>4</sub>	Source	-	-	ms	6
T <sub>5</sub>	Source	-	-	ms	6
T <sub>6</sub>	Source	-	100	ms	-
T <sub>7</sub>	Sink	0	50	ms	-
T <sub>8</sub>	Source	200	-	ms	
T <sub>9</sub>	Source	200	-	ms	7

Timing	Required By	Limits		Units	Notes
		Min	Max		
T <sub>10</sub>	Source	0	500	ms	-
T <sub>12</sub>	Source	1000	-	ms	

- Note)
- Do not insert the mating cable when system turn on.
  - Valid Data have to meet "3-3. Signal Timing Specifications"
  - When the Video signal is invalid, be sure to pull down the power supply for LCD VLCD to 0V.
  - The above power sequence should be satisfied the basic power on/off and resolution, timing transition.
  - LED power must be turn on after power supply for LCD and valid status of Video Signal.
  - Link training duration is dependent on the customer's system.
  - LED power must be turned off while Video data signal is valid

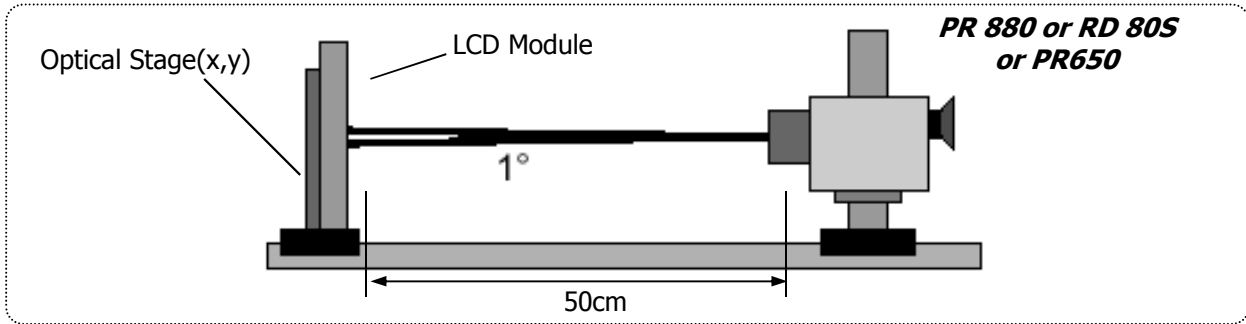


**Product Specification**

### 4. Optical Specifications

Optical characteristics are determined after the unit has been 'ON' for approximately 30 minutes in a dark environment at  $25 \pm 2^\circ\text{C}$ . The values specified are at an approximate distance 50cm from the LCD surface at a viewing angle of  $\Phi$  and  $\theta$  equal to  $0^\circ$  and aperture 1 degree.

FIG. 6 presents additional information concerning the measurement equipment and method.



**FIG.7 Optical Characteristic Measurement Equipment and Method**

**Table 7. OPTICAL CHARACTERISTICS** ( $T_a=25^\circ\text{C}$ ,  $V_{LCD}=10\text{V}$ ,  $f_v=60\text{Hz}$  Dclk=533.25 MHz,  $I_s=130\text{ mA}$ )

Parameter	Symbol	Values			Units	Notes	
		Min	Typ	Max			
Contrast Ratio	CR	910	1300	-		1	
Surface Luminance, white	$L_{WH}$	280	350	-	cd/m <sup>2</sup>	2	
Luminance Variation	$\delta_{WHITE}$	75	-	-	%	3	
Response Time	Gray To Gray	$T_{GTG\_AVR}$	-	14	25	ms	4
Color Coordinates [CIE1931] <i>(By PR650)</i>	RED	Rx	Typ -0.03	TBD	Typ +0.03		
		Ry		TBD			
	GREEN	Gx		TBD			
		Gy		TBD			
	BLUE	Bx		TBD			
		By		TBD			
	WHITE	Wx		0.313			
	Wy	0.329					
Color Shift	Horizontal	$\theta_{CST\_H}$	-	178	-	Degree	5
	Vertical	$\theta_{CST\_V}$	-	178	-		
Viewing Angle (CR>10)							
General	Horizontal	$\theta_H$	170	178	-	Degree	6
	Vertical	$\theta_V$	170	178	-		
Gray Scale		-		2.2			7

Product Specification

Notes 1. Contrast Ratio(CR) is defined mathematically as : **(By PR880)**

$$\text{Contrast Ratio} = \frac{\text{Surface Luminance with all white pixels}}{\text{Surface Luminance with all black pixels}}$$

It is measured at center point(Location P1)

2. Surface luminance(L<sub>WH</sub>)is luminance value at Center 1 point(P1) across the LCD surface 50cm from the surface with all pixels displaying white. For more information see FIG.8 (By PR880)

3. The variation in surface luminance , δ WHITE is defined as : **(By PR880)**

$$\delta_{WHITE} = \frac{\text{Minimum}(L_{P1}, L_{P2}, \dots, L_{P9})}{\text{Maximum}(L_{P1}, L_{P2}, \dots, L_{P9})} \times 100$$

Where L1 to L9 are the luminance with all pixels displaying white at 9 locations.  
For more information see FIG.8

4. Gray to gray response time is the time required for the display to transition from gray to gray. For additional information see Table 8. **( By PR880 )**

5. Color shift is the angle at which the average color difference for all Macbeth is lower than 0.02. For more information see FIG.10 **(By EZ Contrast)**

- Color difference (Δu'v')

$$u' = \frac{4x}{-2x + 12y + 3} \quad v' = \frac{9y}{-2x + 12y + 3} \quad \Delta u'v' = \sqrt{(u'_1 - u'_2)^2 + (v'_1 - v'_2)^2}$$

$$\text{Avg}(\Delta u'v') = \frac{\sum_{i=1}^{24} (\Delta u'v')_i}{24}$$

u'1, v'1 : u'v' value at viewing angle direction  
u'2, v'2 : u'v' value at front (θ=0)  
i : Macbeth chart number (Define 23 page)

- Pattern size : 25% Box size

- Viewing angle direction of color shift : Horizontal, Vertical

6. Viewing angle is the angle at which the contrast ratio is greater than 10. The angles are determined for the horizontal or x axis and the vertical or y axis with respect to the z axis which is normal to the LCD surface. For more information see FIG.11 **(By PR880)**

7. Gamma Value is approximately 2.2. For more information see Table 9.

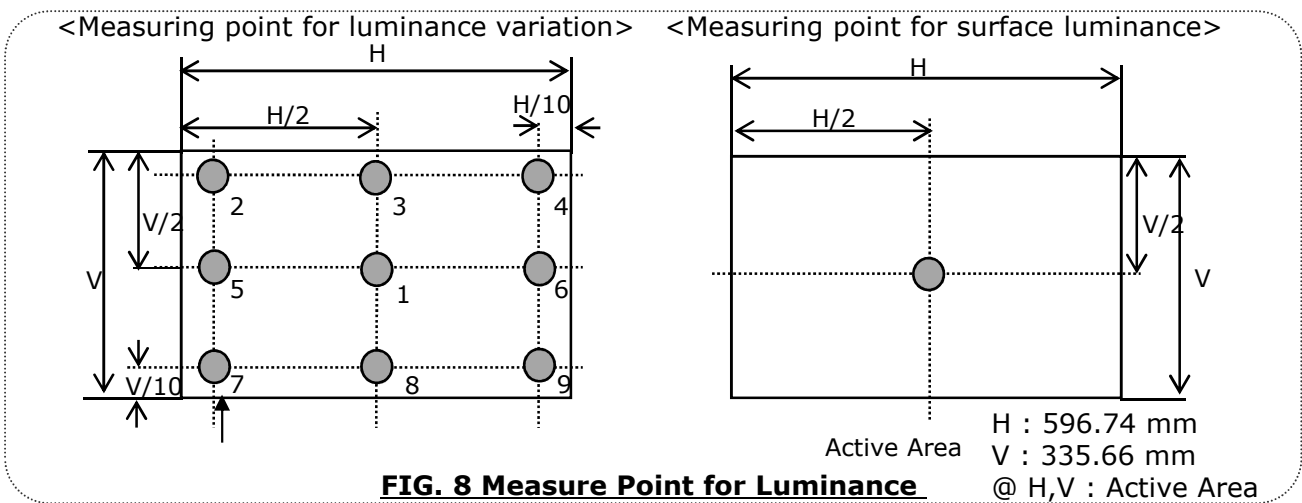
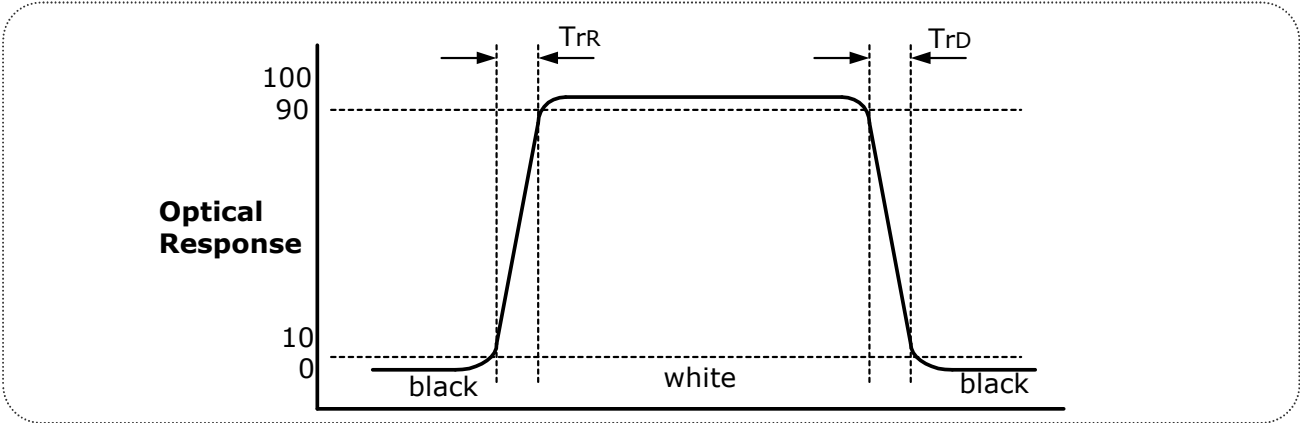


FIG. 8 Measure Point for Luminance

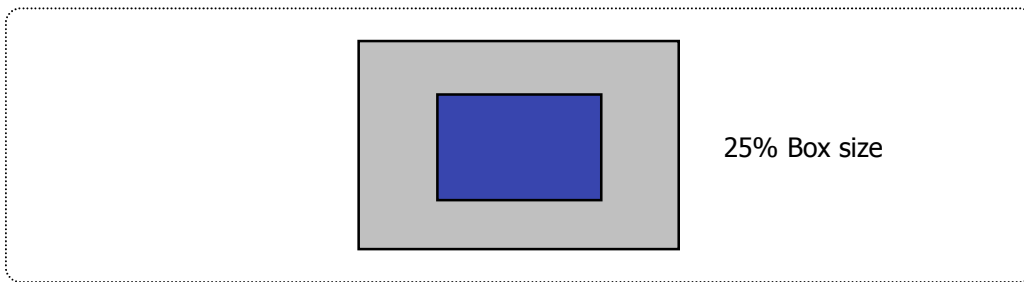
**Product Specification**

The response time is defined as the following figure and shall be measured by switching the input signal for "black" and "white".



**FIG.9 Response time**

Color shift is defined as the following test pattern and color.



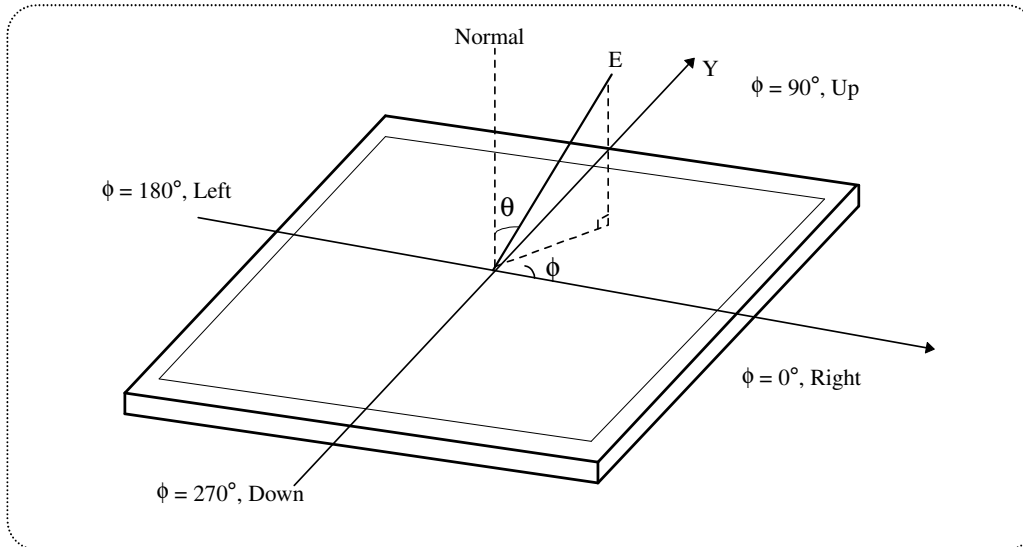
**FIG.10 Color Shift Test Pattern**

Average RGB values in Bruce RGB for Macbeth Chart

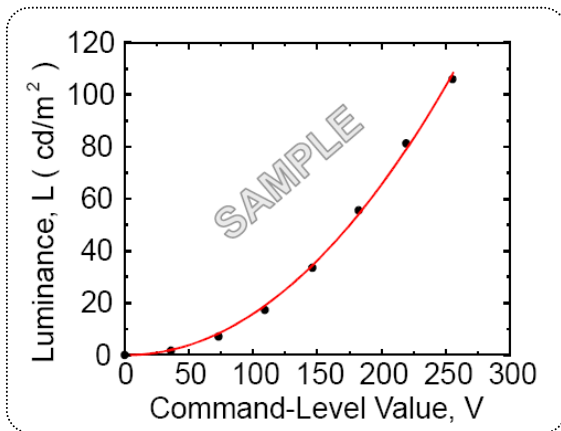
	Dark skin	Light skin	Blue sky	Foliage	Blue flower	Bluish green
R	395	827	343	311	519	459
G	227	571	451	411	475	799
B	183	495	647	187	743	715
	Orange	Purplish blue	Moderate red	Purple	Yellow green	Orange yellow
R	879	227	847	307	643	923
G	419	279	271	159	775	651
B	99	699	351	347	235	119
	Blue	Green	Red	Yellow	Magenta	cyan
R	107	291	791	967	831	143
G	131	595	111	851	251	507
B	583	263	151	147	607	691
	White	Neutral 8	Neutral 6.5	Neutral 5	Neutral 3.5	black
R	963	827	623	443	255	91
G	963	827	623	443	255	91
B	963	827	623	443	255	91

**Product Specification**

Dimension of viewing angle range.

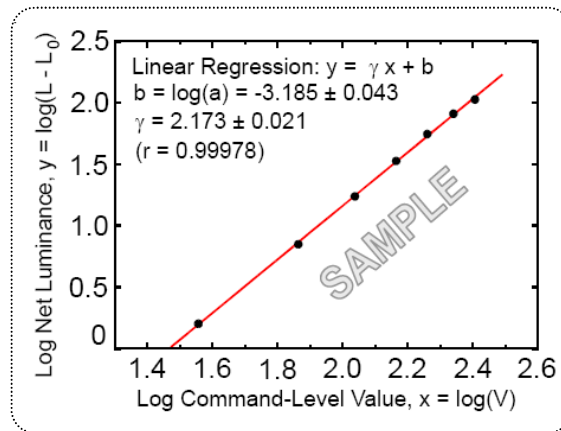


**FIG.11 Viewing angle**



**FIG.12 Sample Luminance vs. gray scale (using a 256 bit gray scale)**

$$L = aV^r + L_b$$



**FIG.13 Sample Log-log plot of luminance vs. gray scale**

$$\log(L - L_b) = r \log(V) + \log(a)$$

Here the Parameter  $a$  and  $\gamma$  relate the signal level  $V$  to the luminance  $L$ .  
The GAMMA we calculate from the log-log representation (FIG.12)



Product Specification

**Table 8. Gray to gray response time table**

Gray to Gray		Rising Time				
		G1023	G767	G511	G255	G0
Falling Time	G1023					
	G767					
	G511					
	G255					
	G0					

**Table 9. Gray Scale Specification**

Gray Level	Relative Luminance [%] (Typ.)
0	0.10
63	0.30
127	1.08
191	2.50
255	4.71
319	7.70
383	11.52
447	16.18
511	21.72
575	28.15
639	35.51
703	43.81
767	53.07
831	63.30
895	74.52
959	86.75
1023	100

Product Specification

**5. Mechanical Characteristics**

The contents provide general mechanical characteristics. In addition the figures in the next page are detailed mechanical drawing of the LCD.

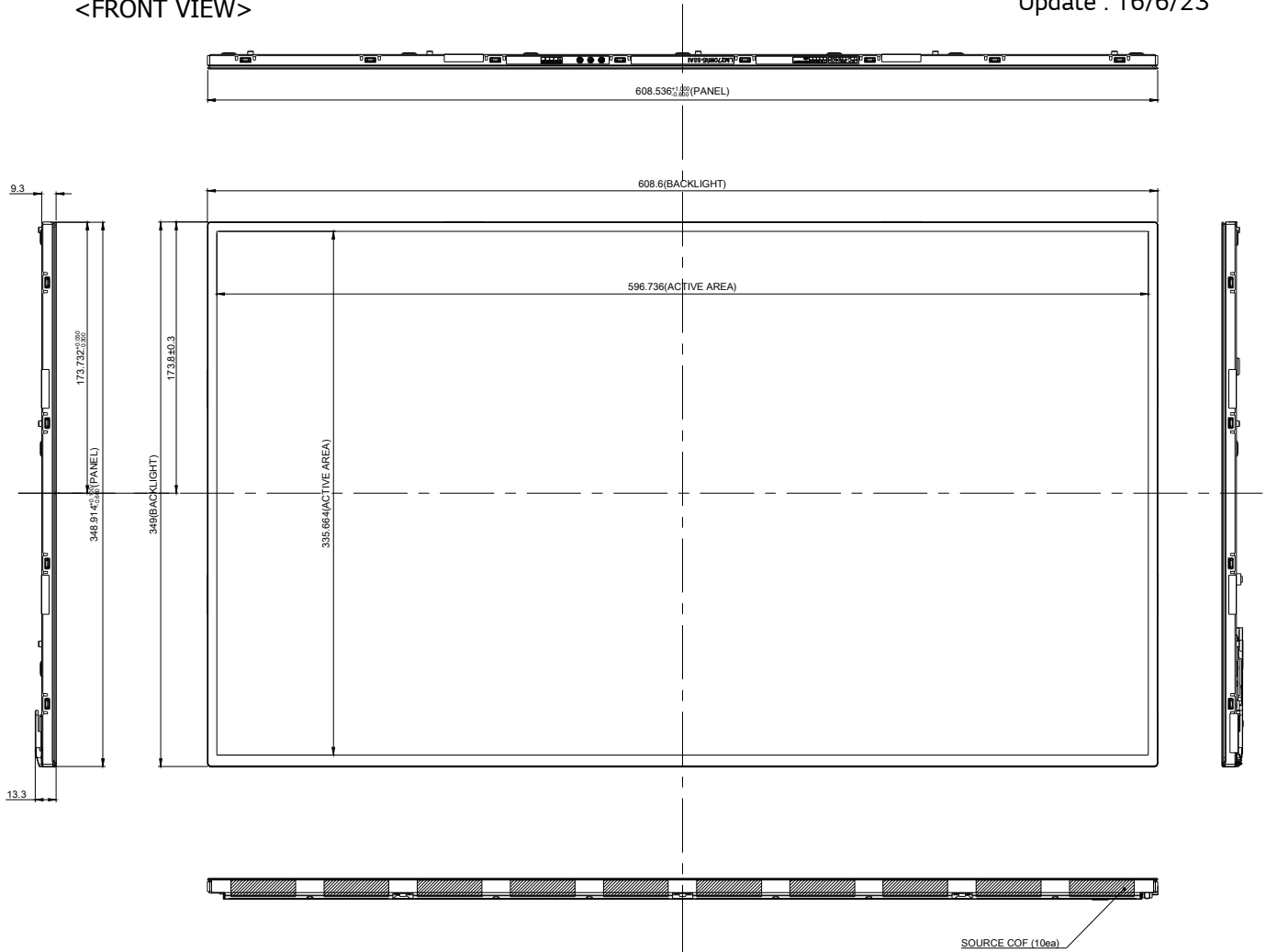
Outline Dimension	Horizontal	608.6mm
	Vertical	349mm
	Depth	13.3mm
Bezel Area	Horizontal	-
	Vertical	-
Active Display Area	Horizontal	596.74mm
	Vertical	335.66mm
Weight	2,266g (Typ.) / 2,379g (Max.)	
Surface Treatment	Advanced Anti-glare treatment of the front polarizer (3H)	

Notes : Please refer to a mechanic drawing in terms of tolerance at the next page.

**Product Specification**

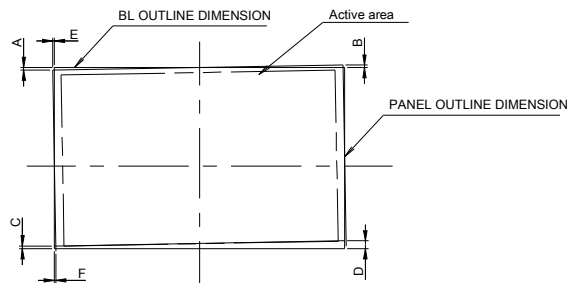
<FRONT VIEW>

Update : 16/6/23



**Notes**

1. I/F connector specification : LSMtron, GT05Q-30S-H10-MN or Equivalent.
2. LED connector specification: SM06B-SHJH (HF) (Manufactured by JST) or Equivalent
3. Torque of user hole: 3.0~4.0kgf-cm.
4. Tilt and partial disposition tolerance of display area as following
  - (1) Y-direction
    - a. Upper side :  $-0.45 < A < 0.45, -0.45 < B < 0.45$
    - b. Lower side :  $-0.45 < C < 0.6, -0.45 < D < 0.6$
  - (2) X-direction :  $-0.45 < E < 0.45, -0.45 < F < 0.45$

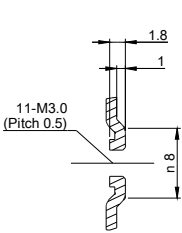
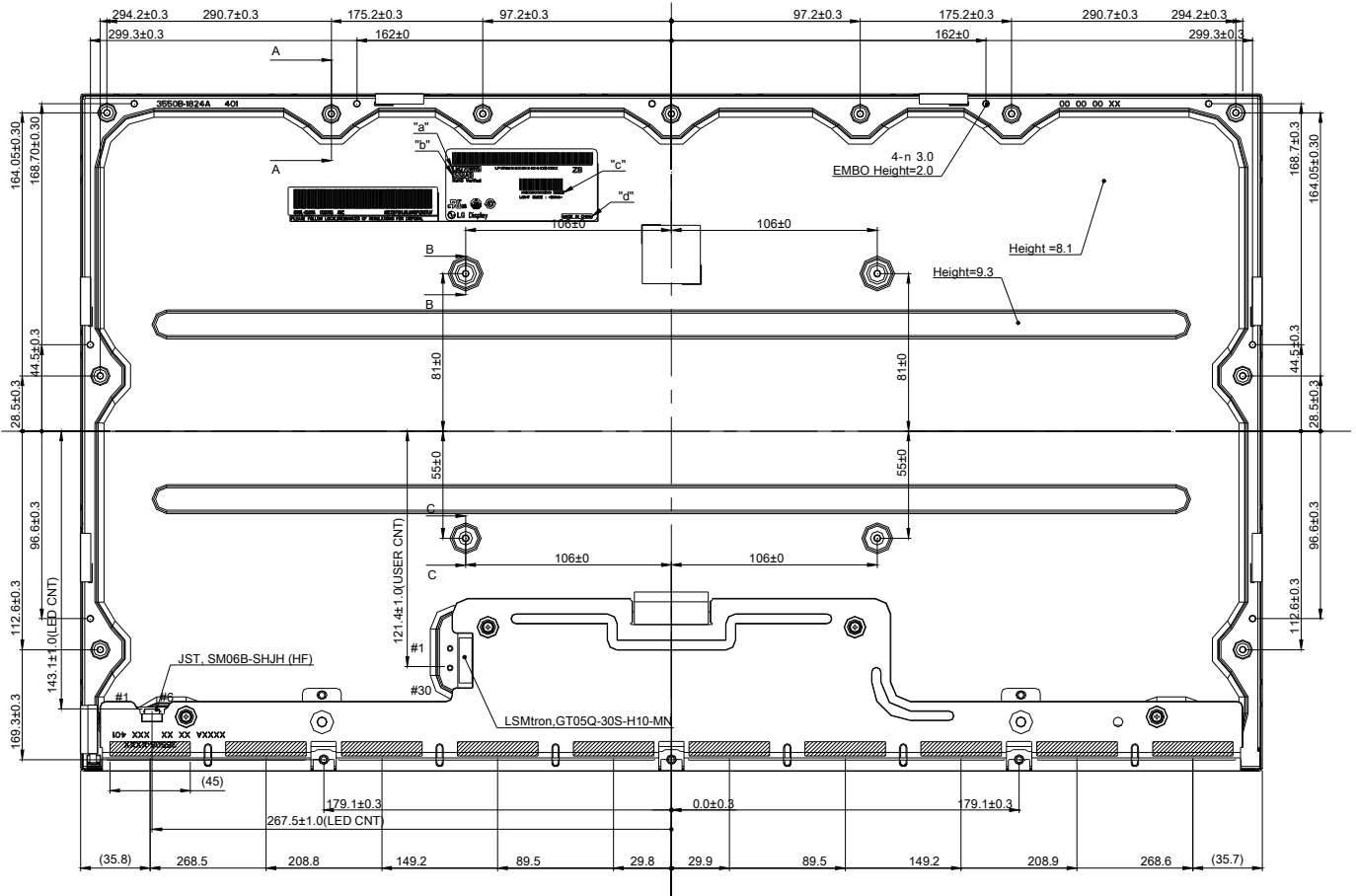


5. Unspecified tolerances to be  $\pm 0.5$
6. The LCM warp(warpage) is less than 1.0 on the surface plate
7. The COF area is weak & sensitive, so please don't press the COF area

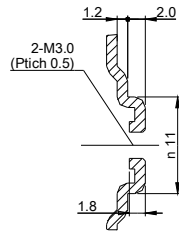
**Product Specification**

<REAR VIEW>

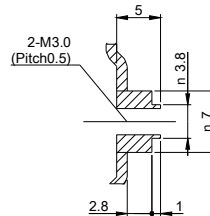
Update : 16/6/23



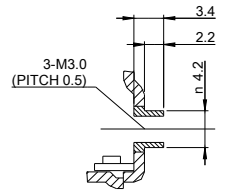
SECTION A-A  
SCALE 2/1



SECTION B-B  
SCALE 2/1



SECTION C-C  
SCALE 2/1



SECTION D-D  
SCALE 2/1

Product Specification

## 6. Reliability

Environment test condition

No	Test Item	Condition	Notes
1	High temperature storage test	Ta= 60°C 240h	1
2	Low temperature storage test	Ta= -20°C 240h	1
3	High temperature operation test	Ta= 50°C 50%RH 240h	1
4	Low temperature operation test	Ta= 0°C 240h	1
5	Altitude operating storage / shipment	0 - 16,400 feet(5,000m) 0 - 40,000 feet(12,192m)	

Note 1. Result Evaluation Criteria:

TFT-LCD panels test should take place after cooling enough at room temperature.

In the standard condition, there should be no particular problems that may affect the display function.

※. T<sub>a</sub>= Ambient Temperature

## **7. International Standards**

### **7-1. Safety**

- a) UL 60950-1, Underwriters Laboratories Inc.  
Information Technology Equipment - Safety - Part 1 : General Requirements.
- b) CAN/CSA-C22.2 No. 60950-1-07, Canadian Standards Association.  
Information Technology Equipment - Safety - Part 1 : General Requirements.
- c) EN 60950-1, European Committee for Electrotechnical Standardization (CENELEC).  
Information Technology Equipment - Safety - Part 1 : General Requirements.
- d) IEC 60950-1, The International Electrotechnical Commission (IEC).  
Information Technology Equipment - Safety - Part 1 : General Requirements

### **7-2. Environment**

- a) RoHS, Directive 2011/65/EU of the European Parliament and of the council of 8 June 2011

Product Specification

## 8. Packing

### 8-1. Designation of Lot Mark

a) Lot Mark

A	B	C	D	E	F	G	H	I	J	K	L	M
---	---	---	---	---	---	---	---	---	---	---	---	---

A,B,C : SIZE(INCH)  
E : MONTH

D : YEAR  
F ~ M : SERIAL NO.

Note

1. YEAR

Year	2011	2012	2013	2014	2015	2016	2017	2018	2019	2020
Mark	A	B	C	D	E	F	G	H	J	K

2. MONTH

Month	Jan	Feb	Mar	Apr	May	Jun	Jul	Aug	Sep	Oct	Nov	Dec
Mark	1	2	3	4	5	6	7	8	9	A	B	C

b) Location of Lot Mark

Serial No. is printed on the label. The label is attached to the backside of the LCD module.  
This is subject to change without prior notice.

### 8-2. Packing Form

1) Package quantity in one box : 10ea

b) Box Size : 710mm X 365mm X 448mm

## Product Specification

**9. PRECAUTIONS**

Please pay attention to the followings when you use this TFT LCD module.

**9-1. MOUNTING PRECAUTIONS**

- (1) You must mount a module using holes arranged in four corners or four sides.
- (2) You should consider the mounting structure so that uneven force (ex. Twisted stress) is not applied to the module. And the case on which a module is mounted should have sufficient strength so that external force is not transmitted directly to the module.
- (3) Please attach the surface transparent protective plate to the surface in order to protect the polarizer. Transparent protective plate should have sufficient strength in order to resist external force.
- (4) You should adopt radiation structure to satisfy the temperature specification.
- (5) Acetic acid type and chlorine type materials for the cover case are not desirable because the former generates corrosive gas of attacking the polarizer at high temperature and the latter causes circuit break by electro-chemical reaction.
- (6) Do not touch, push or rub the exposed polarizers with glass, tweezers or anything harder than HB pencil lead. And please do not rub with dust clothes with chemical treatment. Do not touch the surface of polarizer for bare hand or greasy cloth. (Some cosmetics are detrimental to the polarizer.)
- (7) When the surface becomes dusty, please wipe gently with absorbent cotton or other soft materials like chamois soaks with petroleum benzene. Normal-hexane is recommended for cleaning the adhesives used to attach front / rear polarizers. Do not use acetone, toluene and alcohol because they cause chemical damage to the polarizer.
- (8) Wipe off saliva or water drops as soon as possible. Their long time contact with polarizer causes deformations and color fading.
- (9) Do not open the case because inside circuits do not have sufficient strength.
- (10) As The IPS panel is sensitive & slim, please recommend the metal frame of the system supports the panel by the double side-mount.

**9-2. OPERATING PRECAUTIONS**

- (1) The spike noise causes the mis-operation of circuits. It should be lower than following voltage :  
 $V = \pm 200\text{mV}$  (Over and under shoot voltage)
- (2) Response time depends on the temperature. (In lower temperature, it becomes longer.)
- (3) Brightness depends on the temperature. (In Higher temperature, it becomes lower.)  
And in lower temperature, response time (required time that brightness is stable after turned on) becomes longer.
- (4) Be careful for condensation at sudden temperature change. Condensation makes damage to polarizer or electrical contacted parts. And after fading condensation, smear or spot will occur.
- (5) When fixed patterns are displayed for a long time, remnant image is likely to occur.
- (6) Module has high frequency circuits. Sufficient suppression to the electromagnetic interference shall be done by system manufacturers. Grounding and shielding methods may be important to minimized the interference.
- (7) Please do not give any mechanical and/or acoustical impact to LCM. Otherwise, LCM can't be operated its full characteristics perfectly.
- (8) A screw which is fastened up the steels should be a machine screw.  
(if not, it causes metallic foreign material and deal LCM a fatal blow)
- (9) Please do not set LCD on its edge.
- (10) When LCMs are used for public display defects such as Yogore, image sticking can not be guarantee.
- (11) LCMs cannot support "Interlaced Scan Method"
- (12) Please conduct image sticking test after 2-hour aging with Rolling PTN and normal temperature (25~40°C)
- (13) When this reverse model is used as a forward-type model (PCB on top side), LGD can not guarantee any defects of LCM.



### **9-3. ELECTROSTATIC DISCHARGE CONTROL**

Since a module is composed of electronic circuits, it is not strong to electrostatic discharge. Make certain that treatment persons are connected to ground through wrist band etc. And don't touch interface pin directly.

### **9-4. PRECAUTIONS FOR STRONG LIGHT EXPOSURE**

Strong light exposure causes degradation of polarizer and color filter.

### **9-5. STORAGE**

When storing modules as spares for a long time, the following precautions are necessary.

- (1) Store them in a dark place. Do not expose the module to sunlight or fluorescent light. Keep the temperature between 5°C and 35°C at normal humidity.
- (2) The polarizer surface should not come in contact with any other object.  
It is recommended that they be stored in the container in which they were shipped.

### **9-6. HANDLING PRECAUTIONS FOR PROTECTION FILM**

- (1) The protection film is attached to the bezel with a small masking tape.  
When the protection film is peeled off, static electricity is generated between the film and polarizer.  
This should be peeled off slowly and carefully by people who are electrically grounded and with well ion-blown equipment or in such a condition, etc.
- (2) When the module with protection film attached is stored for a long time, sometimes there remains a very small amount of glue still on the bezel after the protection film is peeled off.
- (3) You can remove the glue easily. When the glue remains on the bezel surface or its vestige is recognized, please wipe them off with absorbent cotton waste or other soft material like chamois soaked with normal-hexane.