

## ***TFT-Display Datenblatt***

Modell LM270WQ1-SDE3

### **Kurzdaten**

Hersteller	LG Display
Diagonale	27" / 68,6 cm
Format	16:9
Auflösung	2560 x 1440
Backlight	LED / 420 cd/m <sup>2</sup>
Interface	RGB
Touchscreen	nein
Temperatur	0... +50°C (Betrieb)



**Product Specification**
Contents

No	ITEM	Page
	COVER	1
	CONTENTS	2
	RECORD OF REVISIONS	4
1	GENERAL DESCRIPTION	5
2	ABSOLUTE MAXIMUM RATINGS	6
3	ELECTRICAL SPECIFICATIONS	7
3-1	ELECTRICAL CHARACTERISTICS	7
3-2	INTERFACE CONNECTIONS	10
3-3	SIGNAL TIMING SPECIFICATIONS	13
3-4	SIGNAL TIMING WAVEFORMS	16
3-5	COLOR INPUT DATA REFERENCE	17
3-6	POWER SEQUENCE	18
4	OPTICAL SPECIFICATIONS	22
5	MECHANICAL CHARACTERISTICS	28
6	RELIABILITY	31
7	INTERNATIONAL STANDARDS	32
7-1	SAFETY	32
7-2	EMC	32
8	PACKING	33
8-1	DESIGNATION OF LOT MARK	33
8-2	PACKING FORM	33
9	PRECAUTIONS	34
9-1	MOUNTING PRECAUTIONS	34
9-2	OPERATING PRECAUTIONS	34
9-3	ELECTROSTATIC DISCHARGE CONTROL	35
9-4	PRECAUTIONS FOR STRONG LIGHT EXPOSURE	35
9-5	STORAGE	35
9-6	HANDLING PRECAUTIONS FOR PROTECTION FILM	35

**Product Specification**Contents

No	ITEM	Page
10	EDID DATA	36
10-1	EDID DATA	36
10-2	EDID READ/WRITE PROTOCOL	39

LGD\_BSK\_120508



**Product Specification**

**1. General Description**

LM270WQHD is a Color Active Matrix Liquid Crystal Display with Light Emitting Diode ( White LED) backlight system without LED driver. The matrix employs a-Si Thin Film Transistor as the active element. It is a transmissive type display operating in the normally black mode. It has a 27inch diagonally measured active display area with QHD resolution (2560 vertical by 1440 horizontal pixel array) Each pixel is divided into Red, Green and Blue sub-pixels or dots which are arranged in vertical stripes. Gray scale or the brightness of the sub-pixel color is determined with a 10-bit gray scale signal for each dot, thus, presenting a palette of more than 1.07B colors with FRC (Frame Rate Control).

It has been designed to apply the 10-bit 4Lane Display port interface.

It is intended to support displays where high brightness, super wide viewing angle, high color saturation, and high color are important.

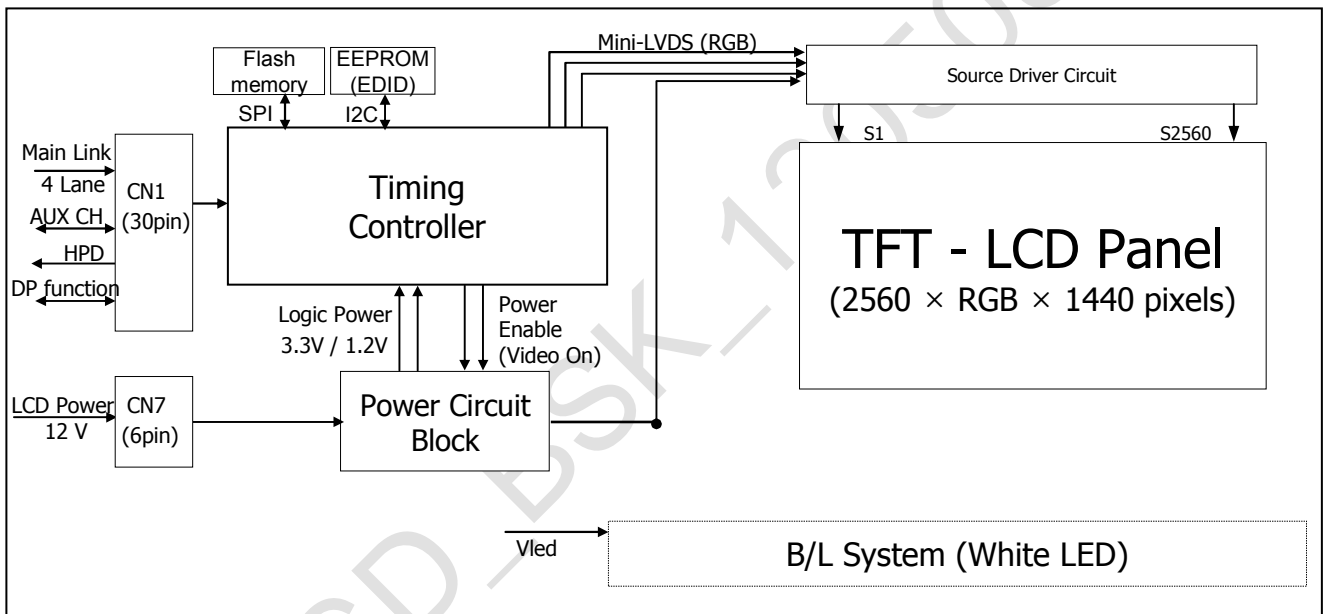

**General Features**

Active Screen Size	27.0 inches(68.47cm) diagonal
Outline Dimension	630.0(H) x 376.13(V) x 21.8(D) mm(Typ.)
Pixel Pitch	0.2331 mm x 0.2331 mm
Pixel Format	2560 horiz. By 1440 vert. Pixels RGB stripes arrangement
Color Depth	8-bit, 16,777,216 colors
Luminance, White	420 cd/m <sup>2</sup> ( 5 points Avg.)
Viewing Angle(CR>10)	View Angle Free (R/L 178(Typ.), U/D 178(Typ.))
Power Consumption	Total 98.09 Watt (Max.) (17.94 Watt @V <sub>LCD</sub> , Max 80.15 Watt_Duty 100% of DC 350 mA_w/o driver)
Weight	4600 g (typ.)
Display Operating Mode	Transmissive mode, normally black
Surface Treatment	Glare (Low Reflection treatment of the front polarizer)
HDCP	HDCP key implemented in Tcon (DP628)



## Product Specification

**3. Electrical Specifications**
**3-1. Electrical Characteristics**

It requires two power inputs. One is employed to power the LCD electronics and to drive the TFT array and liquid crystal. The second input power for the DP Rx.

**Table 2-1-1. ELECTRICAL CHARACTERISTICS (Normal Mode)**

Parameter	Symbol	Values			Unit	Notes
		Min	Typ	Max		
MODULE :						
Power Supply Input voltage	VLCD	11.4	12.0	12.6	Vdc	
Permissive Power Input Ripple	VdRF	-		400	mVp-p	
Power Supply Input Current	ILCD	-	900	1035	mA	1
		-	1300	1495	mA	2
Power Consumption	PLCD	-	10.8	12.42	Watt	1
			15.6	17.94	Watt	2
Rush Current	IRUSH_VLCD	-	-	3.0	A	3



Product Specification

Note :

- 1. The specified current and power consumption are under the  $V_{LCD}=12.0V$ ,  $25 \pm 2^{\circ}C$ ,  $f_v=60Hz$  condition whereas mosaic pattern(8 x 6) is displayed and  $f_v$  is the frame frequency.
- 2. The current is specified at the maximum current pattern.
- 3. The duration of rush current is about 2ms and rising time of power Input is 1ms(min.).

White : 255Gray  
Black : 0Gray

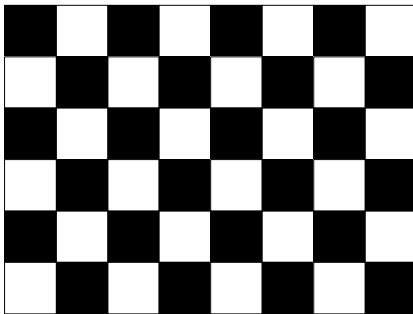

Mosaic Pattern(8 x 6)

Maximum current pattern

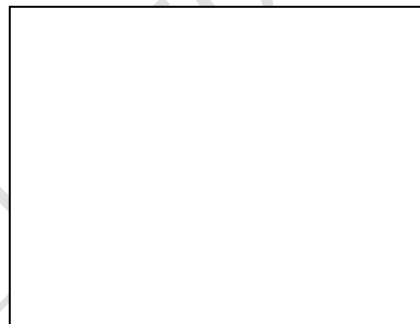

White Pattern

**Product Specification**
**Table 2-2. LED Bar ELECTRICAL CHARACTERISTICS**

Items	Symbol	Spec			Unit	Remark	Notes
		Min	Typ	Max			
LED String Voltage	$V_S$	31	36	41	Vrms	Ta=25°C, at DC 350 mA	2,7
LED Bar Voltage	$V_{Bar}$	-	216	229	Vrms	Ta=25°C, at DC 350 mA	3,7
LED String Power	$P_S$	10.85	12.6	14.35	W	Ta=25°C, at DC 350 mA	3,6,7
LED Bar Power	$P_L$	-	75.6	80.15	W	Ta=25°C, at DC 350 mA	4,6,7
BL Power	$P_{BL}$	-	75.6	80.15	W	Ta=25°C, at Duty 100% of DC 350 mA	6,7
LED Life Time	LED_LT	(39,000)		-	Hrs	Ta=25°C, at Duty 100% of DC 350 mA	5,7
LED Junction Temperature	Tj			150	°C	-	7

**LED driver design guide**

: The design of the LED driver must have specifications for the LED in LCD Assembly.

The performance of the LED in LCM, for example life time or brightness, is extremely influenced by the characteristics of the LED driver.

So all the parameters of an LED driver should be carefully designed and output current should be Constant current control.

Please control feedback current of each string individually to compensate the current variation among the strings of LEDs.

When you design or order the LED driver, please make sure unwanted lighting caused by the mismatch of the LED and the LED driver (no lighting, flicker, etc) never occurs.

When you confirm it, the LCD module should be operated in the same condition as installed in your instrument.

- Specified values are for a single LED bar including Left & Right Bar.
- The specified current is input LED chip 100% duty current.
- The specified voltage is input LED string and Bar voltage at typical 350 mA 100% duty current.
- The specified power consumption is input LED bar power consumption at typical 350 mA 100% duty current.
- The life is determined as the time at which luminance of the LED is 50% compared to that of initial value at the typical LED current on condition of continuous operating at  $25 \pm 2^\circ\text{C}$ .
- The LED power consumption shown above does not include loss of external driver.  
The used LED BL current is the LED typical current.  
String Power Consumption is calculated with  $P_S = V_S \times 350\text{mA}$   
Bar Power Consumption is calculated with  $P_L = V_{Bar} \times 350\text{mA}$   
BL Power Consumption is calculated with  $P_{BL} = V_{Bar} \times 350\text{mA}$
- LED operating DC Forward Current and Junction Temperature must not exceed LED Max Ratings.

Product Specification

**3-2. Interface Connections**

**3-2-1. LCD Module**

- LCD Connector(CN1) : 20525-030E-01 (manufactured by I-PEX)  
The pin configuration for the 30 pin connector is shown in the table below.

**Table 3-1. MODULE CONNECTOR(CN1) PIN CONFIGURATION**

No.	Symbol	Description	No.	Symbol	Description
1	GND	Ground	16	Lane0N	Components Signal for Main Link 0
2	DDC_SDA	DDC Data	17	GND	High Speed Ground for Main Link 1
3	DDC_SCL	DDC Clock	18	Lane1P	True Signal for Main Link 1
4	GND	Ground	19	Lane1N	Components Signal for Main Link 1
5	I2C_SDA	I2C Data	20	GND	High Speed Ground for Main Link 2
6	I2C_SCL	I2C Clock	21	Lane2P	True Signal for Main Link 2
7	GND	Ground	22	Lane2N	Components Signal for Main Link 2
8	SPDIF	Audio output from DP Rx	23	GND	High Speed Ground for Main Link 3
9	OPTION_1	TBD	24	Lane3P	True Signal for Main Link 3
10	HPD	Hot Plug Detect Signal	25	Lane3N	Components Signal for Main Link 3
11	GND	High Speed Ground for Auxiliary Channel	26	GND	High Speed Ground
12	AUX_CHN	Component Signal for Auxiliary	27	VIDEO_ON	Video status from DP Rx
13	AUX_CHP	True Signal for Auxiliary Channel	28	OPTION_2	TBD
14	GND	High Speed Ground for Main Link 0	29	VSYNC	Vertical sync output from DP Rx
15	Lane0P	True Signal for Main Link 0	30	GND	Ground

- Notes : 1. Connector  
 2.1 Connector(Receptacle) : 20525-030E-01(I-PEX)  
 2.2 Mating Connector(Plug) : 20523-030T-01(I-PEX)

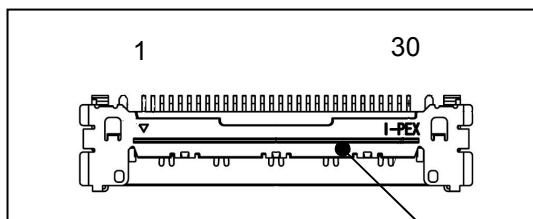

20525-030E-01 (I-PEX)

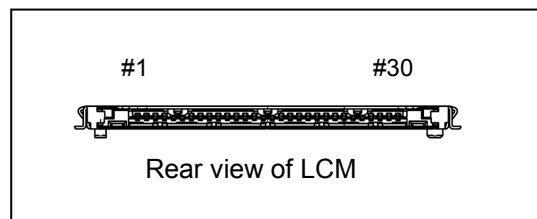

Rear view of LCM

Product Specification

### 3-2. Interface Connections

#### 3-2-1. LCD Module

- Power Connector(CN7) : 53780-8608 (manufactured by MOLEX)  
The pin configuration for the 6 pin connector is shown in the table below.

**Table 3-2. POWER CONNECTOR(CN7) PIN CONFIGURATION**

Pin	Symbol	Description	NOTES
1	GND	Ground	
2	GND	Ground	
3	GND	Ground	
4	VIN	12V for LCM main power	
5	VIN	12V for LCM main power	
6	VIN	12V for LCM main power	

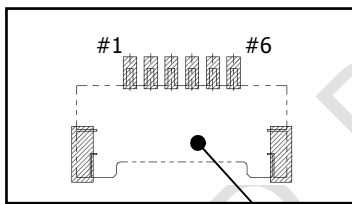

53780-8606

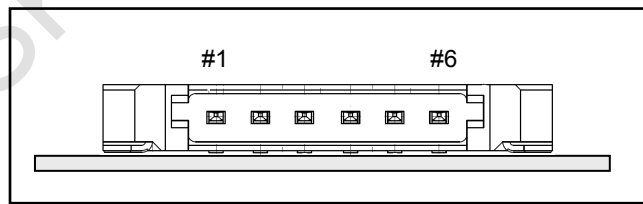

Rear view of LCM

#### 3-2-2. Sync Connector

- This connector is used for synchronized LED Driver.  
The connector is 53780-8604. (Manufactured by MOLEX)

**Table 4. LED SYNCHRONIZED CONNECTOR(CN4) PIN CONFIGURATION**

Pin	Symbol	Description	NOTES
1	DXP	Positive connection to remote temp. sensor	
2	DXN	Negative connection to remote temp. sensor	
3	GND	Ground	
4	VSYNCM	VSYNCM for synchronized LED Driver	

### 3-2-3. Backlight Interface

- LED Connector : **H401K-D12N-12B** (Manufactured by E&T)
- Mating Connector : **4530K-F12N-01R** (Manufactured by E&T)

**Table 5. LED CONNECTOR PIN CONFIGURATION**

Pin No.	Symbol	Description	Note
1	L_LED1+	LED channel 1 Anode	Left bar
2	L_LED1-	LED channel 1 Cathode	
3	L_LED2+	LED channel 2 Anode	
4	L_LED2-	LED channel 2 Cathode	
5	L_LED3+	LED channel 3 Anode	
6	L_LED3-	LED channel 3 Cathode	
7	R_LED1+	LED channel 1 Anode	Right bar
8	R_LED1-	LED channel 1 Cathode	
9	R_LED2+	LED channel 2 Anode	
10	R_LED2-	LED channel 2 Cathode	
11	R_LED3+	LED channel 3 Anode	
12	R_LED3-	LED channel 3 Cathode	

**Product Specification**

### 3-3. Signal Timing Specifications

All of the interface signal timing should be satisfied with the following specifications for it's proper operation.

**Table 6\_1. TIMING TABLE (VESA COORDINATED VIDEO TIMING)**

ITEM		SYMBOL	Min	Typ	Max	Unit	Note
DCLK	Period	tCLK	4.14	4.14	4.14	ns	
	Frequency	fCLK	241.5	241.5	241.5	MHz	-
Hsync	Period	tHP	2720	2720	2720	tCLK	
	Width-Active	tWH	32	32	32		
Vsync	Period	tVP	1481	1481	1481	tHP	
	Frequency	fV	59.95	59.95	59.95	Hz	
	Width-Active	tWV	5	5	5	tHP	
Data Enable	Horizontal Valid	tHV	2560	2560	2560	tCLK	
	Horizontal Back Porch	tHBP	80	80	80		
	Horizontal Front Porch	tHFP	48	48	48		
	Horizontal Blank	-	160	160	160		tWH+ tHBP+ tHFP
	Vertical Valid	tVV	1440	1440	1440	tHP	
	Vertical Back Porch	tVBP	33	33	33		
	Vertical Front Porch	tVFP	3	3	3		
	Vertical Blank	-	41	41	41		tWV+ tVBP+ tVFP

Note: Hsync period and Hsync width-active should be even number times of tCLK. If the value is odd number times of tCLK, display control signal can be asynchronous. In order to operate this LCM a Hsync, Vsync, and DE(data enable) signals should be used.

1. The performance of the electro-optical characteristics may be influenced by variance of the vertical refresh rates.
2. Vsync and Hsync should be keep the above specification.
3. Hsync Period, Hsync Width, and Horizontal Back Porch should be any times of of character number(8).
4. The polarity of Hsync, Vsync is not restricted.

**Product Specification**
**Table 6\_2. 1280x720 TIMING TABLE (VESA COORDINATED VIDEO TIMING)**

ITEM		SYMBOL	Min	Typ	Max	Unit	Note
DCLK	Period	tCLK	13.43	13.43	13.43	ns	
	Frequency	fCLK	74.5	74.5	74.5	MHz	-
Hsync	Period	tHP	1664	1664	1664	tCLK	
	Width-Active	tWH	128	128	128		
Vsync	Period	tVP	748	748	748	tHP	
	Frequency	fV	59.85	59.85	59.85	Hz	
	Width-Active	tWV	5	5	5	tHP	
Data Enable	Horizontal Valid	tHV	1280	1280	1280	tCLK	
	Horizontal Back Porch	tHBP	192	192	192		
	Horizontal Front Porch	tHFP	64	64	64		
	Horizontal Blank	-	384	384	384		tWH+ tHBP+ tHFP
	Vertical Valid	tVV	720	720	720	tHP	
	Vertical Back Porch	tVBP	20	20	20		
	Vertical Front Porch	tVFP	3	3	3		
	Vertical Blank	-	28	28	28		tWV+ tVBP+ tVFP

Note: Hsync period and Hsync width-active should be even number times of tCLK. If the value is odd number times of tCLK, display control signal can be asynchronous. In order to operate this LCM a Hsync, Vsync, and DE(data enable) signals should be used.

1. The performance of the electro-optical characteristics may be influenced by variance of the vertical refresh rates.
2. Vsync and Hsync should be keep the above specification.
3. Hsync Period, Hsync Width, and Horizontal Back Porch should be any times of of character number(8).
4. The polarity of Hsync, Vsync is not restricted.

**Product Specification**
**Table 6\_3. 1280x720 TIMING TABLE (CEA COORDINATED VIDEO TIMING)**

ITEM		SYMBOL	Min	Typ	Max	Unit	Note
DCLK	Period	tCLK	13.47	13.47	13.47	ns	
	Frequency	fCLK	74.25	74.25	74.25	MHz	-
Hsync	Period	tHP	1650	1650	1650	tCLK	
	Width-Active	tWH	40	40	40		
Vsync	Period	tVP	750	750	750	tHP	
	Frequency	fV	60.00	60.00	60.00	Hz	
	Width-Active	tWV	5	5	5	tHP	
Data Enable	Horizontal Valid	tHV	1280	1280	1280	tCLK	
	Horizontal Back Porch	tHBP	220	220	220		
	Horizontal Front Porch	tHFP	110	110	110		
	Horizontal Blank	-	370	370	370		tWH+ tHBP+ tHFP
	Vertical Valid	tVV	720	720	720	tHP	
	Vertical Back Porch	tVBP	20	20	20		
	Vertical Front Porch	tVFP	5	5	5		
	Vertical Blank	-	30	30	30		tWV+ tVBP+ tVFP

Note: Hsync period and Hsync width-active should be even number times of tCLK. If the value is odd number times of tCLK, display control signal can be asynchronous. In order to operate this LCM a Hsync, Vsync, and DE(data enable) signals should be used.

1. The performance of the electro-optical characteristics may be influenced by variance of the vertical refresh rates.
2. Vsync and Hsync should be keep the above specification.
3. Hsync Period, Hsync Width, and Horizontal Back Porch should be any times of of character number(8).
4. The polarity of Hsync, Vsync is not restricted.





**Product Specification**

### 3-5. Color Data Reference

The Brightness of each primary color(red,green,blue) is based on the 8-bit gray scale data input for the color; the higher the binary input, the brighter the color. The table below provides a reference for color versus data input.

**Table 7. COLOR DATA REFERENCE**

Color		Input Color Data																							
		RED								GREEN								BLUE							
		MSB				LSB				MSB				LSB				MSB				LSB			
		R7	R6	R5	R4	R3	R2	R1	R0	G7	G6	G5	G4	G3	G2	G1	G0	B7	B6	B5	B4	B3	B2	B1	B0
Basic Color	Black	0	0	0	0	0	0	0	0	0	0	0	0	0	0	0	0	0	0	0	0	0	0	0	0
	Red (255)	1	1	1	1	1	1	1	1	0	0	0	0	0	0	0	0	0	0	0	0	0	0	0	0
	Green (255)	0	0	0	0	0	0	0	0	1	1	1	1	1	1	1	1	0	0	0	0	0	0	0	0
	Blue (255)	0	0	0	0	0	0	0	0	0	0	0	0	0	0	0	0	1	1	1	1	1	1	1	1
	Cyan	0	0	0	0	0	0	0	0	1	1	1	1	1	1	1	1	1	1	1	1	1	1	1	1
	Magenta	1	1	1	1	1	1	1	1	0	0	0	0	0	0	0	0	1	1	1	1	1	1	1	1
	Yellow	1	1	1	1	1	1	1	1	1	1	1	1	1	1	1	1	0	0	0	0	0	0	0	0
	White	1	1	1	1	1	1	1	1	1	1	1	1	1	1	1	1	1	1	1	1	1	1	1	1
RED	RED (000) Dark	0	0	0	0	0	0	0	0	0	0	0	0	0	0	0	0	0	0	0	0	0	0	0	0
	RED (001)	0	0	0	0	0	0	0	1	0	0	0	0	0	0	0	0	0	0	0	0	0	0	0	0
	...	...								...								...							
	RED (254)	1	1	1	1	1	1	1	0	0	0	0	0	0	0	0	0	0	0	0	0	0	0	0	0
	RED (255)	1	1	1	1	1	1	1	1	0	0	0	0	0	0	0	0	0	0	0	0	0	0	0	0
GREEN	GREEN (000) Dark	0	0	0	0	0	0	0	0	0	0	0	0	0	0	0	0	0	0	0	0	0	0	0	0
	GREEN (001)	0	0	0	0	0	0	0	0	0	0	0	0	0	0	0	1	0	0	0	0	0	0	0	0
	...	...								...								...							
	GREEN (254)	0	0	0	0	0	0	0	0	1	1	1	1	1	1	1	0	0	0	0	0	0	0	0	0
	GREEN (255)	0	0	0	0	0	0	0	0	1	1	1	1	1	1	1	1	0	0	0	0	0	0	0	0
BLUE	BLUE (000) Dark	0	0	0	0	0	0	0	0	0	0	0	0	0	0	0	0	0	0	0	0	0	0	0	0
	BLUE (001)	0	0	0	0	0	0	0	0	0	0	0	0	0	0	0	0	0	0	0	0	0	0	0	1
	...	...								...								...							
	BLUE (254)	0	0	0	0	0	0	0	0	0	0	0	0	0	0	0	0	1	1	1	1	1	1	1	0
	BLUE (255)	0	0	0	0	0	0	0	0	0	0	0	0	0	0	0	0	1	1	1	1	1	1	1	1

Product Specification

### 3-6. Power Sequence

#### 3-6-1. Power Sequence

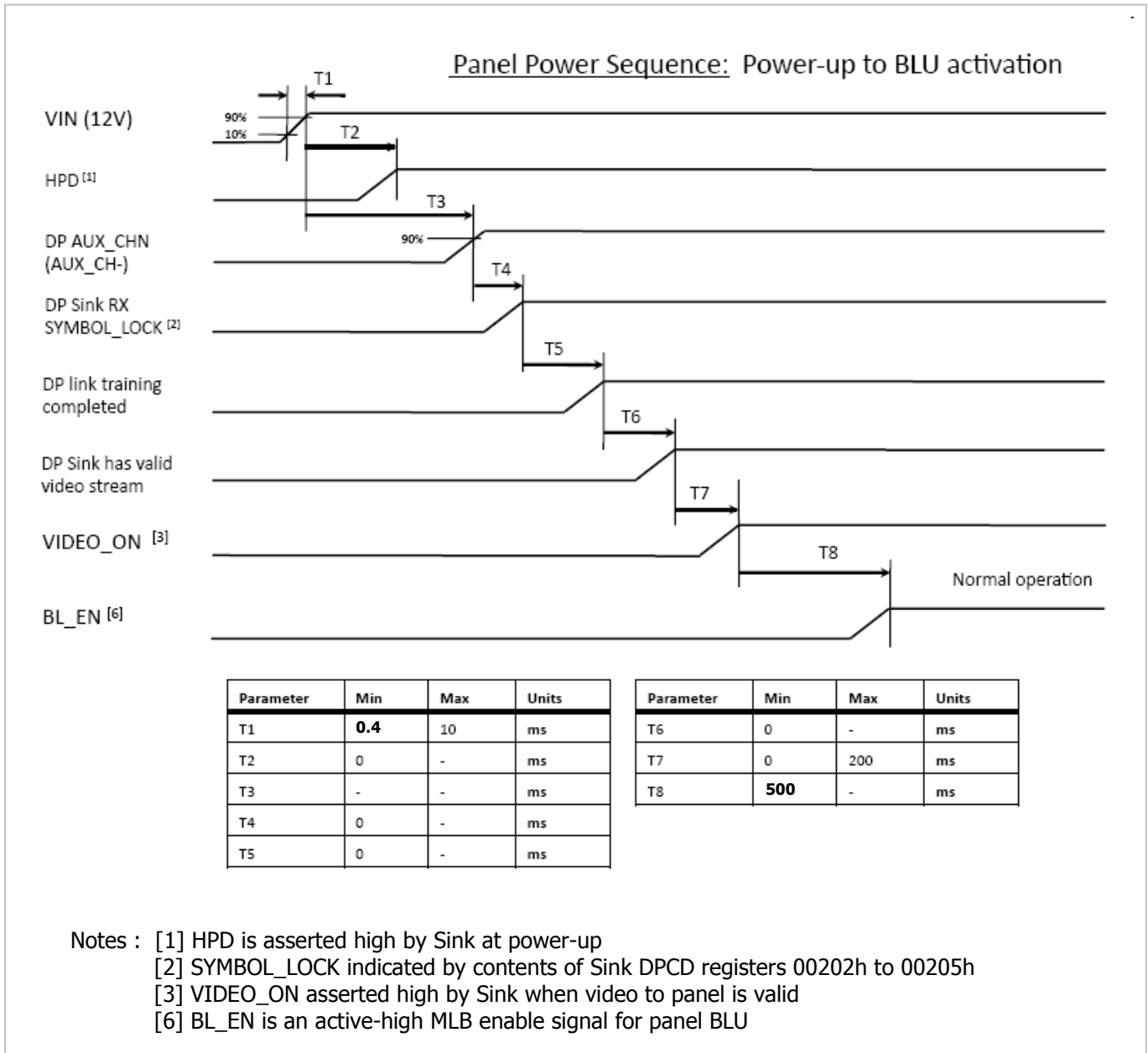

- Notes :
1. Please avoid floating state of interface signal at invalid period.
  2. When the interface signal is invalid, be sure to pull down the power supply for LCD  $V_{LCD}$  to 0V.
  3. LED power must be turn on after power supply for LCD and interface signal are valid.

Product Specification

### 3-6. Power Sequence

#### 3-6-1. Power Sequence

Panel Power Sequence: BLU de-activation, power-down

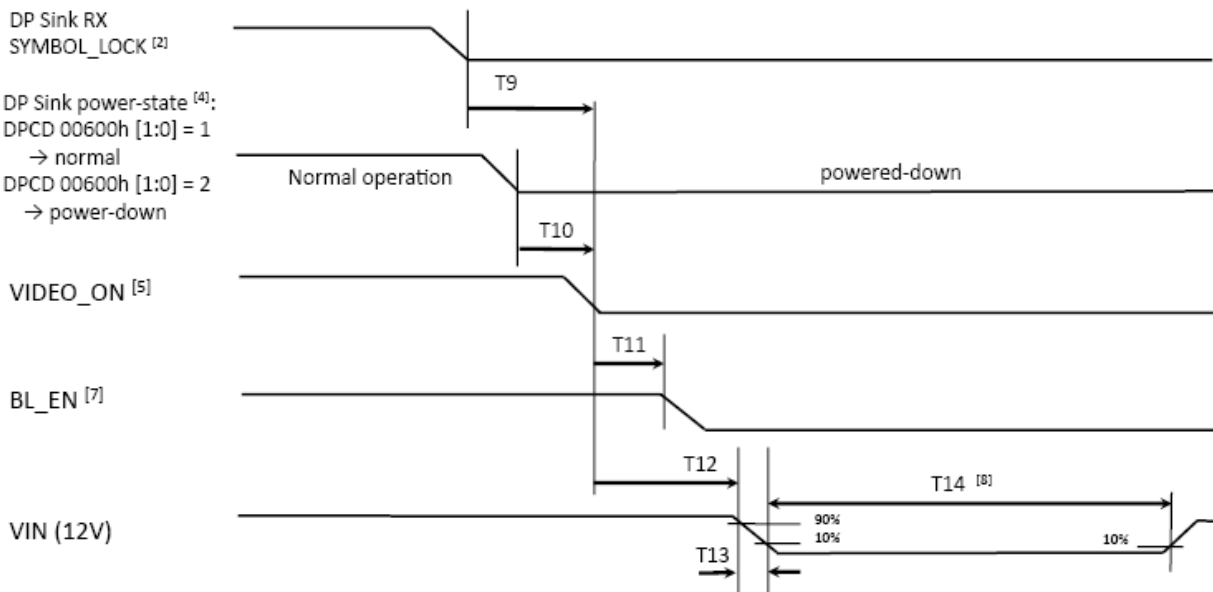

Parameter	Min	Max	Units
T9	0	10	ms
T10	0	5	ms
T11	-	10	ms
T12	0	-	ms
T13	0.01	1000	ms
T14	250	-	ms

- Notes :
- [2] SYMBOL\_LOCK indicated by contents of Sink DPCD registers 00202h to 00205h
  - [4] Power-state set by Source in Sink DPCD register 00600h
  - [5] VIDEO\_ON asserted low by Sink because of :
    - 1) loss of SYMBOL\_LOCK or
    - 2) DP Sink is powered down
  - [7] BL\_EN must be asserted low by system as rapidly as possible when video is invalid to avoid visible artifacts
  - [8] T14 defines minimum off-time for 12V power
  - [9] min. times of 0 indicate precedence ordering of events, e.g. where actual timing is TBD







**Product Specification**

Notes 1. Contrast Ratio(CR) is defined mathematically as :

$$\text{Contrast Ratio} = \frac{\text{Surface Luminance with all white pixels}}{\text{Surface Luminance with all black pixels}}$$

It is measured at center point(Location P1)

2. Surface luminance( $L_{WH}$ ) is luminance value at 5 points average across the LCD surface 50cm from the surface with all pixels displaying white. For more information see FIG 2.

$$L_{WH} = \text{Average}[L_{on1}, L_{on2}, L_{on3}, L_{on4}, L_{on5}]$$

3. The variation in surface luminance,  $\delta_{WHITE}$  is defined as :

$$\delta_{WHITE} = \frac{\text{Maximum}(L_{on1}, L_{on2}, \dots, L_{on13}) - \text{Minimum}(L_{on1}, L_{on2}, \dots, L_{on13})}{\text{Average}(L_{on1}, L_{on2}, \dots, L_{on5})} \times 100(\%)$$

Where L1 to L13 are the luminance with all pixels displaying white at 13 locations.

For more information see FIG 2.

4. Response time is the time required for the display to transition from black to white (Rise Time,  $Tr_R$ ) and from white to black (Decay Time,  $Tr_D$ ). For additional information see FIG 3

5. Color shift is the angle at which the color difference is lower than 0.04.

For more information see FIG 4.

- Color difference ( $\Delta u'v'$ )

$$u' = \frac{4x}{-2x + 12y + 3} \quad v' = \frac{9y}{-2x + 12y + 3}$$

$$\Delta u'v' = \sqrt{(u'_1 - u'_2)^2 + (v'_1 - v'_2)^2} \quad \begin{array}{l} u'_1, v'_1 : u'v' \text{ value at viewing angle direction} \\ u'_2, v'_2 : u'v' \text{ value at front } (\theta=0) \end{array}$$

- Pattern size : 25% Box size

- Viewing angle direction of color shift : Horizontal, Vertical

6. Viewing angle is the angle at which the contrast ratio is greater than 10. The angles are determined for the horizontal or x axis and the vertical or y axis with respect to the z axis which is normal to the LCD surface. For more information see FIG 5.

7. Effective viewing angle is the angle at which the gamma shift of gray scale is lower than 0.3.

For more information see FIG 6 and FIG 7.

8. Gray scale specification

Gamma Value is approximately 2.2. For more information see Table 10.









**Product Specification**
**Table 10. Gray Scale Specification**

Gray Level	Relative Luminance [%] (Typ.)
0	0.10
31	1.08
63	4.71
95	11.5
127	21.7
159	35.5
191	53.1
223	74.5
255	100

LGD\_BSK\_120508

**Product Specification**
**5. Mechanical Characteristics**

The contents provide general mechanical characteristics. In addition the figures in the next page are detailed mechanical drawing of the LCD.

Outline Dimension	Horizontal	630.0mm
	Vertical	376.13mm
	Depth	21.8mm
Bezel Area	Horizontal	601.7mm
	Vertical	340.7mm
Active Display Area	Horizontal	596.74mm
	Vertical	335.66mm
Weight	4,600g (Typ.)	
Surface Treatment	Hard coating(2H) Glare, Low Reflection treatment of the front polarizer	

Notes : Please refer to a mechanic drawing in terms of tolerance at the next page.





**Product Specification**
**6. Reliability**

Environment test condition

No	Test Item	Condition
1	High temperature storage test	Ta= 60°C 240h
2	Low temperature storage test	Ta= -20°C 240h
3	High temperature operation test	Ta= 50°C 50%RH 240h
4	Low temperature operation test	Ta= 0°C 240h
5	Vibration test (non-operating)	Wave form : random Vibration level : 1.0G RMS Bandwidth : 10-300Hz Duration : X,Y,Z, 10 min One time each direction
6	Shock test (non-operating)	Shock level : 100Grms Waveform : half sine wave, 2ms Direction : ± X, ± Y, ± Z One time each direction
7	Altitude Operating Storage / Shipment	0 - 10,000 feet(3,048m) 0 - 40,000 feet(12,192m)



## 7. International Standards

### 7-1. Safety

- a) UL 60950-1, Second Edition, Underwriters Laboratories Inc.  
Information Technology Equipment - Safety - Part 1 : General Requirements.
- b) CAN/CSA C22.2 No.60950-1-07, Second Edition, Canadian Standards Association.  
Information Technology Equipment - Safety - Part 1 : General Requirements.
- c) EN 60950-1:2006 + A11:2009, European Committee for Electrotechnical Standardization(CENELEC).  
Information Technology Equipment - Safety - Part 1 : General Requirements.
- d) IEC 60950-1:2005, Second Edition, The International Electrotechnical Commission (IEC).  
Information Technology Equipment - Safety - Part 1 : General Requirements.  
(Including report of IEC60825-1:2001 clause 8 and clause 9)

#### Notes

- 1. Laser (LED Backlight) Information

Class 1M LED Product IEC60825-1 : 2001 Embedded LED Power (Class 1M)
--

- 2. Caution  
: LED inside.  
Class 1M laser (LEDs) radiation when open.  
Do not open while operating.

### 7-2. EMC

- a) ANSI C63.4 "American National Standard for Methods of Measurement of Radio-Noise Emissions from Low-Voltage Electrical and Electronic Equipment in the Range of 9 kHz to 40 GHz." American National Standards Institute (ANSI), 2003.
- b) CISPR 22 "Information technology equipment – Radio disturbance characteristics – Limit and methods of measurement." International Special Committee on Radio Interference (CISPR), 2005.
- c) CISPR 13 "Sound and television broadcast receivers and associated equipment – Radio disturbance characteristics – Limits and method of measurement." International Special Committee on Radio Interference (CISPR), 2006.

### 7-3. Environment

- a) RoHS, Directive 2002/95/EC of the European Parliament and of the council of 27 January 2003

Product Specification

## 8. Packing

### 8-1. Designation of Lot Mark

a) Lot Mark



A,B,C : SIZE(INCH)  
E : MONTH

D : YEAR  
F ~ M : SERIAL NO.

Note

1. YEAR

Year	2001	2002	2003	2004	2005	2006	2007	2008	2009	2010
Mark	1	2	3	4	5	6	7	8	9	0

2. MONTH

Month	Jan	Feb	Mar	Apr	May	Jun	Jul	Aug	Sep	Oct	Nov	Dec
Mark	1	2	3	4	5	6	7	8	9	A	B	C

b) Location of Lot Mark

Serial No. is printed on the label. The label is attached to the backside of the LCD module.  
This is subject to change without prior notice.

### 8-2. Packing Form

a) Package quantity in one box : 7ea

b) Box Size : 747mm X 335mm X 466mm

**Product Specification****9. PRECAUTIONS**

Please pay attention to the followings when you use this TFT LCD module.

**9-1. MOUNTING PRECAUTIONS**

- (1) You must mount a module using holes arranged in four corners or four sides.
- (2) You should consider the mounting structure so that uneven force (ex. Twisted stress) is not applied to the module. And the case on which a module is mounted should have sufficient strength so that external force is not transmitted directly to the module.
- (3) Please attach the surface transparent protective plate to the surface in order to protect the polarizer. Transparent protective plate should have sufficient strength in order to resist external force.
- (4) You should adopt radiation structure to satisfy the temperature specification.
- (5) Acetic acid type and chlorine type materials for the cover case are not desirable because the former generates corrosive gas of attacking the polarizer at high temperature and the latter causes circuit break by electro-chemical reaction.
- (6) Do not touch, push or rub the exposed polarizers with glass, tweezers or anything harder than HB pencil lead. And please do not rub with dust clothes with chemical treatment. Do not touch the surface of polarizer for bare hand or greasy cloth. (Some cosmetics are detrimental to the polarizer.)
- (7) When the surface becomes dusty, please wipe gently with absorbent cotton or other soft materials like chamois soaks with petroleum benzene. Normal-hexane is recommended for cleaning the adhesives used to attach front / rear polarizers. Do not use acetone, toluene and alcohol because they cause chemical damage to the polarizer.
- (8) Wipe off saliva or water drops as soon as possible. Their long time contact with polarizer causes deformations and color fading.
- (9) Do not open the case because inside circuits do not have sufficient strength.

**9-2. OPERATING PRECAUTIONS**

- (1) The spike noise causes the miss-operation of circuits. It should be lower than following voltage :  
 $V = \pm 200\text{mV}$  (Over and under shoot voltage)
- (2) Response time depends on the temperature. (In lower temperature, it becomes longer.)
- (3) Brightness depends on the temperature. (In higher temperature, it becomes lower.)  
And in lower temperature, response time (required time that brightness is stable after turned on) becomes longer.
- (4) Be careful for condensation at sudden temperature change. Condensation makes damage to polarizer or electrical contacted parts. And after fading condensation, smear or spot will occur.
- (5) When fixed patterns are displayed for a long time, remnant image is likely to occur.
- (6) Module has high frequency circuits. Sufficient suppression to the electromagnetic interference shall be done by system manufacturers. Grounding and shielding methods may be important to minimized the interference.
- (7) Please do not give any mechanical and/or acoustical impact to LCM. Otherwise, LCM can't be operated its full characteristics perfectly.
- (8) A screw which is fastened up the steels should be a machine screw.  
(if not, it causes metallic foreign material and deal LCM a fatal blow)
- (9) Please do not set LCD on its edge.
- (10) Partial darkness may happen during 3~5 minutes when LCM is operated initially in condition that luminance is under 40% at low temperature (under 5°C). This phenomenon which disappears naturally after 3~5 minutes is not a problem about reliability but LCD characteristic

### **9-3. ELECTROSTATIC DISCHARGE CONTROL**

Since a module is composed of electronic circuits, it is not strong to electrostatic discharge. Make certain that treatment persons are connected to ground through wrist band etc. And don't touch interface pin directly.

### **9-4. PRECAUTIONS FOR STRONG LIGHT EXPOSURE**

Strong light exposure causes degradation of polarizer and color filter.

### **9-5. STORAGE**

When storing modules as spares for a long time, the following precautions are necessary.

- (1) Store them in a dark place. Do not expose the module to sunlight or fluorescent light. Keep the temperature between 5°C and 35°C at normal humidity.
- (2) The polarizer surface should not come in contact with any other object.  
It is recommended that they be stored in the container in which they were shipped.

### **9-6. HANDLING PRECAUTIONS FOR PROTECTION FILM**

- (1) The protection film is attached to the bezel with a small masking tape.  
When the protection film is peeled off, static electricity is generated between the film and polarizer.  
This should be peeled off slowly and carefully by people who are electrically grounded and with well ion-blown equipment or in such a condition, etc.
- (2) When the module with protection film attached is stored for a long time, sometimes there remains a very small amount of glue still on the bezel after the protection film is peeled off.
- (3) You can remove the glue easily. When the glue remains on the bezel surface or its vestige is recognized, please wipe them off with absorbent cotton waste or other soft material like chamois soaked with normal-hexane.

**Product Specification**

**10. EDID DATA**

**10-1. EDID Data**

LM270WQ1-SDE3 EDID DATA (2560X1440 @ 60Hz )						Modified : 2010.11.15
Byte# (decimal)	Byte# (HEX)	Field Name and Comments	Value (HEX)	Value (binary)	Value (DEC)	
0	00	Header	00	00000000	0	Header
1	01	Header	FF	11111111	255	
2	02	Header	FF	11111111	255	
3	03	Header	FF	11111111	255	
4	04	Header	FF	11111111	255	
5	05	Header	FF	11111111	255	
6	06	Header	FF	11111111	255	
7	07	Header	00	00000000	0	
8	08	EISA manufacture code ( 3 Character ID )	APP	06	00000110	6
9	09	EISA manufacture code (Compressed ASC II)		10	00010000	16
10	0A	Panel Supplier Reserved - Product Code	A007h	07	00000111	7
11	0B	( Hex. LSB first )	A0	10100000	160	product ID for LM270WQ1-SDE3 =
12	0C	32-bit serial #		00	00000000	0
13	0D			00	00000000	0
14	0E			00	00000000	0
15	0F			00	00000000	0
16	10	Week of Manufacture	2D	00101101	45	0xA007 Vendor/ Product ID
17	11	Year of Manufacture	2010 years	14	00010100	
18	12	EDID structure version # = 1		01	00000001	1
19	13	EDID revision # = 4		04	00000100	4
20	14	Video input Definition = DisplayPort 10bit		B5	10110101	181
21	15	Max H image size (Rounded cm) = 60 cm		3C	00111100	60
22	16	Max V image size (Rounded cm) = 34 cm		22	00100010	34
23	17	Display gamma = (gamma*100)-100 = Example:(2.2*100)-100=		78	01111000	120
24	18	Feature Support [ Display Power Management(DPM) : No standby/No suspend, Active Off/Very Low Power., Display Color Type : Monochrome of Grayscale display., Other Feature Support Flags : No sRGB, Preferred Timing Mode, No Display is continuous frequency (Multi-mode Base EDID and Extension Block).]		22	00100010	34
25	19	Red/Green Low Bits (RxRy/GxGy)		6F	01101111	111
26	1A	Blue/White Low Bits (BxBy/WxWy)		B1	10110001	177
27	1B	Red X Rx = 0.653		A7	10100111	167
28	1C	Red Y Ry = 0.334		55	01010101	85
29	1D	Green X Gx = 0.30		4C	01001100	76
30	1E	Green Y Gy = 0.620		9E	10011110	158
31	1F	Blue X Bx = 0.146		25	00100101	37
32	20	Blue Y By = 0.050		0C	00001100	12
33	21	White X Wx = 0.313		50	01010000	80
34	22	White Y Wy = 0.329		54	01010100	84
35	23	Established timing 1 (00h if not used)		00	00000000	0
36	24	Established timing 2 (00h if not used)		00	00000000	0
37	25	Manufacturer's timings		00	00000000	0
38	26	Standard timing ID1 (01h if not used)		01	00000001	1
39	27	Standard timing ID1 (01h if not used)		01	00000001	1
40	28	Standard timing ID2 (01h if not used)		01	00000001	1
41	29	Standard timing ID2 (01h if not used)		01	00000001	1
42	2A	Standard timing ID3 (01h if not used)		01	00000001	1
43	2B	Standard timing ID3 (01h if not used)		01	00000001	1
44	2C	Standard timing ID4 (01h if not used)		01	00000001	1
45	2D	Standard timing ID4 (01h if not used)		01	00000001	1
46	2E	Standard timing ID5 (01h if not used)		01	00000001	1
47	2F	Standard timing ID5 (01h if not used)		01	00000001	1
48	30	Standard timing ID6 (01h if not used)		01	00000001	1
49	31	Standard timing ID6 (01h if not used)		01	00000001	1
50	32	Standard timing ID7 (01h if not used)		01	00000001	1
51	33	Standard timing ID7 (01h if not used)		01	00000001	1
52	34	Standard timing ID8 (01h if not used)		01	00000001	1
53	35	Standard timing ID8 (01h if not used)		01	00000001	1
54	36	Detailed timing/monitor		56	01010110	86
55	37	Pixel Clock = 241.5 MHz		5E	01011110	94
56	38	Hor active= 2560 pixels		00	00000000	0
57	39	Hor blanking= 160 pixels		A0	10100000	160
58	3A			A0	10100000	160
59	3B	Vertical active= 1440 lines		A0	10100000	160
60	3C	Vertical blanking= 41 lines		29	00101001	41
61	3D			50	01010000	80
62	3E	H sync. Offset= 48 pixels		30	00110000	48
63	3F	H sync. Width= 32 pixels		20	00100000	32
64	40	V sync. Offset=3 lines		35	00110101	53
65	41	V sync. Width= 5 lines		00	00000000	0
66	42	H image size= 597 mm		55	01010101	85
67	43	V image size = 336 mm		50	01010000	80
68	44			21	00100001	33
69	45	No Horizontal Border		00	00000000	0
70	46	No Vertical Border		00	00000000	0
71	47	Non-Interface, Normal display, no stereo, Digital Separate [ Vsync, NEG, Hsync, POS		1A	00011010	26

**Product Specification**

72	48	1280x720p Timing	1A	00011010	26	
73	49	Pixel Clock = 74.5 MHz	1D	00011101	29	
74	4A	Horizontal Active = 1280 Pixels	00	00000000	0	
75	4B	Horizontal Blanking = 384 Pixels	80	10000000	128	
76	4C		51	01010001	81	
77	4D	Vertical Active = 720 Lines	D0	11010000	208	
78	4E	Vertical Blanking = 28 Lines	1C	00011100	28	
79	4F		20	00100000	32	Detailed Timing Description #2
80	50	Horizontal Sync. Offset = 64 Pixels	40	01000000	64	
81	51	Horizontal Sync Pulse Width = 128 Pixels	80	10000000	128	
82	52	V sync. Offset=3 lines	35	00110101	53	
83	53	V sync. Width= 5 lines	00	00000000	0	
84	54	H image size= 597 mm	55	01010101	85	
85	55	V image size = 336 mm	50	01010000	80	
86	56		21	00100001	33	
87	57	No Horizontal Border	00	00000000	0	
88	58	No Vertical Border	00	00000000	0	
89	59	Non-Interface, Normal display, no stereo, Digital Separate [ Vsync, NEG, Hsync, POS (a	1C	00011100	28	
90	5A	Detailed timing/monitor descriptor #3	00	00000000	0	
91	5B		00	00000000	0	
92	5C		00	00000000	0	
93	5D		FC	11111100	252	
94	5E		00	00000000	0	
95	5F		69	01101001	105	
96	60		4D	01001101	77	
97	61		61	01100001	97	Detailed Timing Description #3
98	62		63	01100011	99	
99	63		0A	00001010	10	
100	64		20	00100000	32	
101	65		20	00100000	32	Ascii Data String: LM270WQ1-SDA2
102	66		20	00100000	32	
103	67		20	00100000	32	
104	68		20	00100000	32	
105	69		20	00100000	32	
106	6A		20	00100000	32	
107	6B		20	00100000	32	
108	6C	Detailed timing/monitor descriptor #4	00	00000000	0	
109	6D		00	00000000	0	
110	6E	Color LCD	00	00000000	0	
111	6F		00	00000000	0	
112	70		00	00000000	0	
113	71		00	00000000	0	
114	72		00	00000000	0	
115	73		00	00000000	0	Detailed Timing Description #4
116	74		00	00000000	0	
117	75		00	00000000	0	
118	76		00	00000000	0	
119	77		00	00000000	0	Monitor Name: Color LCD
120	78		00	00000000	0	
121	79		00	00000000	0	
122	7A		00	00000000	0	
123	7B		00	00000000	0	
124	7C		00	00000000	0	
125	7D		00	00000000	0	
126	7E	Extension Flag = 01	01	00000001	1	Extension Flag
127	7F	<b>Checksum</b>	<b>8D</b>	<b>10001101</b>	<b>141</b>	<b>Checksum</b>
128	80	Tag	02	00000010	2	
129	81	Revision Number	03	00000011	3	
130	82	Offset of first Detailed Timing Description	0C	00001100	12	
131	83	Device Support & No. of Native Formats	C1	11000001	193	
132	84	Audio Data Block Tag	23	00100011	35	
133	85	CEA Short Video Descriptor 1	09	00001001	9	
134	86	Audio Data Block Tag	07	00000111	7	
135	87	CEA Short Audio Descriptor 1	07	00000111	7	
136	88	Speaker Allocation Data Block Tag	83	10000011	131	
137	89		01	00000001	1	
138	8A	Speaker Allocation Payload	00	00000000	0	
139	8B		00	00000000	0	
140	8C	Detailed timing/monitor	56	01010110	86	
141	8D	Pixel Clock = 241.5 MHz	5E	01011110	94	
142	8E	Hor active= 2560 pixels	00	00000000	0	
143	8F	Hor blanking= 160 pixels	A0	10100000	160	
144	90		A0	10100000	160	
145	91	Vertical active= 1440 lines	A0	10100000	160	
146	92	Vertical blanking= 41 lines	29	00101001	41	

**Product Specification**

147	93		50	01010000	80
148	94	H sync. Offset= 48 pixels	30	00110000	48
149	95	H sync. Width= 32 pixels	20	00100000	32
150	96	V sync. Offset= 3 lines	35	00110101	53
151	97	V sync. Width= 5 lines	00	00000000	0
152	98	H image size= 597 mm	55	01010101	85
153	99	V image size = 336 mm	50	01010000	80
154	9A		21	00100001	33
155	9B	No Horizontal Border	00	00000000	0
156	9C	No Vertical Border	00	00000000	0
157	9D	Non-interlaced, Normal display, No stereo, Digital separate sync, HV pos Negatives	1A	00011010	26
158	9E	1280x720p Timing	1A	00011010	26
159	9F	Pixel Clock = 74.5 MHz	1D	00011101	29
160	A0	Horizontal Active = 1280 Pixels	00	00000000	0
161	A1	Horizontal Blanking = 384 Pixels	80	10000000	128
162	A2		51	01010001	81
163	A3	Vertical Active = 720 Lines	D0	11010000	208
164	A4	Vertical Blanking = 28 Lines	1C	00011100	28
165	A5		20	00100000	32
166	A6	Horizontal Sync. Offset = 64 Pixels	40	01000000	64
167	A7	Horizontal Sync Pulse Width = 128 Pixels	80	10000000	128
168	A8	V sync. Offset=3 lines	35	00110101	53
169	A9	V sync. Width= 5 lines	00	00000000	0
170	AA	H image size= 597 mm	55	01010101	85
171	AB	V image size = 336 mm	50	01010000	80
172	AC		21	00100001	33
173	AD	No Horizontal Border	00	00000000	0
174	AE	No Vertical Border	00	00000000	0
175	AF	Normal display, no stereo, Digital Separate ( Vsync_POS, Hsync_POS)	1C	00011100	28
176	B0	Pixel Clock = 127.75 MHz	E7	11100111	231
177	B1	Horizontal Active = 1280 pixels	31	00110001	49
178	B2	Horizontal Blanking = 160 pixels	00	00000000	0
179	B3	Vertical Active = 1440 lines	A0	10100000	160
180	B4	Vertical Blanking = 41 lines	50	01010000	80
181	B5	Horizontal Sync Offset (Front Porch) = 48 Pixels (from blanking)	A0	10100000	160
182	B6	Horizontal Sync Pulse Width = 32 Pixels	29	00101001	41
183	B7	Vertical Sync Offset = 3 lines	50	01010000	80
184	B8	Vertical Sync Pulse Width = 10 lines	30	00110000	48
185	B9	Horizontal Image Size = 597 mm	20	00100000	32
186	BA	Vertical Image Size = 336 mm	3A	00111010	58
187	BB	Horizontal Border = 0 Pixels	00	00000000	0
188	BC	Vertical Border = 0 Lines	55	01010101	85
189	BD	Vertical Border = 0 Lines	50	01010000	80
190	BE		21	00100001	33
191	BF	Calculated Horizontal Refresh = 0.89 kHz	00	00000000	0
192	C0	Calculated Vertical Refresh = 0.60 Hz	00	00000000	0
193	C1		1A	00011010	26
194	C2		00	00000000	0
195	C3		00	00000000	0
196	C4		00	00000000	0
197	C5		00	00000000	0
198	C6		00	00000000	0
199	C7		00	00000000	0
200	C8		00	00000000	0
201	C9		00	00000000	0
202	CA		00	00000000	0
203	CB		00	00000000	0
204	CC		00	00000000	0
205	CD		00	00000000	0
206	CE		00	00000000	0
207	CF		00	00000000	0
208	D0		00	00000000	0
209	D1		00	00000000	0
210	D2		00	00000000	0
211	D3		00	00000000	0
212	D4		00	00000000	0
213	D5		00	00000000	0
214	D6		00	00000000	0
215	D7		00	00000000	0
216	D8		00	00000000	0
217	D9		00	00000000	0
218	DA		00	00000000	0
219	DB		00	00000000	0
220	DC		00	00000000	0
221	DD		00	00000000	0
222	DE		00	00000000	0
223	DF		00	00000000	0
224	E0		00	00000000	0
225	E1		00	00000000	0

Product Specification

226	E2	00	00000000	0
227	E3	00	00000000	0
228	E4	00	00000000	0
229	E5	00	00000000	0
230	E6	00	00000000	0
231	E7	00	00000000	0
232	E8	00	00000000	0
233	E9	00	00000000	0
234	EA	00	00000000	0
235	EB	00	00000000	0
236	EC	00	00000000	0
237	ED	00	00000000	0
238	EE	00	00000000	0
239	EF	00	00000000	0
240	F0	00	00000000	0
241	F1	00	00000000	0
242	F2	00	00000000	0
243	F3	00	00000000	0
244	F4	00	00000000	0
245	F5	00	00000000	0
246	F6	00	00000000	0
247	F7	00	00000000	0
248	F8	00	00000000	0
249	F9	00	00000000	0
250	FA	00	00000000	0
251	FB	00	00000000	0
252	FC	00	00000000	0
253	FD	00	00000000	0
254	FE	00	00000000	0
255	FF	Checksum	8B 10001000	

## 10-2. EDID DATA READ/WRITE PROTOCOL

### 10-2-1. READ Operation

<Start><Slave Address, RW=0><Byte Address><Start><Slave Address, RW=1><Data><Stop>

### 10-2-2. WRITE Operation

<Start><Slave Address, RW=0><Byte Address><Data><Stop>

- **Device Address** (Slave Address)

Type	Device (Slave) Address								Hex
IS24C02B	1	0	1	0	0	0	0	RW	0xA0 + RW

- **Byte Address**

Byte Address	
Decimal	0 ~ 127
Hex	0x00 ~ 0x7F