



SOLUTIONS

DISPLAYS | TOUCH | EMBEDDED

TFT-Display Datasheet

LM238WR3-SSB1 | LG Display

Features

| | |
|-------------------------|-----------------------|
| ■ Active Screen Area | 525.66x295.7 [mm] |
| ■ Size Format | 23,8" 16:9 |
| ■ Resolution | 3840x2160 |
| ■ Backlight | LED |
| ■ Brightness | 350 cd/m ² |
| ■ LED Life Time | 30K (h) |
| ■ Interface | eDP |
| ■ Viewing Angle | L/R 89/89 - U/D 89/89 |
| ■ Touchscreen | no |
| ■ Power Supply | 10.0V [Typ.] |
| ■ Module Outline | 536.3x313.9x12.9 [mm] |
| ■ Operation Temperature | -0... + 50°C |
| ■ Storage Temperature | -20... + 60°C |

Contact

HY-LINE Computer Components
Vertriebs GmbH
Inselkammerstr. 10
82008 Unterhaching
Germany

Support

Tel.: +49 89 614 503 40
Fax. +49 89 614 503 50

Send us an email
computer@hy-line.de

Product Specification

SPECIFICATION FOR APPROVAL

(●) Preliminary Specification
() Final Specification

| | |
|-------|-------------------|
| Title | 23.8" UHD TFT LCD |
|-------|-------------------|

| | |
|-------|---------|
| BUYER | GENERAL |
| MODEL | |

| | |
|----------|----------------------|
| SUPPLIER | LG Display Co., Ltd. |
| *MODEL | LM238WR3 |
| SUFFIX | SSB1 |

*When you obtain standard approval, please use the above model name without suffix

| APPROVED BY | SIGNATURE DATE |
|-------------|----------------|
| / | _____ |
| / | _____ |
| / | _____ |

Please return 1 copy for your confirmation with your signature and comments.

| APPROVED BY | SIGNATURE DATE |
|-------------------------|----------------|
| W.G. Kweon / G.Manager | _____ |
| REVIEWED BY | |
| K.H. Hwang/ Manager [C] | _____ |
| S.Y. An / Manager [M] | _____ |
| G.S. Kim / Manager [O] | _____ |
| T.H. Shin / Manager [P] | _____ |
| PREPARED BY | |
| S.Y. Kim / Engineer | _____ |

Product Engineering Dept.
LG Display Co., Ltd

Product Specification
Contents

| No | ITEM | Page |
|-----|---|------|
| | COVER | 1 |
| | CONTENTS | 2 |
| | RECORD OF REVISIONS | 3 |
| 1 | GENERAL DESCRIPTION | 4 |
| 2 | ABSOLUTE MAXIMUM RATINGS | 5 |
| 3 | ELECTRICAL SPECIFICATIONS | 6 |
| 3-1 | ELECTRICAL CHARACTERISTICS | 6 |
| 3-2 | INTERFACE CONNECTIONS | 9 |
| 3-3 | eDP SIGNAL SPECIFICATIONS | 11 |
| 3-4 | SIGNAL TIMING SPECIFICATIONS | 15 |
| 3-5 | SIGNAL TIMING WAVEFORMS | 16 |
| 3-6 | COLOR INPUT DATA REFERNECE | 17 |
| 3-7 | POWER SEQUENCE & DIP CONDITION FOR LCD MODULE | 18 |
| 4 | OPTICAL SPECIFICATIONS | 20 |
| 5 | MECHANICAL CHARACTERISTICS | 26 |
| 6 | RELIABILITY | 29 |
| 7 | INTERNATIONAL STANDARDS | 30 |
| 7-1 | SAFETY | 30 |
| 7-2 | ENVIRONMENT | 30 |
| 8 | PACKING | 31 |
| 8-1 | DESIGNATION OF LOT MARK | 31 |
| 8-2 | PACKING FORM | 31 |
| 9 | PRECAUTIONS | 32 |
| 9-1 | MOUNTING PRECAUTIONS | 32 |
| 9-2 | OPERATING PRECAUTIONS | 32 |
| 9-3 | ELECTROSTATIC DISCHARGE CONTROL | 33 |
| 9-4 | PRECAUTIONS FOR STRONG LIGHT EXPOSURE | 33 |
| 9-5 | STORAGE | 33 |
| 9-6 | HANDLING PRECAUTIONS FOR PROTECTION FILM | 33 |

Product Specification

1. General Description

LM238WR3 is a Color Active Matrix Liquid Crystal Display with a Light Emitting Diode (LED) backlight Assembly without LED driver. The matrix employs a-Si Thin Film Transistor as the active element. It is a transmissive type display operating in the normally black mode. It has a 23.8 inch diagonally measured active display area with UHD resolution (3840 horizontal by 2160 vertical pixel array) Each pixel is divided into Red, Green and Blue sub-pixels or dots which are arranged in vertical stripes. Gray scale or the brightness of the sub-pixel color is determined with a 10-bit gray scale signal for each dot, thus, presenting a palette of more than 1.07Billion colors with A-FRC (Advanced Frame Rate Control). It has been designed to apply eDP interface. It is intended to support displays where high brightness, super wide viewing angle, high color saturation, and high color are important.

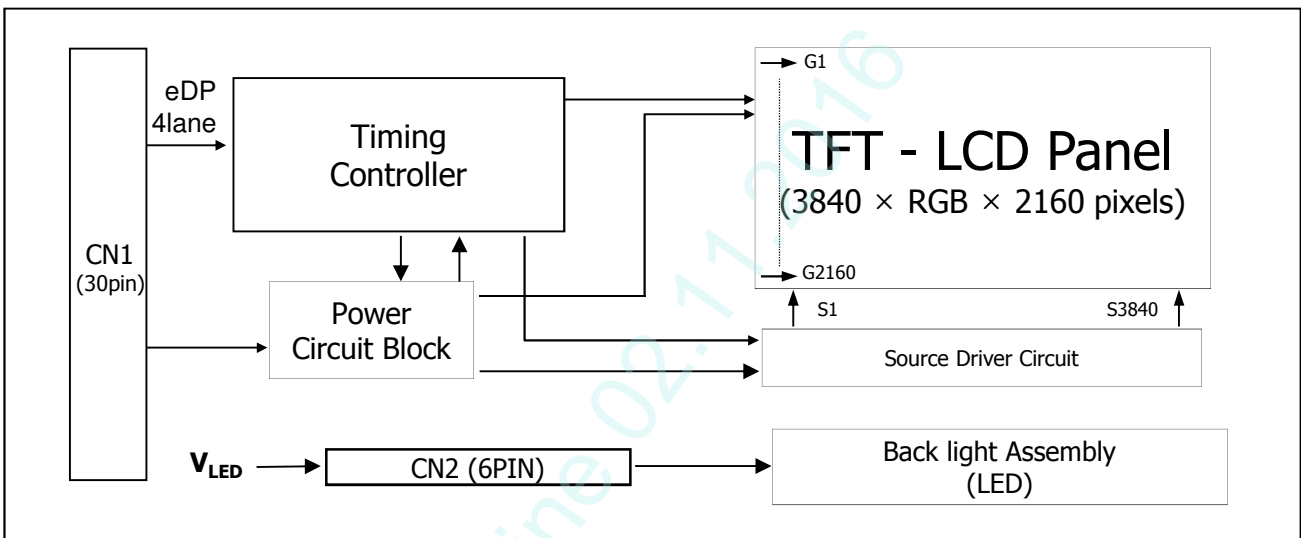

[FIG.1] Block diagram

General Features

| | |
|------------------------|---|
| Active Screen Size | 23.8 inches(60.31cm) (Aspect ratio 16:9) |
| Outline Dimension | 536.3(H) x 313.9(V) x 12.9(D) mm (Typ.) |
| Pixel Pitch | 0.13690 mm x 0.13690 mm |
| Pixel Format | 3840 horiz. By 2160 vert. Pixels RGB stripes arrangement |
| Color Depth | 1.07 Billion colors, 10Bit (8Bit + A-FRC) |
| Luminance, White | 350 cd/m ² (Center 1 Point, Typ.) |
| Viewing Angle(CR>10) | View Angle Free (R/L 178(Typ.), U/D 178(Typ.)) |
| Power Consumption | Total 25.7 Watt (6.3 Watt @VLCD 19.4 Watt @Is=120mA) |
| Weight | Typ : 1610g, Max : 1690g |
| Display Operating Mode | Transmissive mode, normally black |
| Panel type | Reverse type |
| Concept | 3-side borderless |
| Surface Treatment | Advanced Anti-glare treatment of the front polarizer (3H) |

Product Specification

2. Absolute Maximum Ratings

The following are maximum values which, if exceeded, may cause faulty operation or damage to the unit.

Table 1. ABSOLUTE MAXIMUM RATINGS

| Parameter | Symbol | Values | | Units | Notes |
|----------------------------|--------|--------|-----|-------|-------------|
| | | Min | Max | | |
| Power Input Voltage | VLCD | -0.3 | 12 | Vdc | at 25 ± 2°C |
| Operating Temperature | TOP | 0 | 50 | °C | 1, 2, 3 |
| Storage Temperature | TST | -20 | 60 | °C | |
| Operating Ambient Humidity | HOP | 10 | 90 | %RH | |
| Storage Humidity | HST | 10 | 90 | %RH | |

- Note : 1. Temperature and relative humidity range are shown in the figure below.
 Wet bulb temperature should be 39 °C Max, and no condensation of water.
 2. Maximum Storage Humidity is up to 40°C, 70% RH only for 4 corner light leakage Mura.
 3. Storage condition is guaranteed under packing condition
 4. LCM Surface Temperature should be Min. 0°C and Max. 65°C under the VLCD=10V, fV=60Hz, 25°C ambient Temp. no humidity control and LED string current is typical value.

FIG.2 Temperature and relative humidity

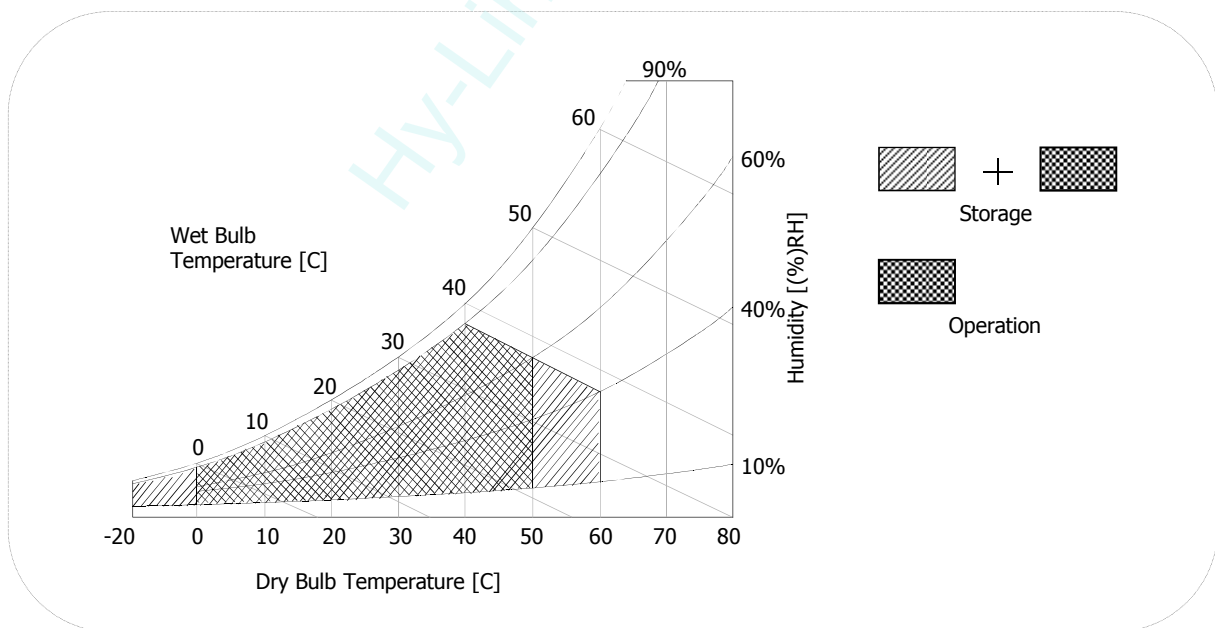

Product Specification
3. Electrical Specifications
3-1. Electrical Characteristics

It requires two power inputs. One is employed to power the LCD electronics and to drive the TFT array and liquid crystal. The second input power for the LED/Backlight, is typically generated by a LED Driver. The LED Driver is an external unit to the LCDs.

Table 2-1. ELECTRICAL CHARACTERISTICS

| Parameter | Symbol | Values | | | Unit | Notes |
|-------------------------------|---------------------|--------|------|------|-------------------|-------|
| | | Min | Typ | Max | | |
| MODULE : | | | | | | |
| Power Supply Input Voltage | V _{LCD} | 9.5 | 10.0 | 10.5 | Vdc | 5 |
| Permissive Power Input Ripple | V _{ripple} | | | 400 | mV _{p-p} | 1 |
| Power Supply Input Current | I _{LCD} | - | 630 | 788 | mA | 2 |
| | | - | 840 | 1050 | mA | 3 |
| Power Consumption | P _c TYP | - | 6.3 | 7.88 | Watt | 2 |
| | P _c MAX | - | 8.4 | 10.5 | Watt | 3 |
| Rush current | I _{RUSH} | - | | 3 | A | 4 |

Note :

1. Permissive power ripple should be measured under V_{LCD}=10.0V, 25°C, f_V=60Hz condition and at that time, we recommend the bandwidth configuration of oscilloscope is to be under 20Mhz.
2. The specified current and power consumption are under the V_{LCD}=10.0V, 25°C, f_V=60Hz condition whereas mosaic pattern(8 x 6) is displayed and f_V is the frame frequency.
3. The current is specified at the maximum current pattern.
4. Maximum Condition of Inrush current :
The duration of rush current is about 2ms and rising time of power Input is 1ms(min.).
5. V_{LCD} level must be measured at two points on LCM PCB - between V_{LCD} (test point) and LCM Ground. The measured results need to meet the Power supply input voltage specification.
(Test condition : maximum power pattern , 25°C, fV=60Hz)

Product Specification

- **Permissive Power input ripple** ($V_{LCD} = 10.0V$, $25^{\circ}C$, f_v (frame frequency)=MAX condition)

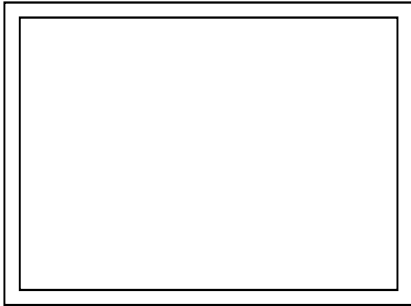

White pattern



Black pattern

- **Power consumption** ($V_{LCD} = 10V$, $25^{\circ}C$, f_v (frame frequency)=60Hz condition)

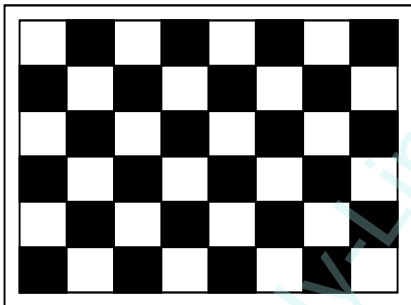

Typical power Pattern

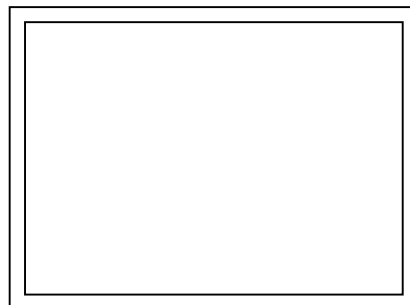

Maximum power Pattern

FIG.3 Mosaic pattern & White Pattern for power consumption measurement

Product Specification
Table 2-2. ELECTRICAL CHARACTERISTICS of LED bar

| Parameter | Symbol | Values | | | Unit | Notes |
|--------------------|--------|--------|--------|--------|------|---------|
| | | Min. | Typ. | Max. | | |
| LED String Current | Is | - | (120) | (125) | mA | 1, 2, 5 |
| LED String Voltage | Vs | (50.3) | (54.0) | (57.6) | V | 1, 5 |
| Power Consumption | PBar | - | (19.4) | (20.8) | Watt | 1, 2, 4 |
| LED Life Time | LED_LT | 30,000 | - | - | Hrs | 3 |

Notes) The LED Bar consists of 54 LED packages, 3 strings (parallel) x 18packages (serial) x 1 bar

LED driver design guide

: The design of the LED driver must have specifications for the LED in LCD Assembly.

The performance of the LED in LCM, for example life time or brightness, is extremely influenced by the characteristics of the LED driver.

So all the parameters of an LED driver should be carefully designed and output current should be Constant current control.

Please control feedback current of each string individually to compensate the current variation among the strings of LEDs.

When you design or order the LED driver, please make sure unwanted lighting caused by the mismatch of the LED and the LED driver (no lighting, flicker, etc) never occurs.

When you confirm it, the LCD module should be operated in the same condition as installed in your instrument.

1. The specified values are for a single LED bar.
2. The specified current is defined as the input current for a single LED string with 100% duty cycle.
3. The LED life time is defined as the time when brightness of LED packages become 50% or less than the initial value under the conditions at $T_a = 25 \pm 2^\circ\text{C}$ and LED string current is typical value.
4. The power consumption shown above does not include loss of external driver.
 The typical power consumption is calculated as $P_{\text{Bar}} = V_s(\text{Typ.}) \times I_s(\text{Typ.}) \times \text{No. of strings}$.
 The maximum power consumption is calculated as $P_{\text{Bar}} = V_s(\text{Max.}) \times I_s(\text{Typ.}) \times \text{No. of strings}$.
5. LED operating conditions are must not exceed Max. ratings.

Product Specification
3-2. Interface Connections
Table 3. MODULE CONNECTOR(CN1) PIN CONFIGURATION

| Pin | Symbol | Description | Notes |
|-----|---------|---|--|
| 1 | VIN | Power Supply +10.0V | <p>[Connector] GT05Q-30S-H10-MN, LSMtron, 30pin, 0.5pitch or equivalent</p> <p>[Mating Connector] 20453-030T-01, I-Pex series or equivalent</p> <p>[Connector pin arrangement]</p> |
| 2 | VIN | Power Supply +10.0V | |
| 3 | VIN | Power Supply +10.0V | |
| 4 | VIN | Power Supply +10.0V | |
| 5 | VIN | Power Supply +10.0V | |
| 6 | NC | No Connection | |
| 7 | GND | Ground | |
| 8 | NC | Reserved for LCD manufacture's use | |
| 9 | NC | Reserved for LCD manufacture's use | |
| 10 | GND | Ground | |
| 11 | HPD | Hot Plug Detect Signal | |
| 12 | GND | Ground | |
| 13 | AUX_CHN | Component Signal for Auxiliary Channel | |
| 14 | AUX_CHP | True Signal for Auxiliary Channel | |
| 15 | GND | Ground | |
| 16 | Lane0P | True Signal for Main Link 0 | |
| 17 | Lane0N | Component Signal for Main Link 0 | |
| 18 | GND | Ground | |
| 19 | Lane1P | True Signal for Main Link 1 | |
| 20 | Lane1N | Component Signal for Main Link 1 | |
| 21 | GND | Ground | |
| 22 | Lane2P | True Signal for Main Link 2 | |
| 23 | Lane2N | Component Signal for Main Link 2 | |
| 24 | GND | Ground | |
| 25 | Lane3P | True Signal for Main Link 3 | |
| 26 | Lane3N | Component Signal for Main Link 3 | |
| 27 | GND | Ground | |
| 28 | BIST | L(GND): Black, H(3.3V): Rotational Pattern | |
| 29 | NC | No Connection | |
| 30 | GND | Ground | |

Product Specification

3-2-2. BACKLIGHT CONNECTOR PIN CONFIGURATION(CN2)

- Connector : SM06B-SHJH (HF) (Manufactured by JST) or Yeonho
- Mating Connector : SHJP-06V-S(HF) or SHJP-06V-A-K(HF) or Equivalent

Table 4. LED CONNECTOR PIN CONFIGURATION

| Pin | Symbol | Description |
|-----|--------|---------------------------|
| 1 | FB1 | Channel1 Current Feedback |
| 2 | NC | No Connection |
| 3 | VLED | LED Power Supply |
| 4 | VLED | LED Power Supply |
| 5 | FB2 | Channel2 Current Feedback |
| 6 | FB3 | Channel3 Current Feedback |

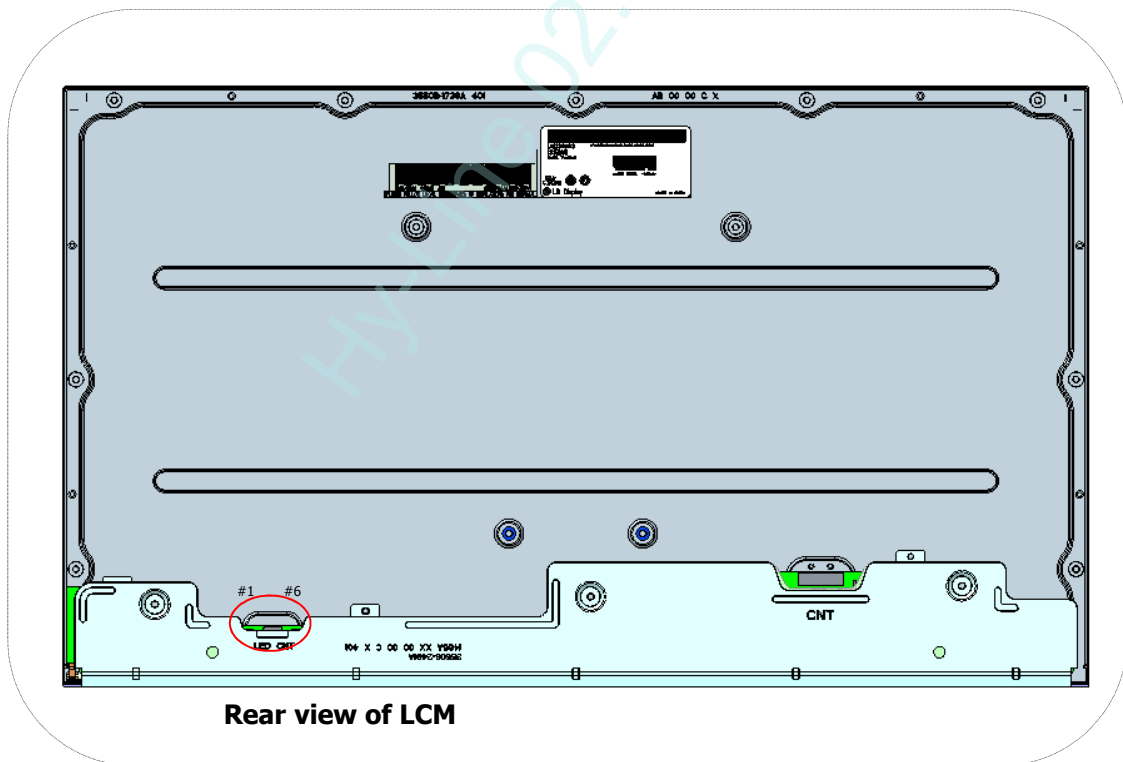

[Figure 4] Backlight connector view

Product Specification

3-3. eDP Signal Specifications

3-3-1. eDP Main Link Signal

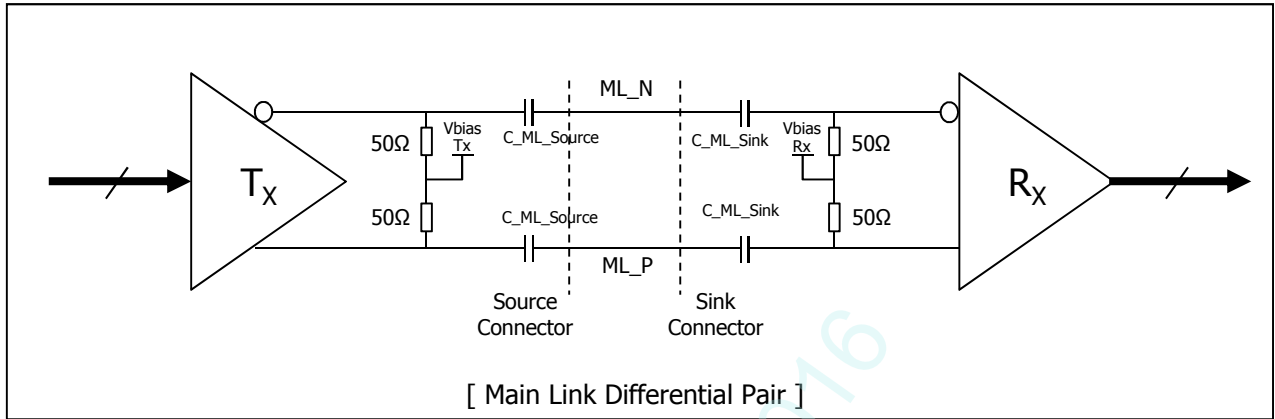

| Parameter | Symbol | Min | Typ | Max | Unit | Notes |
|--|---------------------------|------|-----|---------------|------|-------------|
| Unit Interval for high bit rate (5.4Gbps / lane) | UI_HBR2 | - | 185 | - | ps | |
| Link Clock Down Spreading | Amplitude | 0 | - | 0.5 | % | |
| | Frequency | 30 | | 33 | kHz | |
| Differential peak-to-peak voltage at Sink side connector | $V_{RX-DIFFP-P}$ | - | - | 1.38 | V | Note 6,7) |
| EYE width at Sink side connector | $T_{RX-EYE-CONN}$ | 0.38 | - | - | UI | Note 6,7) |
| Lane-to-Lane skew | $L_{RX-SKEW-INTER_PAIR}$ | - | - | 4UI+ 500ps | | |
| Lane intra-pair skew | $L_{RX-SKEW-INTRA_PAIR}$ | - | - | 50 | ps | |
| AC Coupling Capacitor | $C_{SOURCE-ML}$ | 75 | | 200 | nF | Source side |

Note)

1. Termination resistor is typically integrated into the transmitter and receiver implementations.
2. In cabled embedded system, it is recommended the system designer ensure that EYE width and voltage are met at the sink side connector pins.
3. Mismatched common mode voltage will occur abnormal display.
4. All eDP electrical spec is measured at sink connector side.
5. eDP cable Impedance recommend 100ohm ± 5%.

Product Specification

Note6) Definition of Differential Voltage

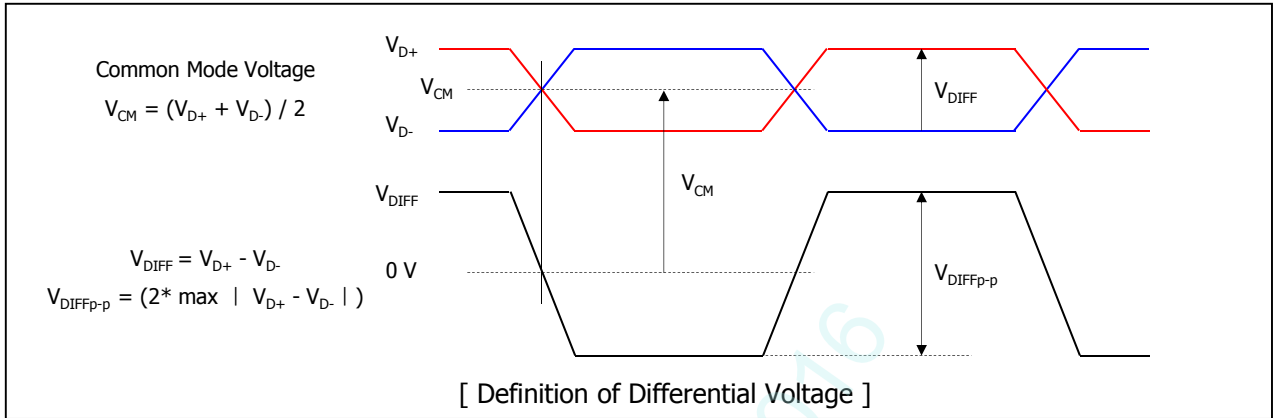

Note7) Main Link EYE Diagram

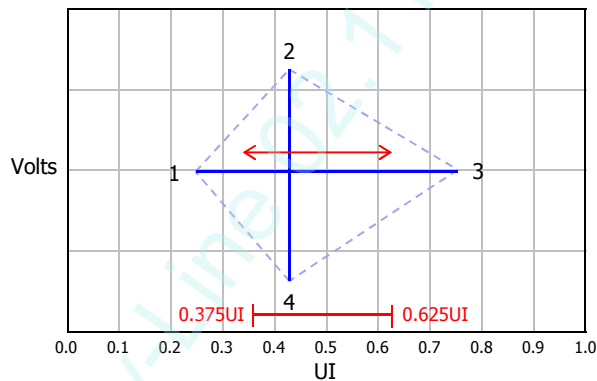

| Point | High Bit Rate 2 @ TP3 EQ | |
|-------|--|------------|
| | Time(UI) | Voltage(V) |
| 1 | Any UI location (x) where the eye width is open from x to x+0.38UI | 0.000 |
| 2 | Any passing UI location between 0.375UI-0.625UI | 0.045 |
| 3 | Point 1 + 0.38UI | 0.000 |
| 4 | Same as Point 2 | -0.045 |

[EYE Mask Vertices at embedded DP Sink Connector Pins]

Product Specification

3-3-2. eDP AUX Channel Signal

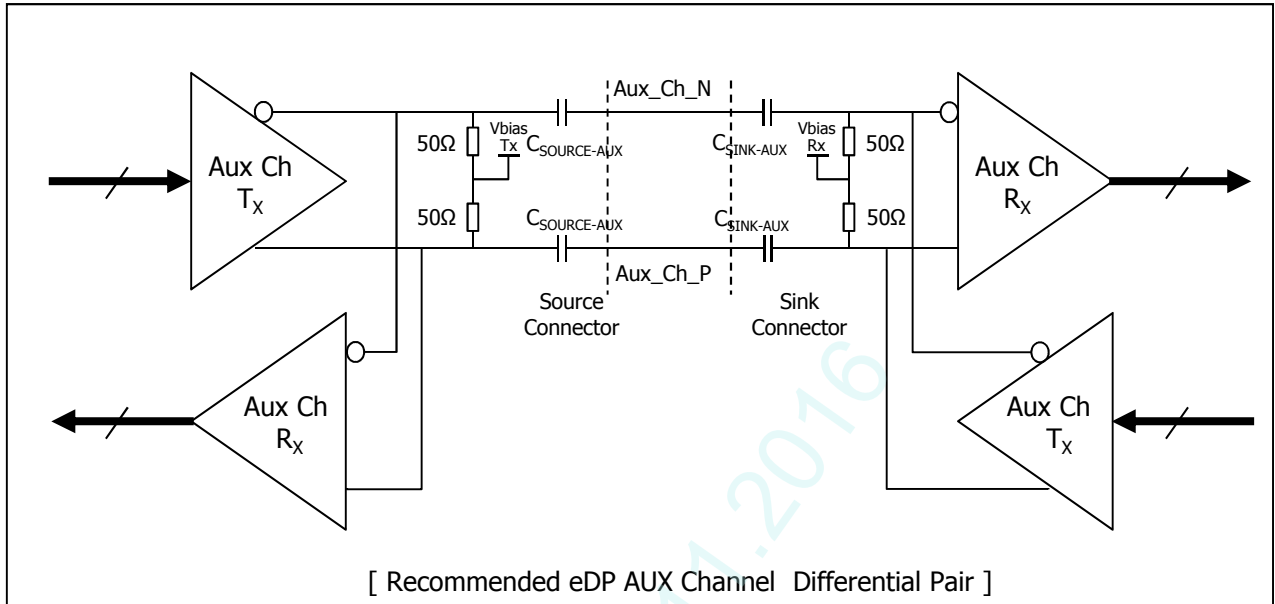

| Parameter | Symbol | Min | Typ | Max | Unit | Notes |
|--|-------------------|------|------|------|------|---------------|
| AUX Unit Interval | UI | 0.4 | - | 0.6 | us | |
| AUX Jitter at Tx IC Package Pins | T_{jitter} | - | - | 0.04 | UI | Equal to 24ns |
| AUX Jitter at Rx IC Package Pins | | - | - | 0.05 | UI | Equal to 30ns |
| AUX Peak-to-peak voltage at Connector Pins of Receiving | $V_{AUX-DIFFp-p}$ | 0.32 | - | 1.36 | V | |
| AUX Peak-to-peak voltage at Connector Pins of Transmitting | | 0.39 | - | 1.38 | V | |
| AUX EYE width at Connector Pins of Tx and Rx | | 0.98 | - | - | UI | |
| AUX DC common mode voltage | V_{AUX-CM_Rx} | - | 0 | 2.0 | V | |
| | V_{AUX-CM_Tx} | - | 0.15 | 2.0 | V | |
| AUX AC Coupling Capacitor | $C_{SOURCE-AUX}$ | 75 | | 200 | nF | Source side |

Note)

1. Termination resistor is typically integrated into the transmitter and receiver implementations.
2. $V_{AUX-DIFFp-p} = 2 * | V_{AUXP} - V_{AUXN} |$
3. Termination resistor should be $\pm 50\Omega$ at source side to AUX level.
4. At sink side AUX cap. are for protection ESD/EOS damage.
5. Mismatched common mode voltage will occur abnormal display.

Product Specification

3-3-3. eDP HPD Signal

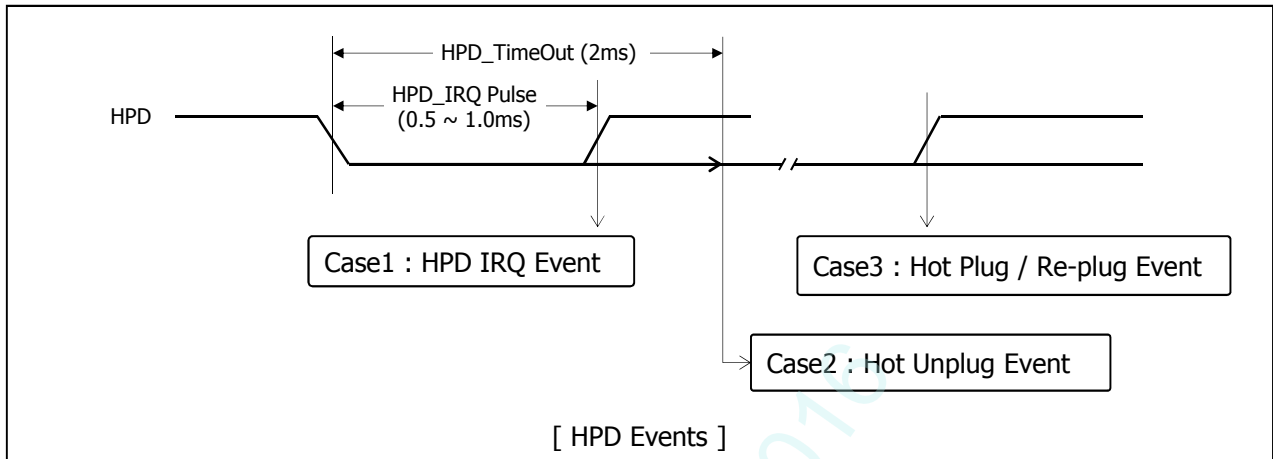

| Parameter | Symbol | Min | Typ | Max | Unit | Notes |
|--------------------------------|---------|------|-----|-----|------|-----------------------|
| HPD Voltage | HPD | 2.25 | - | 3.6 | V | Sink side Driving |
| Hot Plug Detection Threshold | | 2.0 | - | - | V | Source side Detecting |
| Hot Unplug Detection Threshold | | - | - | 0.8 | V | |
| HPD_IRQ Pulse Width | HPD_IRQ | 0.5 | - | 1.0 | ms | |
| HPD_TimeOut | | 2.0 | - | - | ms | HPD Unplug Event |

Note)

1. HPD IRQ : Sink device wants to notify the Source device that Sink's status has changed so it toggles HPD line, forcing the Source device to read its Link / Sink Receiver DPCD field via the AUX-CH
2. HPD Unplug : The Sink device is no longer attached to the Source device and the Source device may then disable its Main Link as a power saving mode
3. Plug / Re-plug : The Sink device is now attached to the Source device, forcing the Source device to read its Receiver capabilities and Link / Sink status Receiver DPCD fields via the AUX-CH

Product Specification
3-4. Signal Timing Specifications

All of the interface signal timing should be satisfied with the following specifications for it's proper operation.

Table 5. TIMING TABLE

| ITEM | | SYMBOL | Min | Typ | Max | Unit | Note |
|-------------|------------------------|--------|--------|--------|--------|------|-----------------|
| DCLK | Period | tCLK | 1.82 | 1.875 | 1.93 | ns | |
| | Frequency | fCLK | 518.25 | 533.25 | 548.25 | MHz | - |
| Hsync | Period | tHP | 3968 | 4000 | 4040 | tCLK | |
| | Width-Active | tWH | 28 | 32 | 36 | | |
| Vsync | Period | tVP | 2220 | 2222 | 2268 | tHP | |
| | Frequency | fV | 58.2 | 59.997 | 61.68 | Hz | |
| | Width-Active | tWV | 5 | 5 | 5 | tHP | |
| Data Enable | Horizontal Valid | tHV | 3840 | 3840 | 3840 | tCLK | |
| | Horizontal Back Porch | tHBP | 52 | 80 | 116 | | |
| | Horizontal Front Porch | tHFP | 48 | 48 | 48 | | |
| | Horizontal Blank | - | 128 | 160 | 200 | | tWH+ tHBP+ tHFP |
| | Vertical Valid | tVV | 2160 | 2160 | 2160 | tHP | |
| | Vertical Back Porch | tVBP | 52 | 54 | 100 | | |
| | Vertical Front Porch | tVFP | 3 | 3 | 3 | | |
| | Vertical Blank | - | 60 | 62 | 108 | | tWV+ tVBP+ tVFP |

Note:

1. DE Only mode operation. The input of Hsync & Vsync signal does not have an effect on LCD normal operation.
2. The performance of the electro-optical characteristics may be influenced by variance of the vertical refresh rates.
3. Horizontal period should be even.

Product Specification

3-5. Signal Timing Waveforms

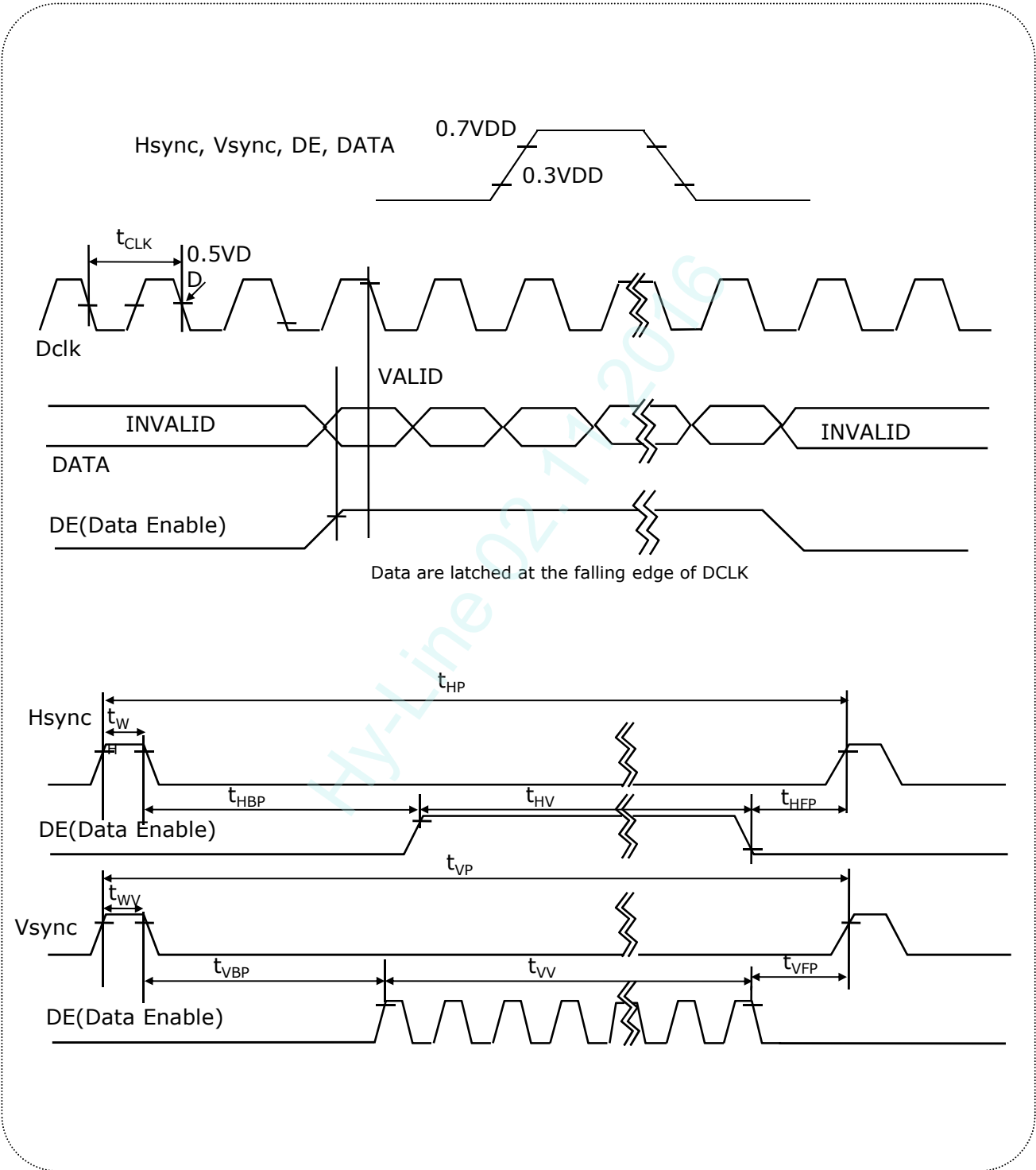

Product Specification
3-6. Color Input Data Reference

The Brightness of each primary color(red,green,blue) is based on the 10-bit gray scale data input for the color; the higher the binary input, the brighter the color. The table below provides a reference for color versus data input.

Table 6. COLOR DATA REFERENCE

| Color | | Input Color Data | | | | | | | | | | | | | | | | | | | | | | | | | | | | | |
|-------------|--------------|------------------|-----|----|----|----|----|----|----|----|-----|-------|----|----|----|----|----|----|----|-----|-----|------|----|----|----|----|----|----|----|----|----|
| | | RED | | | | | | | | | | GREEN | | | | | | | | | | BLUE | | | | | | | | | |
| | | MSB | LSB | | | | | | | | MSB | LSB | | | | | | | | MSB | LSB | | | | | | | | | | |
| | | R9 | R8 | R7 | R6 | R5 | R4 | R3 | R2 | R1 | R0 | G9 | G8 | G7 | G6 | G5 | G4 | G3 | G2 | G1 | G0 | B9 | B8 | B7 | B6 | B5 | B4 | B3 | B2 | B1 | B0 |
| Basic Color | Black | 0 | 0 | 0 | 0 | 0 | 0 | 0 | 0 | 0 | 0 | 0 | 0 | 0 | 0 | 0 | 0 | 0 | 0 | 0 | 0 | 0 | 0 | 0 | 0 | 0 | 0 | 0 | 0 | 0 | 0 |
| | Red (1023) | 1 | 1 | 1 | 1 | 1 | 1 | 1 | 1 | 1 | 1 | 0 | 0 | 0 | 0 | 0 | 0 | 0 | 0 | 0 | 0 | 0 | 0 | 0 | 0 | 0 | 0 | 0 | 0 | 0 | 0 |
| | Green (1023) | 0 | 0 | 0 | 0 | 0 | 0 | 0 | 0 | 0 | 0 | 1 | 1 | 1 | 1 | 1 | 1 | 1 | 1 | 1 | 1 | 0 | 0 | 0 | 0 | 0 | 0 | 0 | 0 | 0 | 0 |
| | Blue (1023) | 0 | 0 | 0 | 0 | 0 | 0 | 0 | 0 | 0 | 0 | 0 | 0 | 0 | 0 | 0 | 0 | 0 | 0 | 0 | 0 | 1 | 1 | 1 | 1 | 1 | 1 | 1 | 1 | 1 | 1 |
| | Cyan | 0 | 0 | 0 | 0 | 0 | 0 | 0 | 0 | 0 | 0 | 1 | 1 | 1 | 1 | 1 | 1 | 1 | 1 | 1 | 1 | 1 | 1 | 1 | 1 | 1 | 1 | 1 | 1 | 1 | 1 |
| | Magenta | 1 | 1 | 1 | 1 | 1 | 1 | 1 | 1 | 1 | 1 | 0 | 0 | 0 | 0 | 0 | 0 | 0 | 0 | 0 | 0 | 1 | 1 | 1 | 1 | 1 | 1 | 1 | 1 | 1 | 1 |
| | Yellow | 1 | 1 | 1 | 1 | 1 | 1 | 1 | 1 | 1 | 1 | 1 | 1 | 1 | 1 | 1 | 1 | 1 | 1 | 1 | 1 | 0 | 0 | 0 | 0 | 0 | 0 | 0 | 0 | 0 | 0 |
| | White | 1 | 1 | 1 | 1 | 1 | 1 | 1 | 1 | 1 | 1 | 1 | 1 | 1 | 1 | 1 | 1 | 1 | 1 | 1 | 1 | 1 | 1 | 1 | 1 | 1 | 1 | 1 | 1 | 1 | 1 |
| RED | RED (000) | 0 | 0 | 0 | 0 | 0 | 0 | 0 | 0 | 0 | 0 | 0 | 0 | 0 | 0 | 0 | 0 | 0 | 0 | 0 | 0 | 0 | 0 | 0 | 0 | 0 | 0 | 0 | 0 | 0 | |
| | RED (001) | 0 | 0 | 0 | 0 | 0 | 0 | 0 | 0 | 0 | 0 | 0 | 0 | 0 | 0 | 0 | 0 | 0 | 0 | 0 | 0 | 0 | 0 | 0 | 0 | 0 | 0 | 0 | 0 | 0 | |
| | ... | ... | | | | | | | | | | ... | | | | | | | | | | ... | | | | | | | | | |
| | RED (1022) | 1 | 1 | 1 | 1 | 1 | 1 | 1 | 1 | 1 | 0 | 0 | 0 | 0 | 0 | 0 | 0 | 0 | 0 | 0 | 0 | 0 | 0 | 0 | 0 | 0 | 0 | 0 | 0 | 0 | 0 |
| | RED (1023) | 1 | 1 | 1 | 1 | 1 | 1 | 1 | 1 | 1 | 1 | 0 | 0 | 0 | 0 | 0 | 0 | 0 | 0 | 0 | 0 | 0 | 0 | 0 | 0 | 0 | 0 | 0 | 0 | 0 | 0 |
| GREEN | GREEN (000) | 0 | 0 | 0 | 0 | 0 | 0 | 0 | 0 | 0 | 0 | 0 | 0 | 0 | 0 | 0 | 0 | 0 | 0 | 0 | 0 | 0 | 0 | 0 | 0 | 0 | 0 | 0 | 0 | 0 | |
| | GREEN (001) | 0 | 0 | 0 | 0 | 0 | 0 | 0 | 0 | 0 | 0 | 0 | 0 | 0 | 0 | 0 | 0 | 0 | 0 | 0 | 0 | 0 | 0 | 0 | 0 | 0 | 0 | 0 | 0 | 0 | |
| | ... | ... | | | | | | | | | | ... | | | | | | | | | | ... | | | | | | | | | |
| | GREEN (1022) | 0 | 0 | 0 | 0 | 0 | 0 | 0 | 0 | 0 | 1 | 1 | 1 | 1 | 1 | 1 | 1 | 1 | 1 | 0 | 0 | 0 | 0 | 0 | 0 | 0 | 0 | 0 | 0 | 0 | |
| | GREEN (1023) | 0 | 0 | 0 | 0 | 0 | 0 | 0 | 0 | 0 | 1 | 1 | 1 | 1 | 1 | 1 | 1 | 1 | 1 | 1 | 0 | 0 | 0 | 0 | 0 | 0 | 0 | 0 | 0 | 0 | |
| BLUE | BLUE (000) | 0 | 0 | 0 | 0 | 0 | 0 | 0 | 0 | 0 | 0 | 0 | 0 | 0 | 0 | 0 | 0 | 0 | 0 | 0 | 0 | 0 | 0 | 0 | 0 | 0 | 0 | 0 | 0 | 0 | |
| | BLUE (001) | 0 | 0 | 0 | 0 | 0 | 0 | 0 | 0 | 0 | 0 | 0 | 0 | 0 | 0 | 0 | 0 | 0 | 0 | 0 | 0 | 0 | 0 | 0 | 0 | 0 | 0 | 0 | 0 | 1 | |
| | ... | ... | | | | | | | | | | ... | | | | | | | | | | ... | | | | | | | | | |
| | BLUE (1022) | 0 | 0 | 0 | 0 | 0 | 0 | 0 | 0 | 0 | 0 | 0 | 0 | 0 | 0 | 0 | 0 | 0 | 0 | 0 | 1 | 1 | 1 | 1 | 1 | 1 | 1 | 1 | 0 | 0 | |
| | BLUE (1023) | 0 | 0 | 0 | 0 | 0 | 0 | 0 | 0 | 0 | 0 | 0 | 0 | 0 | 0 | 0 | 0 | 0 | 0 | 0 | 1 | 1 | 1 | 1 | 1 | 1 | 1 | 1 | 1 | 1 | |

Product Specification

3-7. Power Sequence

3-7-1. Power Sequence

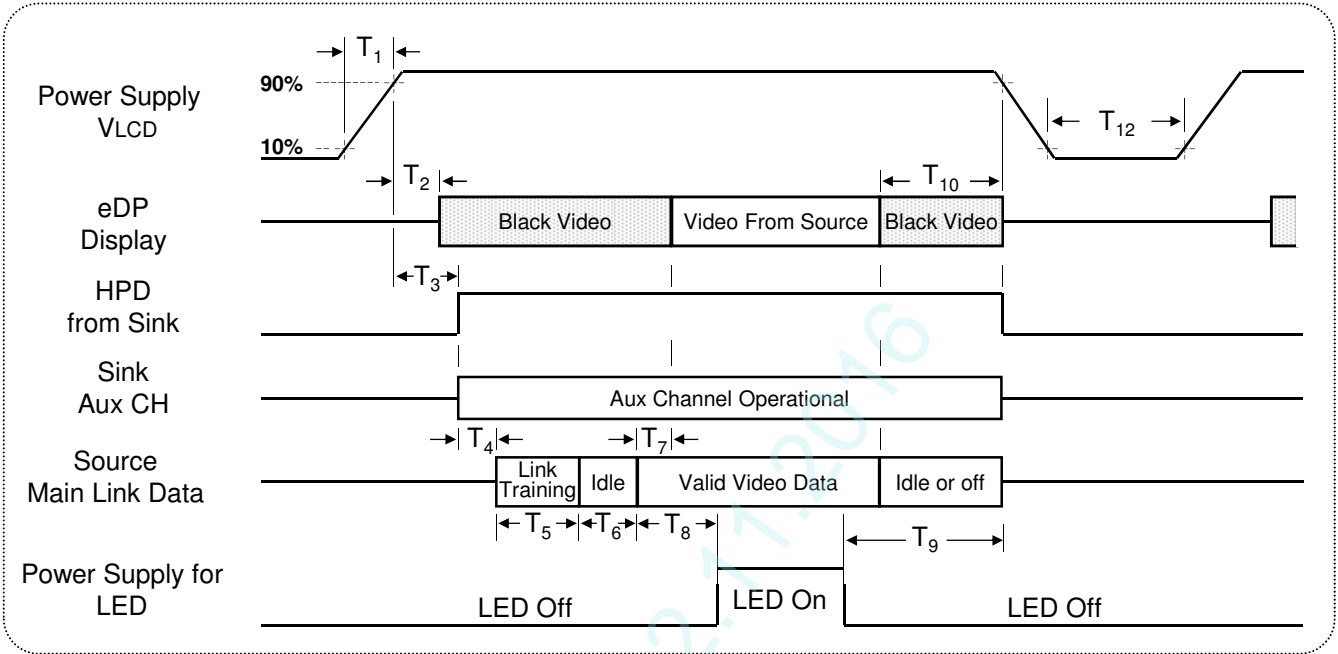

Table 7. POWER SEQUENCE TABLE

| Timing | Required By | Limits | | Units | Notes |
|----------------|-------------|--------|-----|-------|-------|
| | | Min | Max | | |
| T ₁ | Source | 0.5 | 10 | ms | - |
| T ₂ | Sink | 10 | 200 | ms | - |
| T ₃ | Sink | 15 | 200 | ms | - |
| T ₄ | Source | - | - | ms | 6 |
| T ₅ | Source | - | - | ms | 6 |
| T ₆ | Source | - | 100 | ms | - |
| T ₇ | Sink | 0 | 50 | ms | - |
| T ₈ | Source | 200 | - | ms | |
| T ₉ | Source | 200 | - | ms | 7 |

| Timing | Required By | Limits | | Units | Notes |
|-----------------|-------------|--------|-----|-------|-------|
| | | Min | Max | | |
| T ₁₀ | Source | 0 | 500 | ms | - |
| T ₁₂ | Source | 1000 | - | ms | |

- Note) 1. Do not insert the mating cable when system turn on.
 2. Valid Data have to meet "3-3. Signal Timing Specifications"
 3. When the Video signal is invalid, be sure to pull down the power supply for LCD VLCD to 0V.
 4. The above power sequence should be satisfied the basic power on/off and resolution, timing transition.
 5. LED power must be turn on after power supply for LCD and valid status of Video Signal.
 6. Link training duration is dependent on the customer's system.
 7. LED power must be turned off while Video data signal is valid

Product Specification

3-7-2. V_{LCD} Power Dip Condition

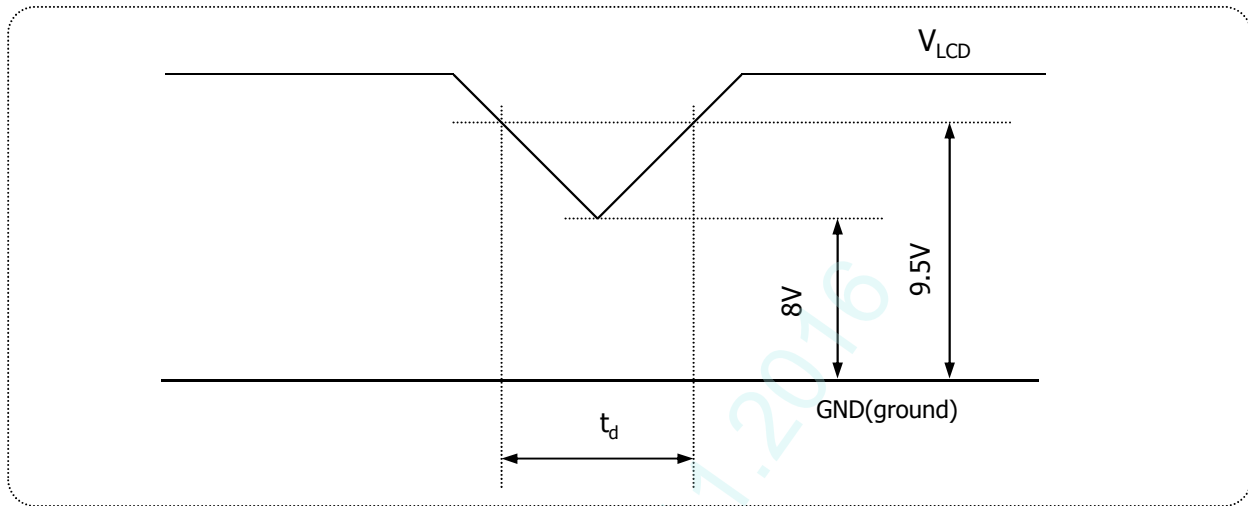

FIG.5 Power dip condition

1) Dip condition

$$8V \leq V_{LCD} < 9.5V, t_d \leq 20ms$$

2) $V_{LCD} < 8V$

V_{LCD} -dip conditions should also follow the Power On/Off conditions for supply voltage.

Product Specification
4. Optical Specifications

Optical characteristics are determined after the unit has been 'ON' for approximately 30 minutes in a dark environment at $25 \pm 2^\circ\text{C}$. The values specified are at an approximate distance 50cm from the LCD surface at a viewing angle of Φ and θ equal to 0° and aperture 1 degree.

FIG. 6 presents additional information concerning the measurement equipment and method.

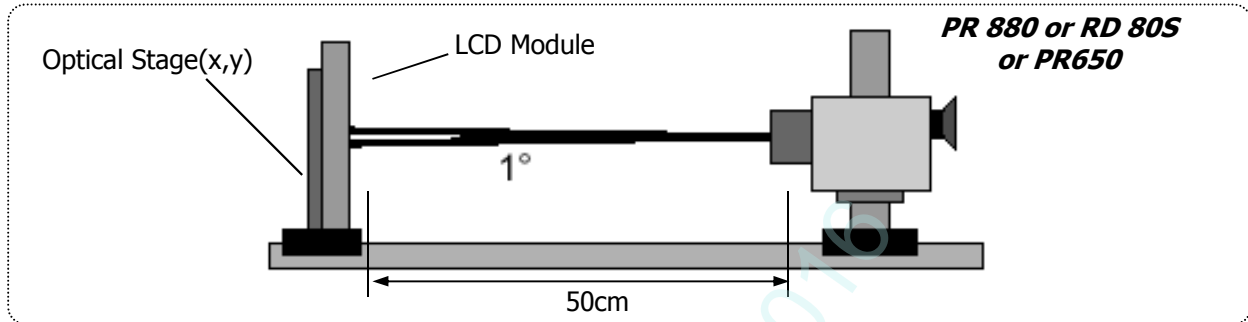

FIG.6 Optical Characteristic Measurement Equipment and Method

Table 8. OPTICAL CHARACTERISTICS

($T_a=25^\circ\text{C}$, $V_{LCD}=10\text{V}$, $f_v=60\text{Hz}$ Dclk=533.25MHz) $I_s=120\text{mA}$

| Parameter | Symbol | Values | | | Units | Notes | |
|--|------------------|-------------------|--------|-------|-------------------|--------|---|
| | | Min | Typ | Max | | | |
| Contrast Ratio | CR | (910) | (1300) | - | | 1 | |
| Surface Luminance, white | L_{WH} | 280 | 350 | - | cd/m ² | 2 | |
| Luminance Variation | δ_{WHITE} | 75 | - | - | % | 3 | |
| Response Time | Gray To Gray | T_{GTG_AVR} | - | 14 | 25 | ms | 4 |
| Color Coordinates [CIE1931] (By PR650) | RED | R_x | | TBD | | | |
| | | R_y | | TBD | | | |
| | GREEN | G_x | | TBD | | | |
| | | G_y | Typ | TBD | Typ | | |
| | BLUE | B_x | -0.03 | TBD | +0.03 | | |
| | | B_y | | TBD | | | |
| | WHITE | W_x | | 0.313 | | | |
| | W_y | | 0.329 | | | | |
| Color Shift | Horizontal | θ_{CST_H} | - | 178 | - | Degree | 5 |
| | Vertical | θ_{CST_V} | - | 178 | - | | |
| Viewing Angle (CR>10) | | | | | | | |
| General | Horizontal | θ_H | 170 | 178 | - | Degree | 6 |
| | Vertical | θ_V | 170 | 178 | - | | |
| Gray Scale | | - | | 2.2 | | 7 | |

Product Specification

Notes

1. Contrast Ratio(CR) is defined mathematically as : **(By PR880)**

$$\text{Contrast Ratio} = \frac{\text{Surface Luminance with all white pixels}}{\text{Surface Luminance with all black pixels}}$$

It is measured at center point(Location P1)

2. Surface luminance(L_{WH}) is luminance value at Center 1 point(P1) across the LCD surface 50cm from the surface with all pixels displaying white. For more information see FIG.7 (By PR880)

3. The variation in surface luminance , δ WHITE is defined as : **(By PR880)**

$$\delta_{\text{WHITE}} = \frac{\text{Minimum}(L_{P1}, L_{P2}, \dots, L_{P9})}{\text{Maximum}(L_{P1}, L_{P2}, \dots, L_{P9})} \times 100$$

Where L1 to L9 are the luminance with all pixels displaying white at 9 locations.
For more information see FIG.7

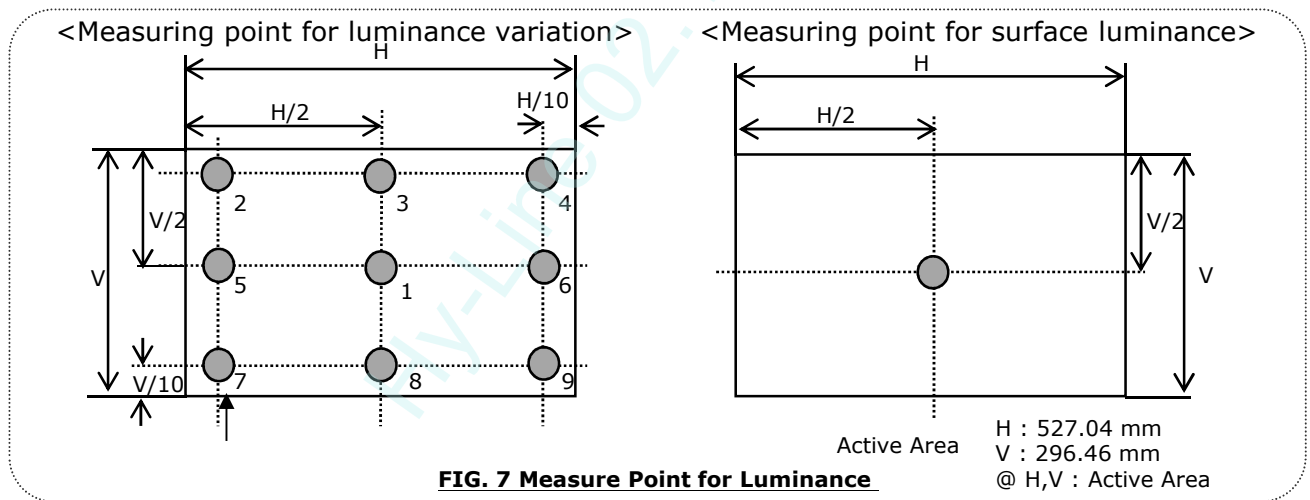

Product Specification

4. Gray to gray response time is the time required for the display to transition from gray to gray. For additional information see Table 9. **(By PR880)**

Table 9. Gray to gray response time table

| Gray to Gray | | Rising Time | | | | |
|--------------|-------|-------------|------|------|------|----|
| | | G1023 | G767 | G511 | G255 | G0 |
| Falling Time | G1023 | | | | | |
| | G767 | | | | | |
| | G511 | | | | | |
| | G255 | | | | | |
| | G0 | | | | | |

The response time is defined as the following figure and shall be measured by switching the input signal for "black" and "white".

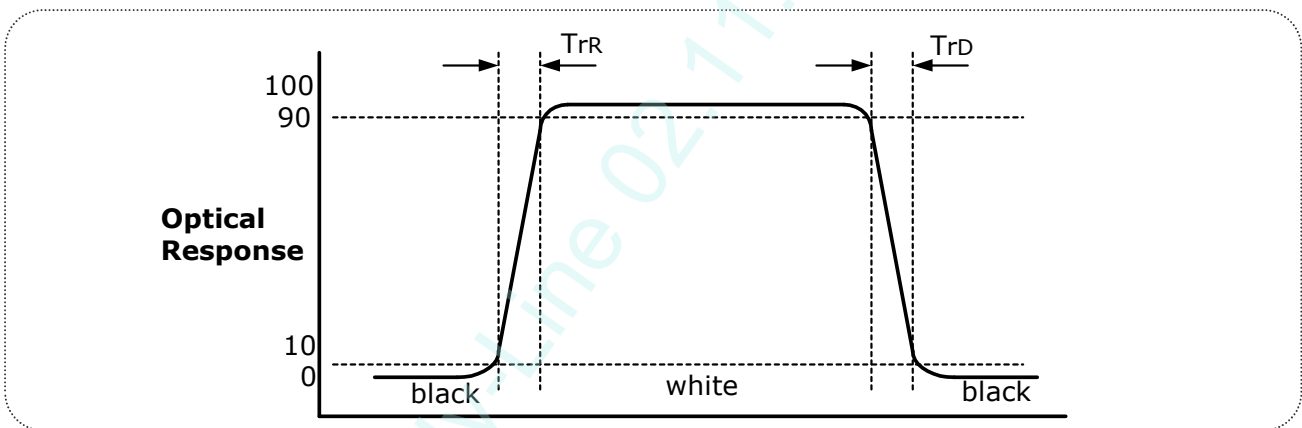

FIG.8 Response time

Product Specification

5. Color shift is the angle at which the average color difference for all Macbeth is lower than 0.02.

For more information see FIG.9 **(By EZ Contrast)**

- Color difference ($\Delta u'v'$)

$$u' = \frac{4x}{-2x+12y+3} \quad v' = \frac{9y}{-2x+12y+3} \quad \Delta u'v' = \sqrt{(u'_1 - u'_2)^2 + (v'_1 - v'_2)^2}$$

$$Avg (\Delta u'v') = \frac{\sum_{i=1}^{24} (\Delta u'v')_i}{24}$$

u'_1, v'_1 : $u'v'$ value at viewing angle direction
 u'_2, v'_2 : $u'v'$ value at front ($\theta=0$)
 i : Macbeth chart number (Define 23 page)

- Pattern size : 25% Box size
- Viewing angle direction of color shift : Horizontal, Vertical

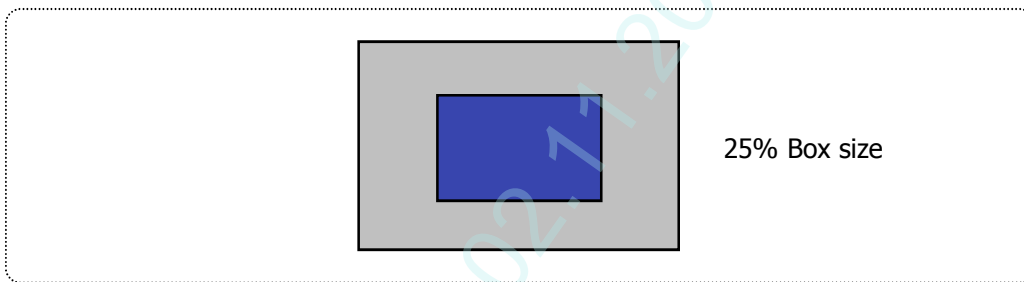

FIG.9 Color Shift Test Pattern

Average RGB values in Bruce RGB for Macbeth Chart

| | | | | | | |
|---|-----------|---------------|--------------|-----------|--------------|---------------|
| | Dark skin | Light skin | Blue sky | Foliage | Blue flower | Bluish green |
| R | 395 | 827 | 343 | 311 | 519 | 459 |
| G | 227 | 571 | 451 | 411 | 475 | 799 |
| B | 183 | 495 | 647 | 187 | 743 | 715 |
| | Orange | Purplish blue | Moderate red | Purple | Yellow green | Orange yellow |
| R | 879 | 227 | 847 | 307 | 643 | 923 |
| G | 419 | 279 | 271 | 159 | 775 | 651 |
| B | 99 | 699 | 351 | 347 | 235 | 119 |
| | Blue | Green | Red | Yellow | Magenta | cyan |
| R | 107 | 291 | 791 | 967 | 831 | 143 |
| G | 131 | 595 | 111 | 851 | 251 | 507 |
| B | 583 | 263 | 151 | 147 | 607 | 691 |
| | White | Neutral 8 | Neutral 6.5 | Neutral 5 | Neutral 3.5 | black |
| R | 963 | 827 | 623 | 443 | 255 | 91 |
| G | 963 | 827 | 623 | 443 | 255 | 91 |
| B | 963 | 827 | 623 | 443 | 255 | 91 |

Product Specification

6. Viewing angle is the angle at which the contrast ratio is greater than 10. The angles are determined for the horizontal or x axis and the vertical or y axis with respect to the z axis which is normal to the LCD surface. For more information see FIG.10 **(By PR880)**

Dimension of viewing angle range.

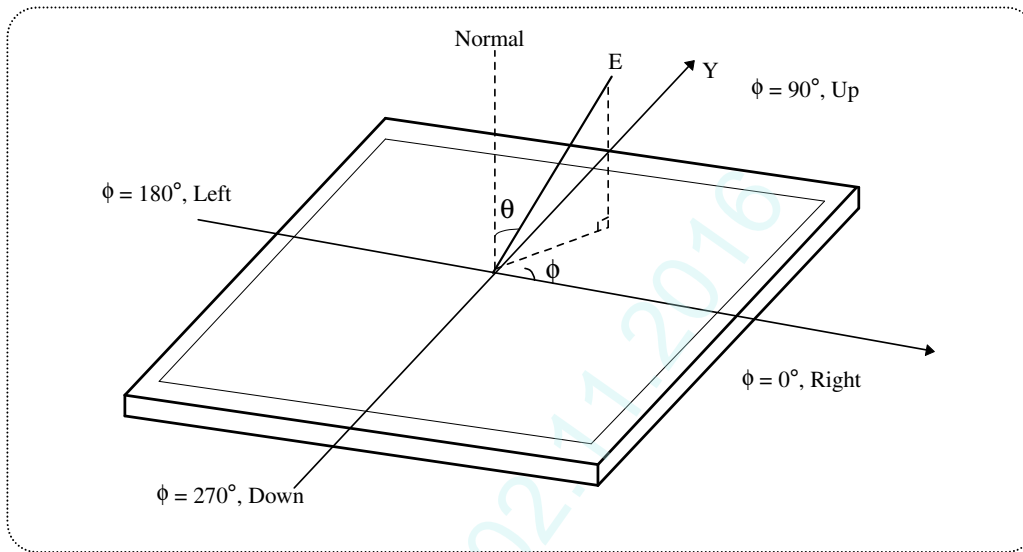

FIG.10 Viewing angle

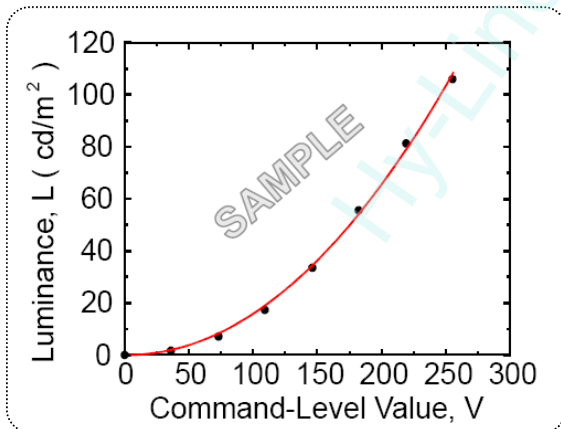

FIG.11 Sample Luminance vs. gray scale (using a 256 bit gray scale)

$$L = aV^{\gamma} + L_b$$

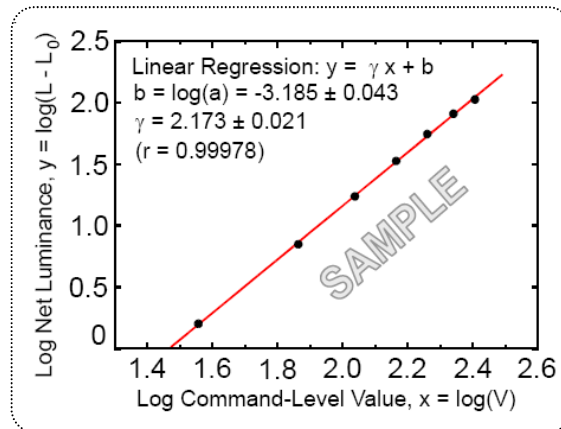

FIG.12 Sample Log-log plot of luminance vs. gray scale

$$\log(L - L_b) = r \log(V) + \log(a)$$

Here the Parameter a and γ relate the signal level V to the luminance L.
The GAMMA we calculate from the log-log representation (FIG.10)

Product Specification

7. Gamma Value is approximately 2.2. For more information see Table 10.

Table 10. Gray Scale Specification

| Gray Level | Relative Luminance [%] (Typ.) |
|------------|-------------------------------|
| 0 | 0.10 |
| 63 | 0.30 |
| 127 | 1.08 |
| 191 | 2.50 |
| 255 | 4.71 |
| 319 | 7.70 |
| 383 | 11.52 |
| 447 | 16.18 |
| 511 | 21.72 |
| 575 | 28.15 |
| 639 | 35.51 |
| 703 | 43.81 |
| 767 | 53.07 |
| 831 | 63.30 |
| 895 | 74.52 |
| 959 | 86.75 |
| 1023 | 100 |

Product Specification

5. Mechanical Characteristics

The contents provide general mechanical characteristics. In addition the figures in the next page are detailed mechanical drawing of the LCD.

| | | |
|---------------------|---|-----------------|
| Outline Dimension | Horizontal | 536.3mm |
| | Vertical | 313.9mm |
| | Depth | 12.9 mm |
| Bezel Area | Horizontal | - |
| | Vertical | - |
| Active Display Area | Horizontal | 525.66mm |
| | Vertical | 295.70mm |
| Weight | 1610g (Typ.) 1690g (Max.) | |
| Surface Treatment | Advanced Anti-glare treatment of the front polarizer (3H) | |

Notes : Please refer to a mechanic drawing in terms of tolerance at the next page.

Hy-Line 02-17-2016

Product Specification

<FRONT VIEW>

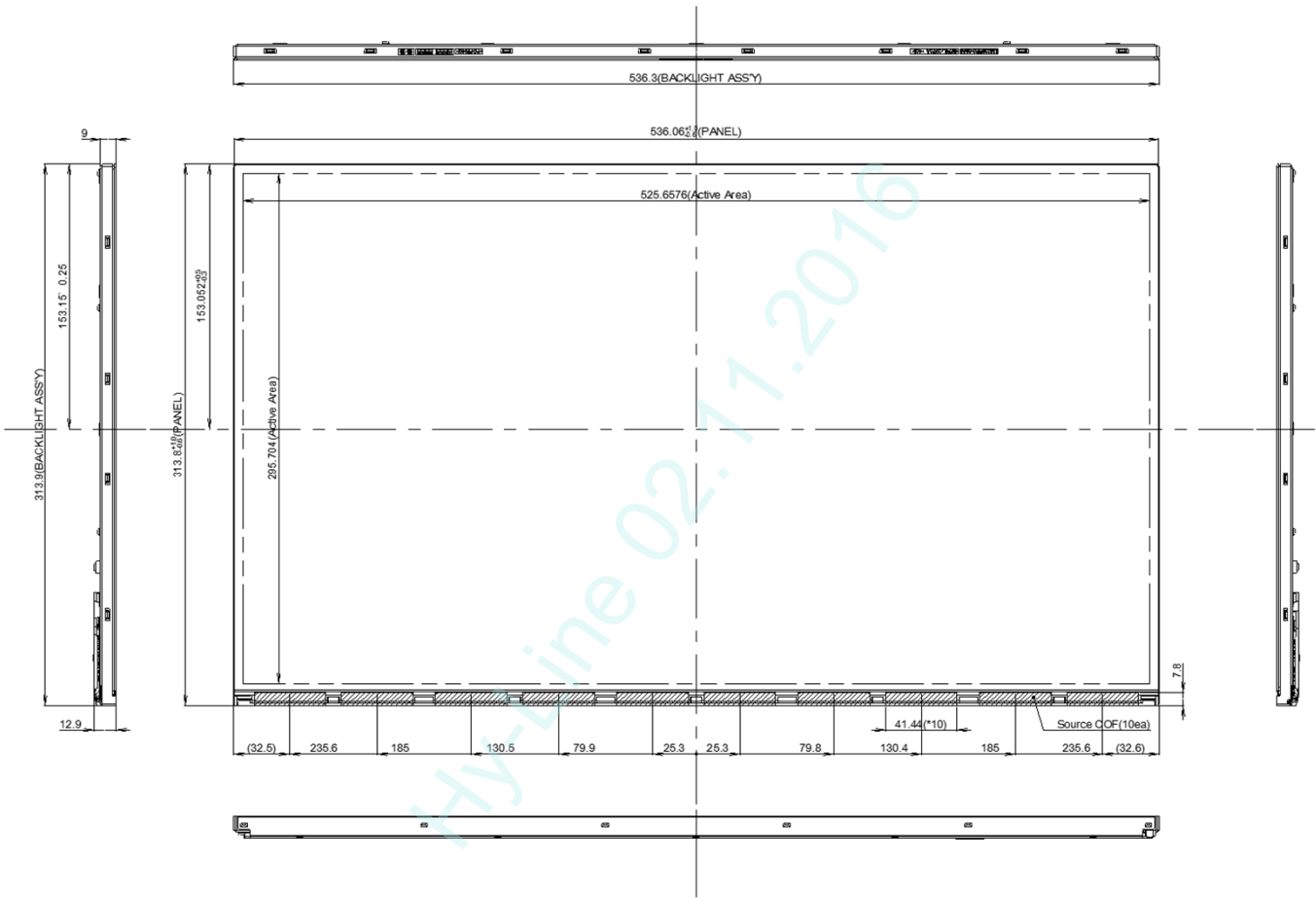

Product Specification

<REAR VIEW>

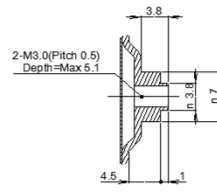
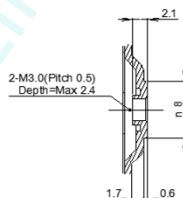
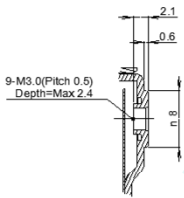
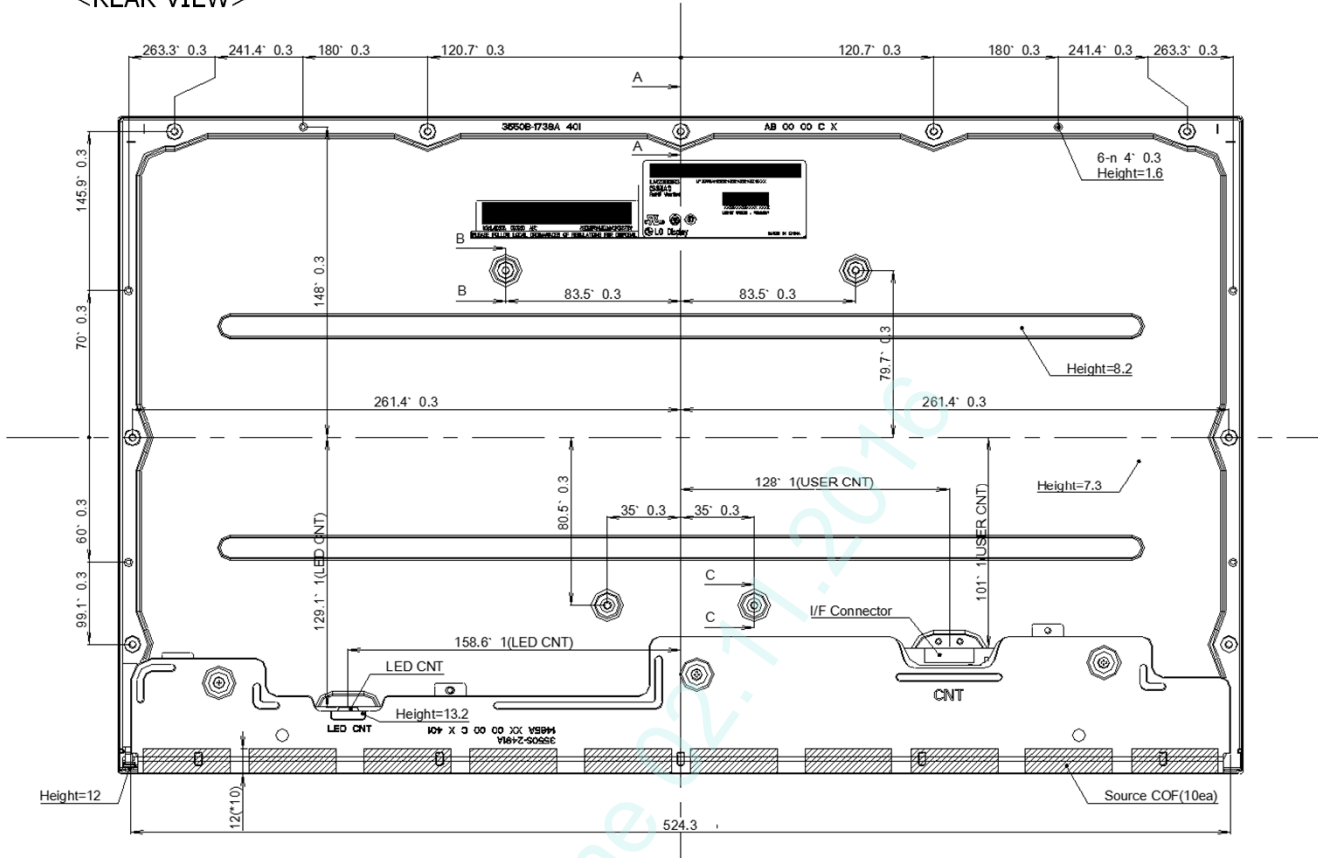

Notes

1. I/F connector specification : GT05Q-30S-H10-MN(LSMtron) or Equivalent.
2. LED connector specification : SMO8B-SHJH(HF)(Manufactured by JST) or Equivalent.
3. Torque of user hole: 3.0~4.0(kgf-cm).
4. Tilt and partial disposition tolerance of display area as following
 - (1) Y-direction : $-0.45 < A < 0.45$, $-0.45 < B < 0.45$
 - (2) X-direction : $-0.45 < C < 0.45$, $-0.45 < D < 0.45$

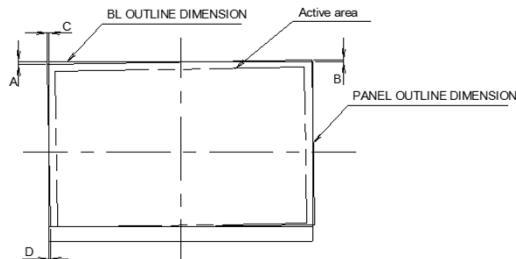

5. Unspecified tolerances to be ± 0.5
6. The LCM warp(warpage) is less than 1.0 on the surface plate
7. The COF area is weak & sensitive, so please don't press the COF area

Product Specification
6. Reliability

Environment test condition

| No | Test Item | Condition | Notes |
|----|--|---|-------|
| 1 | High temperature storage test | Ta= 60°C 240h | 1 |
| 2 | Low temperature storage test | Ta= -20°C 240h | 1 |
| 3 | High temperature operation test | Ta= 50°C 50%RH 240h | 1 |
| 4 | Low temperature operation test | Ta= 0°C 240h | 1 |
| 5 | Humidity condition Operation | Ta= 40 °C ,90%RH | |
| 6 | Altitude operating storage / shipment | 0 – 16,400 feet(5,000m) 0 - 40,000 feet(12,192m) | |
| 7 | Maximum Storage Humidity for 4 corner light leakage Mura. | Max 70%RH , Ta=40°C | |

Note 1. Result Evaluation Criteria:

TFT-LCD panels test should take place after cooling enough at room temperature.

In the standard condition, there should be no particular problems that may affect the display function.

 ※. T_a= Ambient Temperature

7. International Standards

7-1. Safety

- a) UL 60950-1, Underwriters Laboratories Inc.
Information Technology Equipment - Safety - Part 1 : General Requirements.
- b) CAN/CSA-C22.2 No. 60950-1-07, Canadian Standards Association.
Information Technology Equipment - Safety - Part 1 : General Requirements.
- c) EN 60950-1, European Committee for Electrotechnical Standardization (CENELEC).
Information Technology Equipment - Safety - Part 1 : General Requirements.
- d) IEC 60950-1, The International Electrotechnical Commission (IEC).
Information Technology Equipment - Safety - Part 1 : General Requirements

7-2. Environment

- a) RoHS, Directive 2011/65/EU of the European Parliament and of the council of 8 June 2011

Product Specification

8. Packing

8-1. Designation of Lot Mark

a) Lot Mark

| | | | | | | | | | | | | |
|---|---|---|---|---|---|---|---|---|---|---|---|---|
| A | B | C | D | E | F | G | H | I | J | K | L | M |
|---|---|---|---|---|---|---|---|---|---|---|---|---|

A,B,C : SIZE(INCH)
E : MONTH

D : YEAR
F ~ M : SERIAL NO.

Note

1. YEAR

| | | | | | | | | | | |
|------|------|------|------|------|------|------|------|------|------|------|
| Year | 2011 | 2012 | 2013 | 2014 | 2015 | 2016 | 2017 | 2018 | 2019 | 2020 |
| Mark | A | B | C | D | E | F | G | H | J | K |

2. MONTH

| | | | | | | | | | | | | |
|-------|-----|-----|-----|-----|-----|-----|-----|-----|-----|-----|-----|-----|
| Month | Jan | Feb | Mar | Apr | May | Jun | Jul | Aug | Sep | Oct | Nov | Dec |
| Mark | 1 | 2 | 3 | 4 | 5 | 6 | 7 | 8 | 9 | A | B | C |

b) Location of Lot Mark

Serial No. is printed on the label. The label is attached to the backside of the LCD module.
This is subject to change without prior notice.

8-2. Packing Form

1) Package quantity in one box : 10 pcs

b) Box Size : 635mm X 370mm X 400mm

Product Specification**9. PRECAUTIONS**

Please pay attention to the followings when you use this TFT LCD module.

9-1. MOUNTING PRECAUTIONS

- (1) You must mount a module using holes arranged in four corners or four sides.
- (2) You should consider the mounting structure so that uneven force (ex. Twisted stress) is not applied to the module. And the case on which a module is mounted should have sufficient strength so that external force is not transmitted directly to the module.
- (3) Please attach the surface transparent protective plate to the surface in order to protect the polarizer. Transparent protective plate should have sufficient strength in order to resist external force.
- (4) You should adopt radiation structure to satisfy the temperature specification.
- (5) Acetic acid type and chlorine type materials for the cover case are not desirable because the former generates corrosive gas of attacking the polarizer at high temperature and the latter causes circuit break by electro-chemical reaction.
- (6) Do not touch, push or rub the exposed polarizers with glass, tweezers or anything harder than HB pencil lead. And please do not rub with dust clothes with chemical treatment. Do not touch the surface of polarizer for bare hand or greasy cloth. (Some cosmetics are detrimental to the polarizer.)
- (7) When the surface becomes dusty, please wipe gently with absorbent cotton or other soft materials like chamois soaks with petroleum benzene. Normal-hexane is recommended for cleaning the adhesives used to attach front / rear polarizers. Do not use acetone, toluene and alcohol because they cause chemical damage to the polarizer.
- (8) Wipe off saliva or water drops as soon as possible. Their long time contact with polarizer causes deformations and color fading.
- (9) Do not open the case because inside circuits do not have sufficient strength.
- (10) As The IPS panel is sensitive & slim, please recommend the metal frame of the system supports the panel by the double side-mount.

9-2. OPERATING PRECAUTIONS

- (1) The spike noise causes the mis-operation of circuits. It should be lower than following voltage :
 $V = \pm 200\text{mV}$ (Over and under shoot voltage)
- (2) Response time depends on the temperature. (In lower temperature, it becomes longer.)
- (3) Brightness depends on the temperature. (In Higher temperature, it becomes lower.)
And in lower temperature, response time (required time that brightness is stable after turned on) becomes longer.
- (4) Be careful for condensation at sudden temperature change. Condensation makes damage to polarizer or electrical contacted parts. And after fading condensation, smear or spot will occur.
- (5) When fixed patterns are displayed for a long time, remnant image is likely to occur.
- (6) Module has high frequency circuits. Sufficient suppression to the electromagnetic interference shall be done by system manufacturers. Grounding and shielding methods may be important to minimized the interference.
- (7) Please do not give any mechanical and/or acoustical impact to LCM. Otherwise, LCM can't be operated its full characteristics perfectly.
- (8) A screw which is fastened up the steels should be a machine screw.
(if not, it causes metallic foreign material and deal LCM a fatal blow)
- (9) Please do not set LCD on its edge.
- (10) When LCMs are used for public display defects such as Yogore, image sticking can not be guarantee.
- (11) LCMs cannot support "Interlaced Scan Method"
- (12) When this reverse model is used as a forward-type model (PCB on top side), LGD can not guarantee any defects of LCM.
- (13) Please conduct image sticking test after 2-hour aging with Rolling PTN and normal temperature (25~40°C)

9-3. ELECTROSTATIC DISCHARGE CONTROL

Since a module is composed of electronic circuits, it is not strong to electrostatic discharge. Make certain that treatment persons are connected to ground through wrist band etc. And don't touch interface pin directly.

9-4. PRECAUTIONS FOR STRONG LIGHT EXPOSURE

Strong light exposure causes degradation of polarizer and color filter.

9-5. STORAGE

When storing modules as spares for a long time, the following precautions are necessary.

- (1) Store them in a dark place. Do not expose the module to sunlight or fluorescent light. Keep the temperature between 5°C and 35°C at normal humidity.
- (2) The polarizer surface should not come in contact with any other object.
It is recommended that they be stored in the container in which they were shipped.

9-6. HANDLING PRECAUTIONS FOR PROTECTION FILM

- (1) The protection film is attached to the bezel with a small masking tape.
When the protection film is peeled off, static electricity is generated between the film and polarizer.
This should be peeled off slowly and carefully by people who are electrically grounded and with well ion-blown equipment or in such a condition, etc.
- (2) When the module with protection film attached is stored for a long time, sometimes there remains a very small amount of glue still on the bezel after the protection film is peeled off.
- (3) You can remove the glue easily. When the glue remains on the bezel surface or its vestige is recognized, please wipe them off with absorbent cotton waste or other soft material like chamois soaked with normal-hexane.

Product Specification

SPECIFICATION FOR APPROVAL

(●) Preliminary Specification
() Final Specification

| | |
|-------|-------------------|
| Title | 23.8" UHD TFT LCD |
|-------|-------------------|

| | |
|-------|---------|
| BUYER | GENERAL |
| MODEL | |

| | |
|----------|----------------------|
| SUPPLIER | LG Display Co., Ltd. |
| *MODEL | LM238WR3 |
| SUFFIX | SSB1 |

*When you obtain standard approval, please use the above model name without suffix

| APPROVED BY | SIGNATURE DATE |
|-------------|----------------|
| / | _____ |
| / | _____ |
| / | _____ |

Please return 1 copy for your confirmation with your signature and comments.

| APPROVED BY | SIGNATURE DATE |
|-------------------------|----------------|
| W.G. Kweon / G.Manager | _____ |
| REVIEWED BY | |
| K.H. Hwang/ Manager [C] | _____ |
| S.Y. An / Manager [M] | _____ |
| G.S. Kim / Manager [O] | _____ |
| T.H. Shin / Manager [P] | _____ |
| PREPARED BY | |
| S.Y. Kim / Engineer | _____ |

Product Engineering Dept.
LG Display Co., Ltd

Product Specification
Contents

| No | ITEM | Page |
|-----|---|------|
| | COVER | 1 |
| | CONTENTS | 2 |
| | RECORD OF REVISIONS | 3 |
| 1 | GENERAL DESCRIPTION | 4 |
| 2 | ABSOLUTE MAXIMUM RATINGS | 5 |
| 3 | ELECTRICAL SPECIFICATIONS | 6 |
| 3-1 | ELECTRICAL CHARACTERISTICS | 6 |
| 3-2 | INTERFACE CONNECTIONS | 9 |
| 3-3 | eDP SIGNAL SPECIFICATIONS | 11 |
| 3-4 | SIGNAL TIMING SPECIFICATIONS | 15 |
| 3-5 | SIGNAL TIMING WAVEFORMS | 16 |
| 3-6 | COLOR INPUT DATA REFERNECE | 17 |
| 3-7 | POWER SEQUENCE & DIP CONDITION FOR LCD MODULE | 18 |
| 4 | OPTICAL SPECIFICATIONS | 20 |
| 5 | MECHANICAL CHARACTERISTICS | 26 |
| 6 | RELIABILITY | 29 |
| 7 | INTERNATIONAL STANDARDS | 30 |
| 7-1 | SAFETY | 30 |
| 7-2 | ENVIRONMENT | 30 |
| 8 | PACKING | 31 |
| 8-1 | DESIGNATION OF LOT MARK | 31 |
| 8-2 | PACKING FORM | 31 |
| 9 | PRECAUTIONS | 32 |
| 9-1 | MOUNTING PRECAUTIONS | 32 |
| 9-2 | OPERATING PRECAUTIONS | 32 |
| 9-3 | ELECTROSTATIC DISCHARGE CONTROL | 33 |
| 9-4 | PRECAUTIONS FOR STRONG LIGHT EXPOSURE | 33 |
| 9-5 | STORAGE | 33 |
| 9-6 | HANDLING PRECAUTIONS FOR PROTECTION FILM | 33 |

Product Specification

1. General Description

LM238WR3 is a Color Active Matrix Liquid Crystal Display with a Light Emitting Diode (LED) backlight Assembly without LED driver. The matrix employs a-Si Thin Film Transistor as the active element. It is a transmissive type display operating in the normally black mode. It has a 23.8 inch diagonally measured active display area with UHD resolution (3840 horizontal by 2160 vertical pixel array) Each pixel is divided into Red, Green and Blue sub-pixels or dots which are arranged in vertical stripes. Gray scale or the brightness of the sub-pixel color is determined with a 10-bit gray scale signal for each dot, thus, presenting a palette of more than 1.07Billion colors with A-FRC (Advanced Frame Rate Control). It has been designed to apply eDP interface. It is intended to support displays where high brightness, super wide viewing angle, high color saturation, and high color are important.

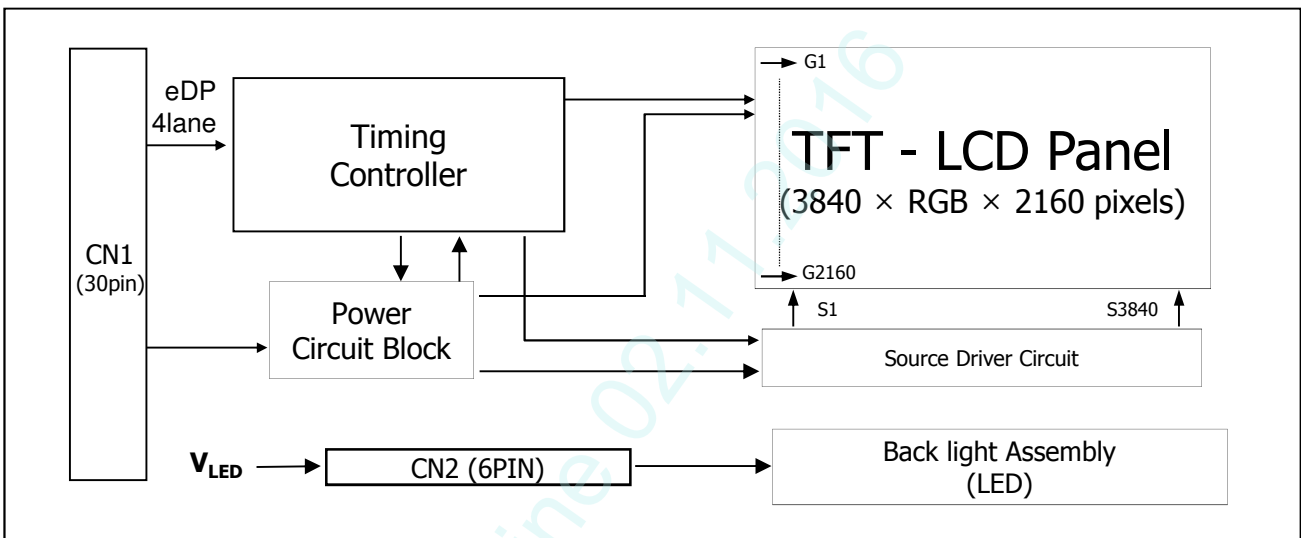

[FIG.1] Block diagram

General Features

| | |
|------------------------|---|
| Active Screen Size | 23.8 inches(60.31cm) (Aspect ratio 16:9) |
| Outline Dimension | 536.3(H) x 313.9(V) x 12.9(D) mm (Typ.) |
| Pixel Pitch | 0.13690 mm x 0.13690 mm |
| Pixel Format | 3840 horiz. By 2160 vert. Pixels RGB stripes arrangement |
| Color Depth | 1.07 Billion colors, 10Bit (8Bit + A-FRC) |
| Luminance, White | 350 cd/m ² (Center 1 Point, Typ.) |
| Viewing Angle(CR>10) | View Angle Free (R/L 178(Typ.), U/D 178(Typ.)) |
| Power Consumption | Total 25.7 Watt (6.3 Watt @VLCD 19.4 Watt @Is=120mA) |
| Weight | Typ : 1610g, Max : 1690g |
| Display Operating Mode | Transmissive mode, normally black |
| Panel type | Reverse type |
| Concept | 3-side borderless |
| Surface Treatment | Advanced Anti-glare treatment of the front polarizer (3H) |

Product Specification

2. Absolute Maximum Ratings

The following are maximum values which, if exceeded, may cause faulty operation or damage to the unit.

Table 1. ABSOLUTE MAXIMUM RATINGS

| Parameter | Symbol | Values | | Units | Notes |
|----------------------------|--------|--------|-----|-------|-------------|
| | | Min | Max | | |
| Power Input Voltage | VLCD | -0.3 | 12 | Vdc | at 25 ± 2°C |
| Operating Temperature | TOP | 0 | 50 | °C | 1, 2, 3 |
| Storage Temperature | TST | -20 | 60 | °C | |
| Operating Ambient Humidity | HOP | 10 | 90 | %RH | |
| Storage Humidity | HST | 10 | 90 | %RH | |

- Note : 1. Temperature and relative humidity range are shown in the figure below.
 Wet bulb temperature should be 39 °C Max, and no condensation of water.
 2. Maximum Storage Humidity is up to 40°C, 70% RH only for 4 corner light leakage Mura.
 3. Storage condition is guaranteed under packing condition
 4. LCM Surface Temperature should be Min. 0°C and Max. 65°C under the VLCD=10V, fV=60Hz, 25°C ambient Temp. no humidity control and LED string current is typical value.

FIG.2 Temperature and relative humidity

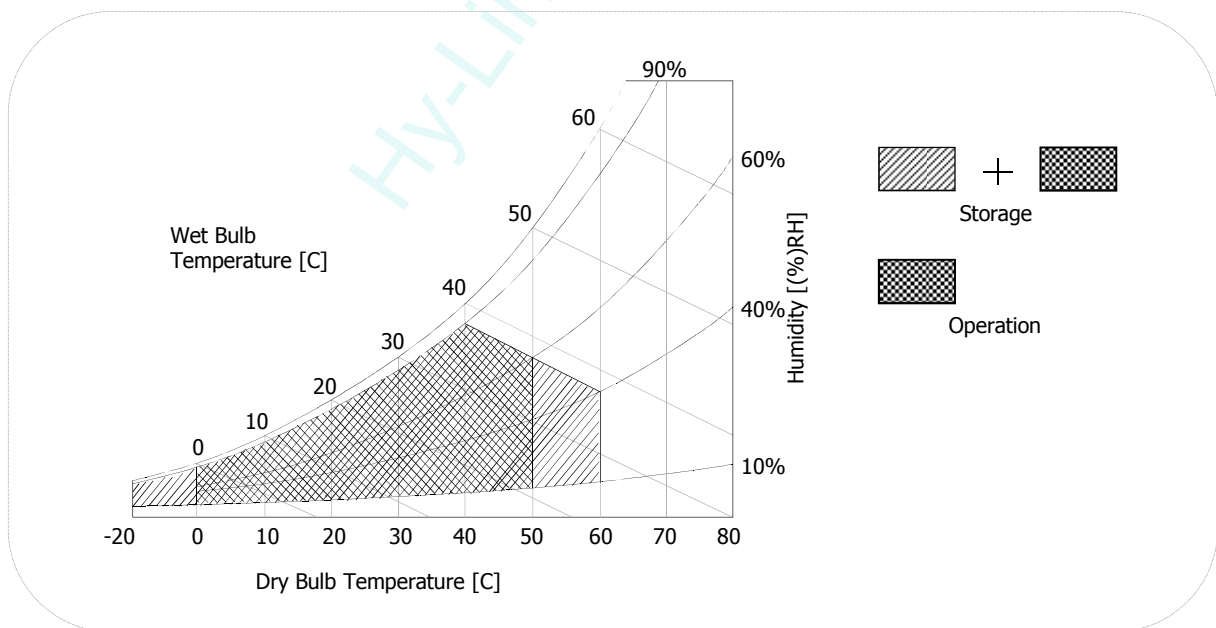

Product Specification
3. Electrical Specifications
3-1. Electrical Characteristics

It requires two power inputs. One is employed to power the LCD electronics and to drive the TFT array and liquid crystal. The second input power for the LED/Backlight, is typically generated by a LED Driver. The LED Driver is an external unit to the LCDs.

Table 2-1. ELECTRICAL CHARACTERISTICS

| Parameter | Symbol | Values | | | Unit | Notes |
|-------------------------------|---------------------|--------|------|------|-------------------|-------|
| | | Min | Typ | Max | | |
| MODULE : | | | | | | |
| Power Supply Input Voltage | V _{LCD} | 9.5 | 10.0 | 10.5 | Vdc | 5 |
| Permissive Power Input Ripple | V _{ripple} | | | 400 | mV _{p-p} | 1 |
| Power Supply Input Current | I _{LCD} | - | 630 | 788 | mA | 2 |
| | | - | 840 | 1050 | mA | 3 |
| Power Consumption | P _c TYP | - | 6.3 | 7.88 | Watt | 2 |
| | P _c MAX | - | 8.4 | 10.5 | Watt | 3 |
| Rush current | I _{RUSH} | - | | 3 | A | 4 |

Note :

1. Permissive power ripple should be measured under V_{LCD}=10.0V, 25°C, f_V=60Hz condition and at that time, we recommend the bandwidth configuration of oscilloscope is to be under 20Mhz.
2. The specified current and power consumption are under the V_{LCD}=10.0V, 25°C, f_V=60Hz condition whereas mosaic pattern(8 x 6) is displayed and f_V is the frame frequency.
3. The current is specified at the maximum current pattern.
4. Maximum Condition of Inrush current :
The duration of rush current is about 2ms and rising time of power Input is 1ms(min.).
5. V_{LCD} level must be measured at two points on LCM PCB - between V_{LCD} (test point) and LCM Ground. The measured results need to meet the Power supply input voltage specification.
(Test condition : maximum power pattern , 25°C, fV=60Hz)

Product Specification

- **Permissive Power input ripple** ($V_{LCD} = 10.0V$, $25^{\circ}C$, f_v (frame frequency)=MAX condition)

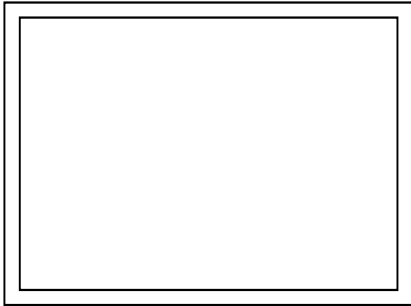

White pattern



Black pattern

- **Power consumption** ($V_{LCD} = 10V$, $25^{\circ}C$, f_v (frame frequency)=60Hz condition)

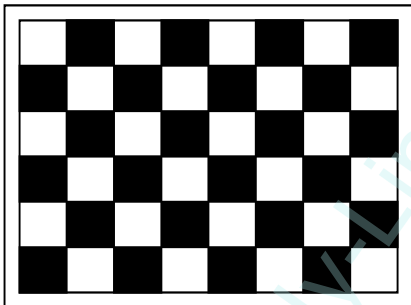

Typical power Pattern

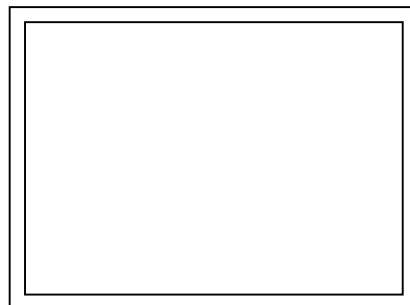

Maximum power Pattern

FIG.3 Mosaic pattern & White Pattern for power consumption measurement

Product Specification
Table 2-2. ELECTRICAL CHARACTERISTICS of LED bar

| Parameter | Symbol | Values | | | Unit | Notes |
|--------------------|--------|--------|--------|--------|------|---------|
| | | Min. | Typ. | Max. | | |
| LED String Current | Is | - | (120) | (125) | mA | 1, 2, 5 |
| LED String Voltage | Vs | (50.3) | (54.0) | (57.6) | V | 1, 5 |
| Power Consumption | PBar | - | (19.4) | (20.8) | Watt | 1, 2, 4 |
| LED Life Time | LED_LT | 30,000 | - | - | Hrs | 3 |

Notes) The LED Bar consists of 54 LED packages, 3 strings (parallel) x 18packages (serial) x 1 bar

LED driver design guide

: The design of the LED driver must have specifications for the LED in LCD Assembly.

The performance of the LED in LCM, for example life time or brightness, is extremely influenced by the characteristics of the LED driver.

So all the parameters of an LED driver should be carefully designed and output current should be Constant current control.

Please control feedback current of each string individually to compensate the current variation among the strings of LEDs.

When you design or order the LED driver, please make sure unwanted lighting caused by the mismatch of the LED and the LED driver (no lighting, flicker, etc) never occurs.

When you confirm it, the LCD module should be operated in the same condition as installed in your instrument.

1. The specified values are for a single LED bar.
2. The specified current is defined as the input current for a single LED string with 100% duty cycle.
3. The LED life time is defined as the time when brightness of LED packages become 50% or less than the initial value under the conditions at $T_a = 25 \pm 2^\circ\text{C}$ and LED string current is typical value.
4. The power consumption shown above does not include loss of external driver.
 The typical power consumption is calculated as $P_{\text{Bar}} = V_s(\text{Typ.}) \times I_s(\text{Typ.}) \times \text{No. of strings}$.
 The maximum power consumption is calculated as $P_{\text{Bar}} = V_s(\text{Max.}) \times I_s(\text{Typ.}) \times \text{No. of strings}$.
5. LED operating conditions are must not exceed Max. ratings.

Product Specification
3-2. Interface Connections
Table 3. MODULE CONNECTOR(CN1) PIN CONFIGURATION

| Pin | Symbol | Description | Notes |
|-----|---------|---|--|
| 1 | VIN | Power Supply +10.0V | <p>[Connector] GT05Q-30S-H10-MN, LSMtron, 30pin, 0.5pitch or equivalent</p> <p>[Mating Connector] 20453-030T-01, I-Pex series or equivalent</p> <p>[Connector pin arrangement]</p>  |
| 2 | VIN | Power Supply +10.0V | |
| 3 | VIN | Power Supply +10.0V | |
| 4 | VIN | Power Supply +10.0V | |
| 5 | VIN | Power Supply +10.0V | |
| 6 | NC | No Connection | |
| 7 | GND | Ground | |
| 8 | NC | Reserved for LCD manufacture's use | |
| 9 | NC | Reserved for LCD manufacture's use | |
| 10 | GND | Ground | |
| 11 | HPD | Hot Plug Detect Signal | |
| 12 | GND | Ground | |
| 13 | AUX_CHN | Component Signal for Auxiliary Channel | |
| 14 | AUX_CHP | True Signal for Auxiliary Channel | |
| 15 | GND | Ground | |
| 16 | Lane0P | True Signal for Main Link 0 | |
| 17 | Lane0N | Component Signal for Main Link 0 | |
| 18 | GND | Ground | |
| 19 | Lane1P | True Signal for Main Link 1 | |
| 20 | Lane1N | Component Signal for Main Link 1 | |
| 21 | GND | Ground | |
| 22 | Lane2P | True Signal for Main Link 2 | |
| 23 | Lane2N | Component Signal for Main Link 2 | |
| 24 | GND | Ground | |
| 25 | Lane3P | True Signal for Main Link 3 | |
| 26 | Lane3N | Component Signal for Main Link 3 | |
| 27 | GND | Ground | |
| 28 | BIST | L(GND): Black, H(3.3V): Rotational Pattern | |
| 29 | NC | No Connection | |
| 30 | GND | Ground | |

Product Specification

3-2-2. BACKLIGHT CONNECTOR PIN CONFIGURATION(CN2)

- Connector : SM06B-SHJH (HF) (Manufactured by JST) or Yeonho
- Mating Connector : SHJP-06V-S(HF) or SHJP-06V-A-K(HF) or Equivalent

Table 4. LED CONNECTOR PIN CONFIGURATION

| Pin | Symbol | Description |
|-----|--------|---------------------------|
| 1 | FB1 | Channel1 Current Feedback |
| 2 | NC | No Connection |
| 3 | VLED | LED Power Supply |
| 4 | VLED | LED Power Supply |
| 5 | FB2 | Channel2 Current Feedback |
| 6 | FB3 | Channel3 Current Feedback |

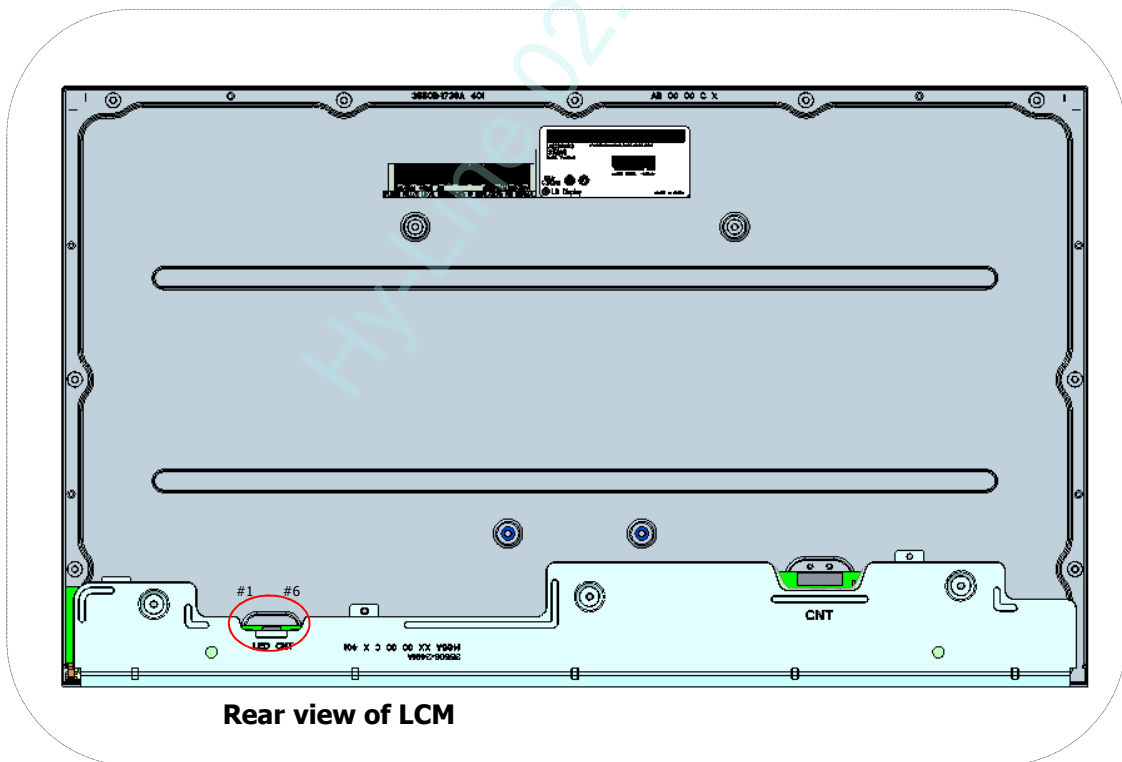

[Figure 4] Backlight connector view

Product Specification

Note6) Definition of Differential Voltage

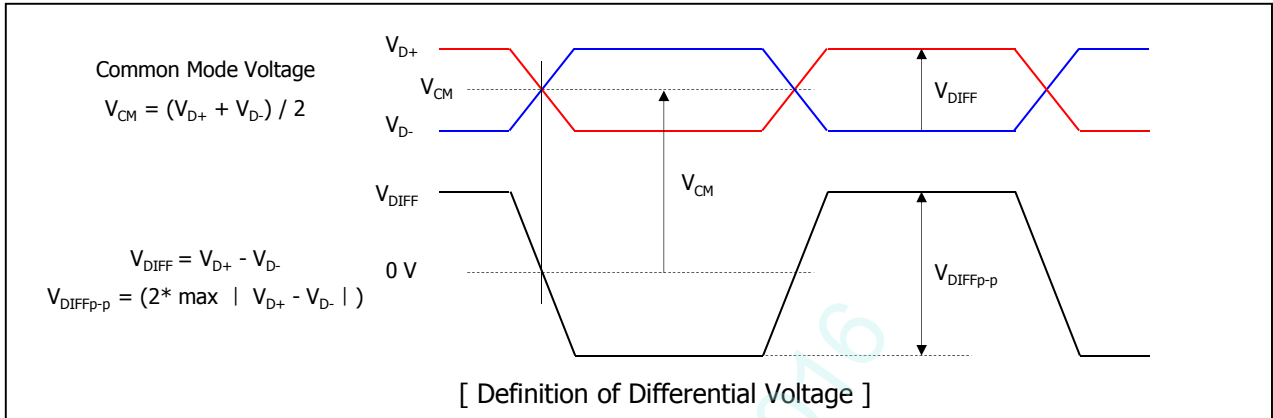

Note7) Main Link EYE Diagram

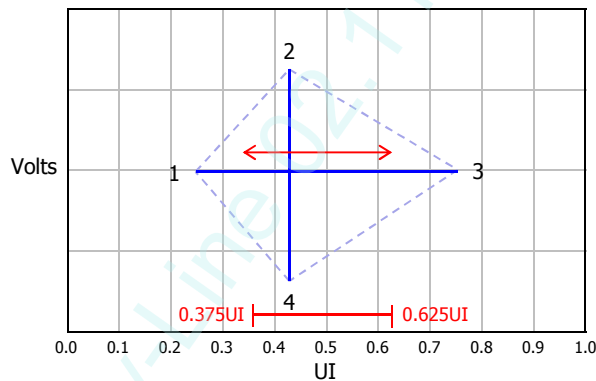

| Point | High Bit Rate 2 @ TP3 EQ | |
|-------|--|------------|
| | Time(UI) | Voltage(V) |
| 1 | Any UI location (x) where the eye width is open from x to x+0.38UI | 0.000 |
| 2 | Any passing UI location between 0.375UI-0.625UI | 0.045 |
| 3 | Point 1 + 0.38UI | 0.000 |
| 4 | Same as Point 2 | -0.045 |

[EYE Mask Vertices at embedded DP Sink Connector Pins]

Product Specification

3-3-2. eDP AUX Channel Signal

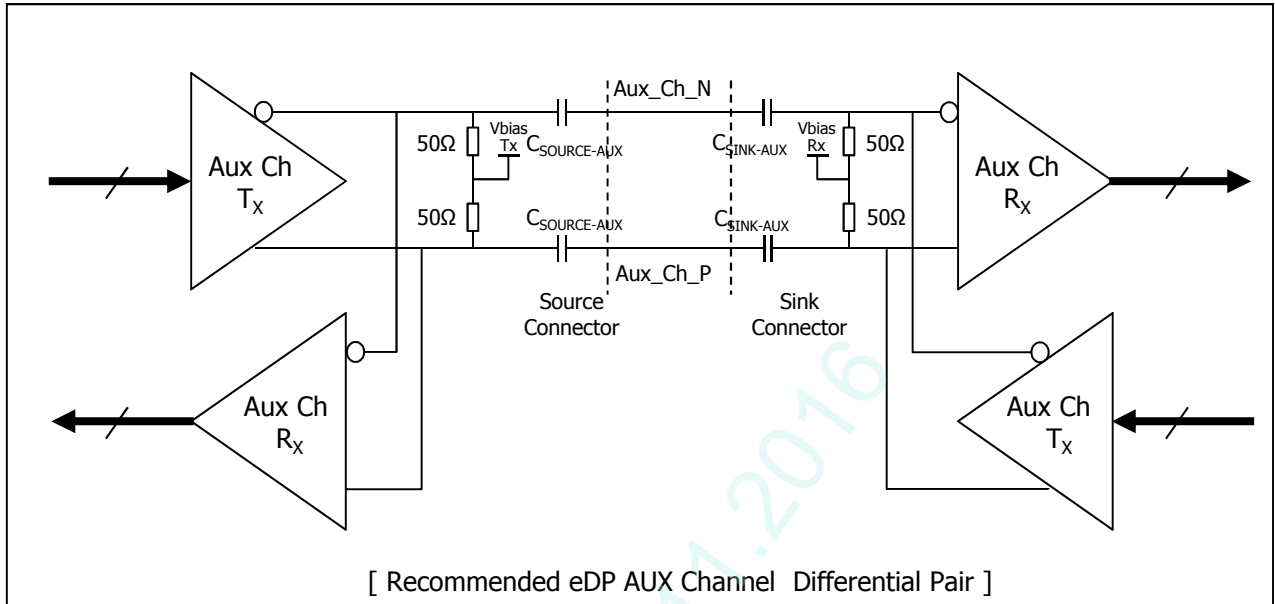

| Parameter | Symbol | Min | Typ | Max | Unit | Notes |
|--|-------------------|------|------|------|------|---------------|
| AUX Unit Interval | UI | 0.4 | - | 0.6 | us | |
| AUX Jitter at Tx IC Package Pins | T_{jitter} | - | - | 0.04 | UI | Equal to 24ns |
| AUX Jitter at Rx IC Package Pins | | - | - | 0.05 | UI | Equal to 30ns |
| AUX Peak-to-peak voltage at Connector Pins of Receiving | $V_{AUX-DIFFp-p}$ | 0.32 | - | 1.36 | V | |
| AUX Peak-to-peak voltage at Connector Pins of Transmitting | | 0.39 | - | 1.38 | V | |
| AUX EYE width at Connector Pins of Tx and Rx | | 0.98 | - | - | UI | |
| AUX DC common mode voltage | V_{AUX-CM_Rx} | - | 0 | 2.0 | V | |
| | V_{AUX-CM_Tx} | - | 0.15 | 2.0 | V | |
| AUX AC Coupling Capacitor | $C_{SOURCE-AUX}$ | 75 | | 200 | nF | Source side |

Note)

1. Termination resistor is typically integrated into the transmitter and receiver implementations.
2. $V_{AUX-DIFFp-p} = 2 * | V_{AUXP} - V_{AUXN} |$
3. Termination resistor should be $\pm 50\Omega$ at source side to AUX level.
4. At sink side AUX cap. are for protection ESD/EOS damage.
5. Mismatched common mode voltage will occur abnormal display.

Product Specification

3-3-3. eDP HPD Signal

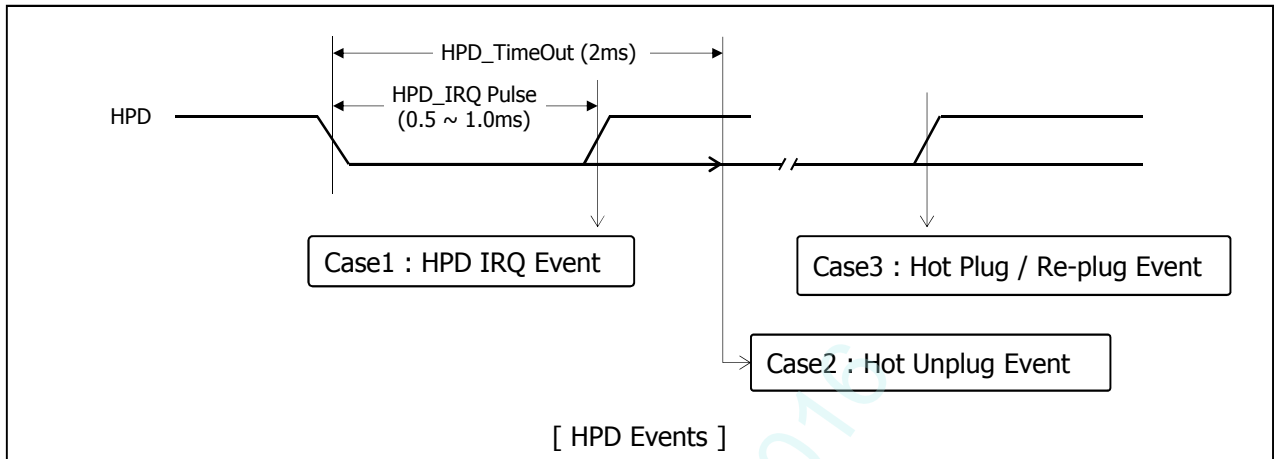

| Parameter | Symbol | Min | Typ | Max | Unit | Notes |
|--------------------------------|---------|------|-----|-----|------|-----------------------|
| HPD Voltage | HPD | 2.25 | - | 3.6 | V | Sink side Driving |
| Hot Plug Detection Threshold | | 2.0 | - | - | V | Source side Detecting |
| Hot Unplug Detection Threshold | | - | - | 0.8 | V | |
| HPD_IRQ Pulse Width | HPD_IRQ | 0.5 | - | 1.0 | ms | |
| HPD_TimeOut | | 2.0 | - | - | ms | HPD Unplug Event |

Note)

1. HPD IRQ : Sink device wants to notify the Source device that Sink's status has changed so it toggles HPD line, forcing the Source device to read its Link / Sink Receiver DPCD field via the AUX-CH
2. HPD Unplug : The Sink device is no longer attached to the Source device and the Source device may then disable its Main Link as a power saving mode
3. Plug / Re-plug : The Sink device is now attached to the Source device, forcing the Source device to read its Receiver capabilities and Link / Sink status Receiver DPCD fields via the AUX-CH

Product Specification
3-4. Signal Timing Specifications

All of the interface signal timing should be satisfied with the following specifications for it's proper operation.

Table 5. TIMING TABLE

| ITEM | | SYMBOL | Min | Typ | Max | Unit | Note |
|-------------|------------------------|--------|--------|--------|--------|------|-----------------|
| DCLK | Period | tCLK | 1.82 | 1.875 | 1.93 | ns | |
| | Frequency | fCLK | 518.25 | 533.25 | 548.25 | MHz | - |
| Hsync | Period | tHP | 3968 | 4000 | 4040 | tCLK | |
| | Width-Active | tWH | 28 | 32 | 36 | | |
| Vsync | Period | tVP | 2220 | 2222 | 2268 | tHP | |
| | Frequency | fV | 58.2 | 59.997 | 61.68 | Hz | |
| | Width-Active | tWV | 5 | 5 | 5 | tHP | |
| Data Enable | Horizontal Valid | tHV | 3840 | 3840 | 3840 | tCLK | |
| | Horizontal Back Porch | tHBP | 52 | 80 | 116 | | |
| | Horizontal Front Porch | tHFP | 48 | 48 | 48 | | |
| | Horizontal Blank | - | 128 | 160 | 200 | | tWH+ tHBP+ tHFP |
| | Vertical Valid | tVV | 2160 | 2160 | 2160 | tHP | |
| | Vertical Back Porch | tVBP | 52 | 54 | 100 | | |
| | Vertical Front Porch | tVFP | 3 | 3 | 3 | | |
| | Vertical Blank | - | 60 | 62 | 108 | | tWV+ tVBP+ tVFP |

Note:

1. DE Only mode operation. The input of Hsync & Vsync signal does not have an effect on LCD normal operation.
2. The performance of the electro-optical characteristics may be influenced by variance of the vertical refresh rates.
3. Horizontal period should be even.

Product Specification

3-5. Signal Timing Waveforms

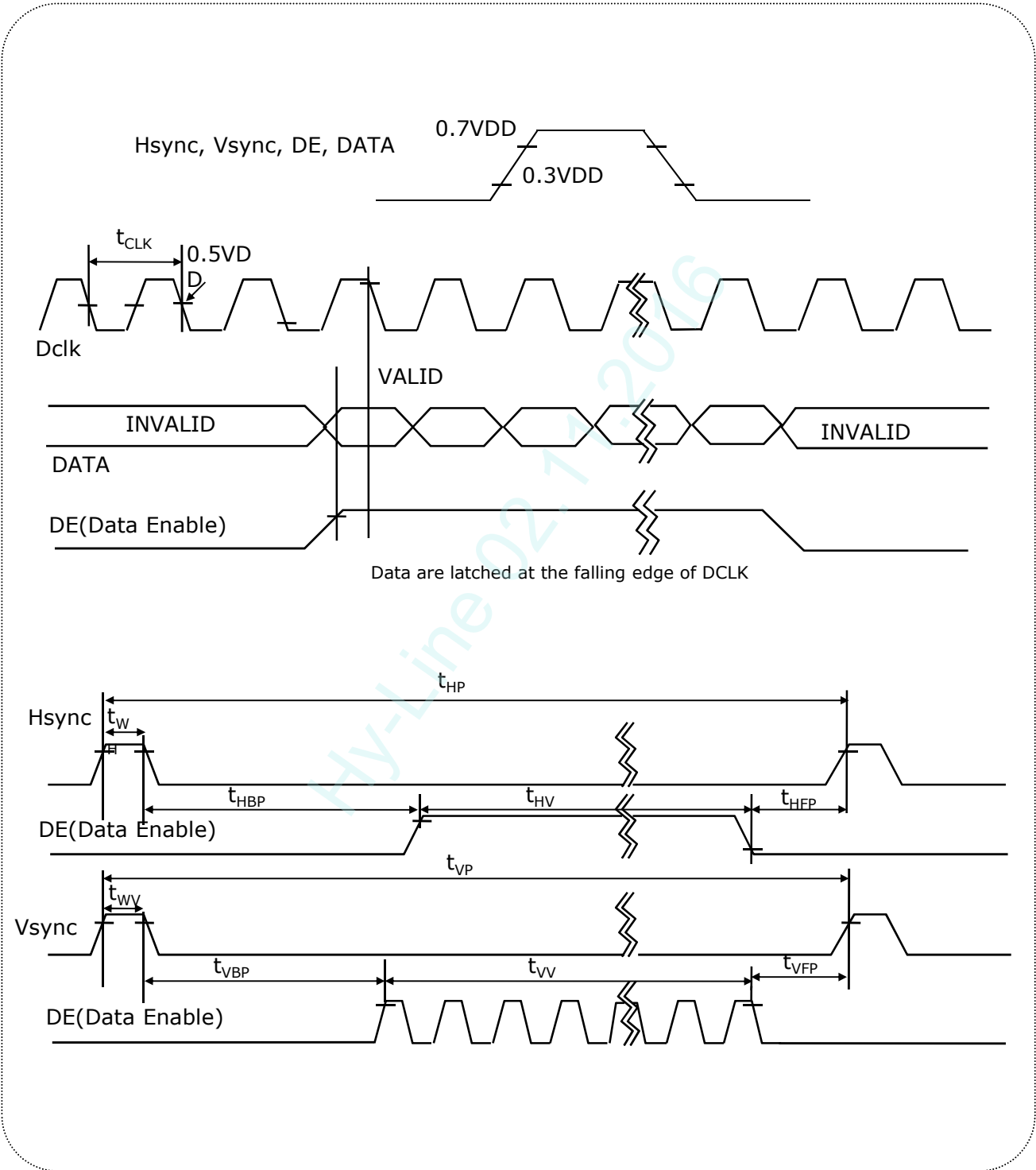

Product Specification
3-6. Color Input Data Reference

The Brightness of each primary color(red,green,blue) is based on the 10-bit gray scale data input for the color; the higher the binary input, the brighter the color. The table below provides a reference for color versus data input.

Table 6. COLOR DATA REFERENCE

| Color | | Input Color Data | | | | | | | | | | | | | | | | | | | | | | | | | | | | | |
|-------------|--------------|------------------|----|----|----|----|-----|----|----|----|----|-------|----|----|----|----|-----|----|----|----|----|------|----|----|----|----|-----|----|----|----|----|
| | | RED | | | | | | | | | | GREEN | | | | | | | | | | BLUE | | | | | | | | | |
| | | MSB | | | | | LSB | | | | | MSB | | | | | LSB | | | | | MSB | | | | | LSB | | | | |
| | | R9 | R8 | R7 | R6 | R5 | R4 | R3 | R2 | R1 | R0 | G9 | G8 | G7 | G6 | G5 | G4 | G3 | G2 | G1 | G0 | B9 | B8 | B7 | B6 | B5 | B4 | B3 | B2 | B1 | B0 |
| Basic Color | Black | 0 | 0 | 0 | 0 | 0 | 0 | 0 | 0 | 0 | 0 | 0 | 0 | 0 | 0 | 0 | 0 | 0 | 0 | 0 | 0 | 0 | 0 | 0 | 0 | 0 | 0 | 0 | 0 | 0 | 0 |
| | Red (1023) | 1 | 1 | 1 | 1 | 1 | 1 | 1 | 1 | 1 | 1 | 0 | 0 | 0 | 0 | 0 | 0 | 0 | 0 | 0 | 0 | 0 | 0 | 0 | 0 | 0 | 0 | 0 | 0 | 0 | 0 |
| | Green (1023) | 0 | 0 | 0 | 0 | 0 | 0 | 0 | 0 | 0 | 0 | 1 | 1 | 1 | 1 | 1 | 1 | 1 | 1 | 1 | 1 | 0 | 0 | 0 | 0 | 0 | 0 | 0 | 0 | 0 | 0 |
| | Blue (1023) | 0 | 0 | 0 | 0 | 0 | 0 | 0 | 0 | 0 | 0 | 0 | 0 | 0 | 0 | 0 | 0 | 0 | 0 | 0 | 0 | 1 | 1 | 1 | 1 | 1 | 1 | 1 | 1 | 1 | 1 |
| | Cyan | 0 | 0 | 0 | 0 | 0 | 0 | 0 | 0 | 0 | 0 | 1 | 1 | 1 | 1 | 1 | 1 | 1 | 1 | 1 | 1 | 1 | 1 | 1 | 1 | 1 | 1 | 1 | 1 | 1 | 1 |
| | Magenta | 1 | 1 | 1 | 1 | 1 | 1 | 1 | 1 | 1 | 1 | 0 | 0 | 0 | 0 | 0 | 0 | 0 | 0 | 0 | 0 | 1 | 1 | 1 | 1 | 1 | 1 | 1 | 1 | 1 | 1 |
| | Yellow | 1 | 1 | 1 | 1 | 1 | 1 | 1 | 1 | 1 | 1 | 1 | 1 | 1 | 1 | 1 | 1 | 1 | 1 | 1 | 1 | 0 | 0 | 0 | 0 | 0 | 0 | 0 | 0 | 0 | 0 |
| | White | 1 | 1 | 1 | 1 | 1 | 1 | 1 | 1 | 1 | 1 | 1 | 1 | 1 | 1 | 1 | 1 | 1 | 1 | 1 | 1 | 1 | 1 | 1 | 1 | 1 | 1 | 1 | 1 | 1 | 1 |
| RED | RED (000) | 0 | 0 | 0 | 0 | 0 | 0 | 0 | 0 | 0 | 0 | 0 | 0 | 0 | 0 | 0 | 0 | 0 | 0 | 0 | 0 | 0 | 0 | 0 | 0 | 0 | 0 | 0 | 0 | 0 | |
| | RED (001) | 0 | 0 | 0 | 0 | 0 | 0 | 0 | 0 | 0 | 0 | 0 | 0 | 0 | 0 | 0 | 0 | 0 | 0 | 0 | 0 | 0 | 0 | 0 | 0 | 0 | 0 | 0 | 0 | 0 | |
| | ... | ... | | | | | | | | | | ... | | | | | | | | | | ... | | | | | | | | | |
| | RED (1022) | 1 | 1 | 1 | 1 | 1 | 1 | 1 | 1 | 1 | 0 | 0 | 0 | 0 | 0 | 0 | 0 | 0 | 0 | 0 | 0 | 0 | 0 | 0 | 0 | 0 | 0 | 0 | 0 | 0 | 0 |
| | RED (1023) | 1 | 1 | 1 | 1 | 1 | 1 | 1 | 1 | 1 | 1 | 0 | 0 | 0 | 0 | 0 | 0 | 0 | 0 | 0 | 0 | 0 | 0 | 0 | 0 | 0 | 0 | 0 | 0 | 0 | 0 |
| GREEN | GREEN (000) | 0 | 0 | 0 | 0 | 0 | 0 | 0 | 0 | 0 | 0 | 0 | 0 | 0 | 0 | 0 | 0 | 0 | 0 | 0 | 0 | 0 | 0 | 0 | 0 | 0 | 0 | 0 | 0 | 0 | |
| | GREEN (001) | 0 | 0 | 0 | 0 | 0 | 0 | 0 | 0 | 0 | 0 | 0 | 0 | 0 | 0 | 0 | 0 | 0 | 0 | 0 | 0 | 0 | 0 | 0 | 0 | 0 | 0 | 0 | 0 | 0 | |
| | ... | ... | | | | | | | | | | ... | | | | | | | | | | ... | | | | | | | | | |
| | GREEN (1022) | 0 | 0 | 0 | 0 | 0 | 0 | 0 | 0 | 0 | 0 | 1 | 1 | 1 | 1 | 1 | 1 | 1 | 1 | 1 | 0 | 0 | 0 | 0 | 0 | 0 | 0 | 0 | 0 | 0 | 0 |
| | GREEN (1023) | 0 | 0 | 0 | 0 | 0 | 0 | 0 | 0 | 0 | 0 | 1 | 1 | 1 | 1 | 1 | 1 | 1 | 1 | 1 | 1 | 0 | 0 | 0 | 0 | 0 | 0 | 0 | 0 | 0 | 0 |
| BLUE | BLUE (000) | 0 | 0 | 0 | 0 | 0 | 0 | 0 | 0 | 0 | 0 | 0 | 0 | 0 | 0 | 0 | 0 | 0 | 0 | 0 | 0 | 0 | 0 | 0 | 0 | 0 | 0 | 0 | 0 | 0 | |
| | BLUE (001) | 0 | 0 | 0 | 0 | 0 | 0 | 0 | 0 | 0 | 0 | 0 | 0 | 0 | 0 | 0 | 0 | 0 | 0 | 0 | 0 | 0 | 0 | 0 | 0 | 0 | 0 | 0 | 0 | 1 | |
| | ... | ... | | | | | | | | | | ... | | | | | | | | | | ... | | | | | | | | | |
| | BLUE (1022) | 0 | 0 | 0 | 0 | 0 | 0 | 0 | 0 | 0 | 0 | 0 | 0 | 0 | 0 | 0 | 0 | 0 | 0 | 0 | 0 | 1 | 1 | 1 | 1 | 1 | 1 | 1 | 1 | 0 | 0 |
| | BLUE (1023) | 0 | 0 | 0 | 0 | 0 | 0 | 0 | 0 | 0 | 0 | 0 | 0 | 0 | 0 | 0 | 0 | 0 | 0 | 0 | 0 | 1 | 1 | 1 | 1 | 1 | 1 | 1 | 1 | 1 | 1 |

Product Specification

3-7. Power Sequence

3-7-1. Power Sequence

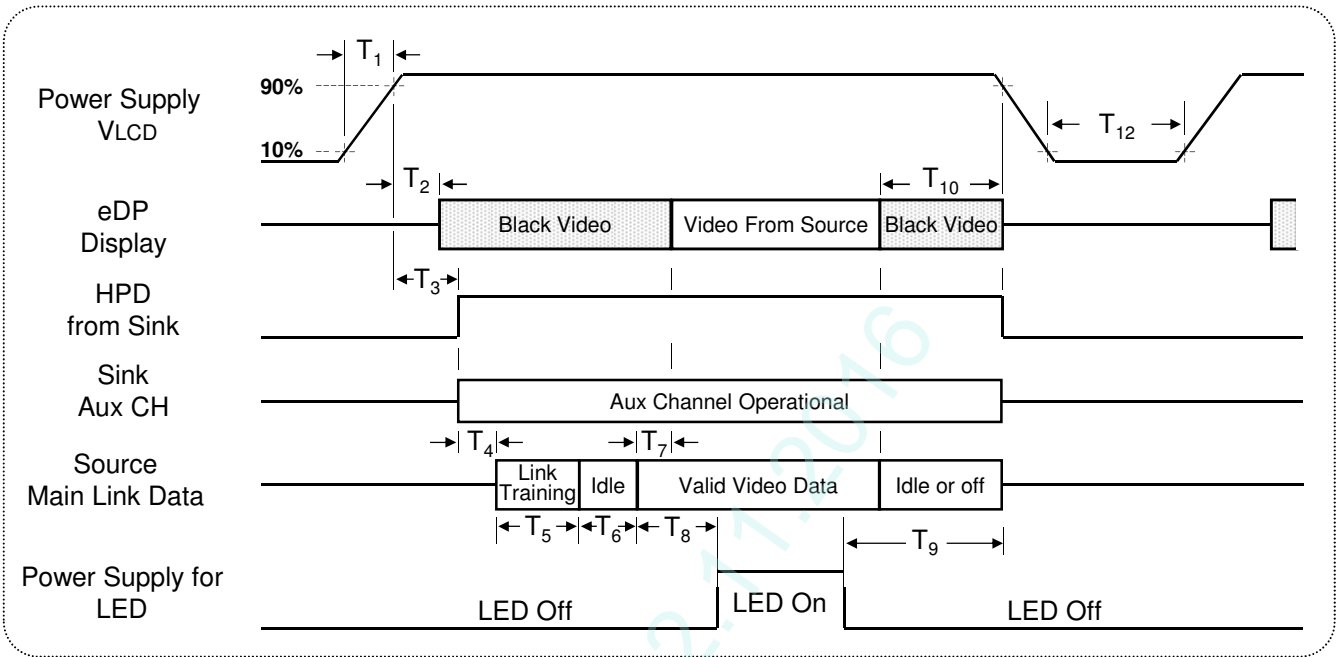

Table 7. POWER SEQUENCE TABLE

| Timing | Required By | Limits | | Units | Notes |
|----------------|-------------|--------|-----|-------|-------|
| | | Min | Max | | |
| T ₁ | Source | 0.5 | 10 | ms | - |
| T ₂ | Sink | 10 | 200 | ms | - |
| T ₃ | Sink | 15 | 200 | ms | - |
| T ₄ | Source | - | - | ms | 6 |
| T ₅ | Source | - | - | ms | 6 |
| T ₆ | Source | - | 100 | ms | - |
| T ₇ | Sink | 0 | 50 | ms | - |
| T ₈ | Source | 200 | - | ms | |
| T ₉ | Source | 200 | - | ms | 7 |

| Timing | Required By | Limits | | Units | Notes |
|-----------------|-------------|--------|-----|-------|-------|
| | | Min | Max | | |
| T ₁₀ | Source | 0 | 500 | ms | - |
| T ₁₂ | Source | 1000 | - | ms | |

- Note) 1. Do not insert the mating cable when system turn on.
 2. Valid Data have to meet "3-3. Signal Timing Specifications"
 3. When the Video signal is invalid, be sure to pull down the power supply for LCD VLCD to 0V.
 4. The above power sequence should be satisfied the basic power on/off and resolution, timing transition.
 5. LED power must be turn on after power supply for LCD and valid status of Video Signal.
 6. Link training duration is dependent on the customer's system.
 7. LED power must be turned off while Video data signal is valid

Product Specification

3-7-2. V_{LCD} Power Dip Condition

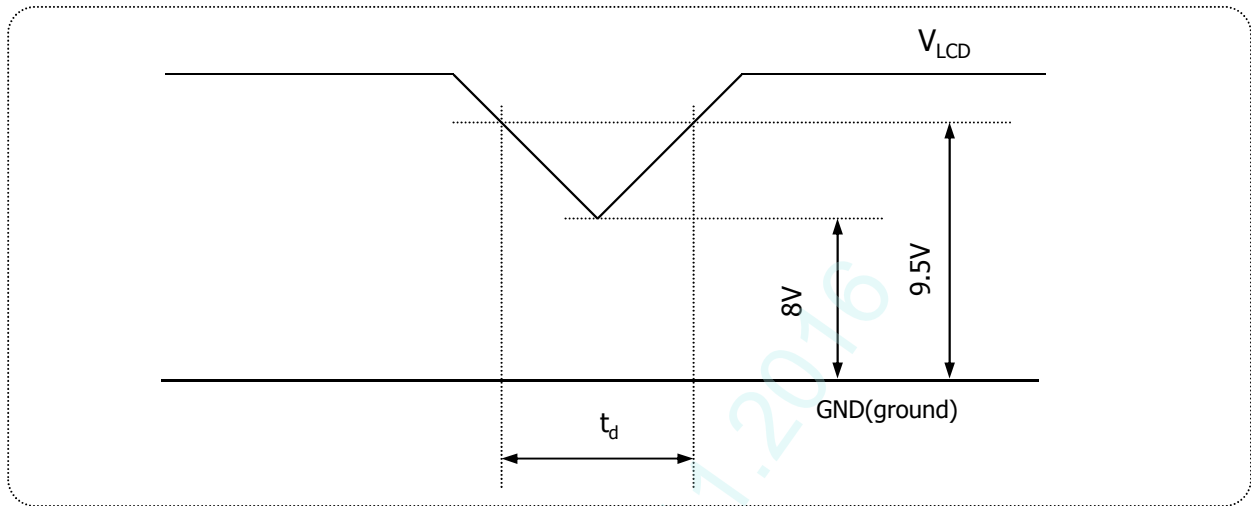

FIG.5 Power dip condition

1) Dip condition

$$8V \leq V_{LCD} < 9.5V, t_d \leq 20ms$$

2) $V_{LCD} < 8V$

V_{LCD} -dip conditions should also follow the Power On/Off conditions for supply voltage.

Product Specification

4. Optical Specifications

Optical characteristics are determined after the unit has been 'ON' for approximately 30 minutes in a dark environment at $25 \pm 2^\circ\text{C}$. The values specified are at an approximate distance 50cm from the LCD surface at a viewing angle of Φ and θ equal to 0° and aperture 1 degree.

FIG. 6 presents additional information concerning the measurement equipment and method.

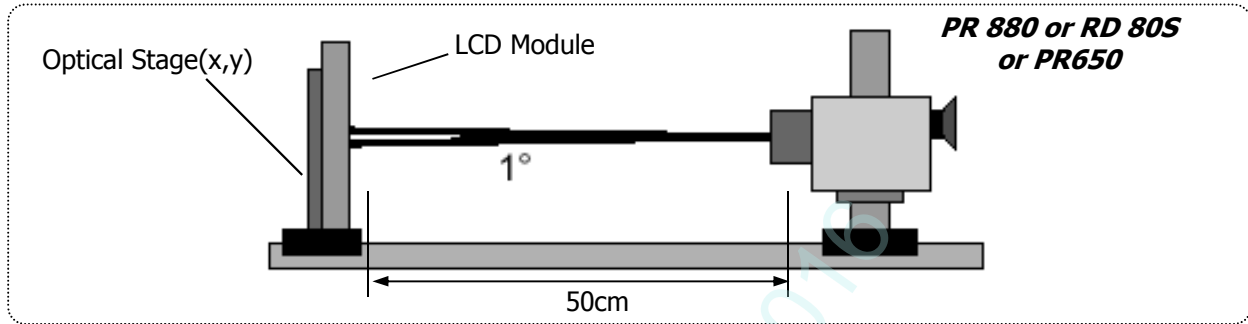

FIG.6 Optical Characteristic Measurement Equipment and Method

Table 8. OPTICAL CHARACTERISTICS

($T_a=25^\circ\text{C}$, $V_{LCD}=10\text{V}$, $f_v=60\text{Hz}$ Dclk=533.25MHz) $I_s=120\text{mA}$

| Parameter | Symbol | Values | | | Units | Notes | |
|--|------------------|-------------------|--------|-------|-------------------|--------|---|
| | | Min | Typ | Max | | | |
| Contrast Ratio | CR | (910) | (1300) | - | | 1 | |
| Surface Luminance, white | L_{WH} | 280 | 350 | - | cd/m ² | 2 | |
| Luminance Variation | δ_{WHITE} | 75 | - | - | % | 3 | |
| Response Time | Gray To Gray | T_{GTG_AVR} | - | 14 | 25 | ms | 4 |
| Color Coordinates [CIE1931] (By PR650) | RED | R_x | | TBD | | | |
| | | R_y | | TBD | | | |
| | GREEN | G_x | | TBD | | | |
| | | G_y | Typ | TBD | Typ | | |
| | BLUE | B_x | -0.03 | TBD | +0.03 | | |
| | | B_y | | TBD | | | |
| | WHITE | W_x | | 0.313 | | | |
| | W_y | | 0.329 | | | | |
| Color Shift | Horizontal | θ_{CST_H} | - | 178 | - | Degree | 5 |
| | Vertical | θ_{CST_V} | - | 178 | - | | |
| Viewing Angle (CR>10) | | | | | | | |
| General | Horizontal | θ_H | 170 | 178 | - | Degree | 6 |
| | Vertical | θ_V | 170 | 178 | - | | |
| Gray Scale | | - | | 2.2 | | 7 | |

Product Specification

Notes

1. Contrast Ratio(CR) is defined mathematically as : **(By PR880)**

$$\text{Contrast Ratio} = \frac{\text{Surface Luminance with all white pixels}}{\text{Surface Luminance with all black pixels}}$$

It is measured at center point(Location P1)

2. Surface luminance(L_{WH}) is luminance value at Center 1 point(P1) across the LCD surface 50cm from the surface with all pixels displaying white. For more information see FIG.7 (By PR880)

3. The variation in surface luminance , δ WHITE is defined as : **(By PR880)**

$$\delta_{\text{WHITE}} = \frac{\text{Minimum}(L_{P1}, L_{P2}, \dots, L_{P9})}{\text{Maximum}(L_{P1}, L_{P2}, \dots, L_{P9})} \times 100$$

Where L1 to L9 are the luminance with all pixels displaying white at 9 locations.
For more information see FIG.7

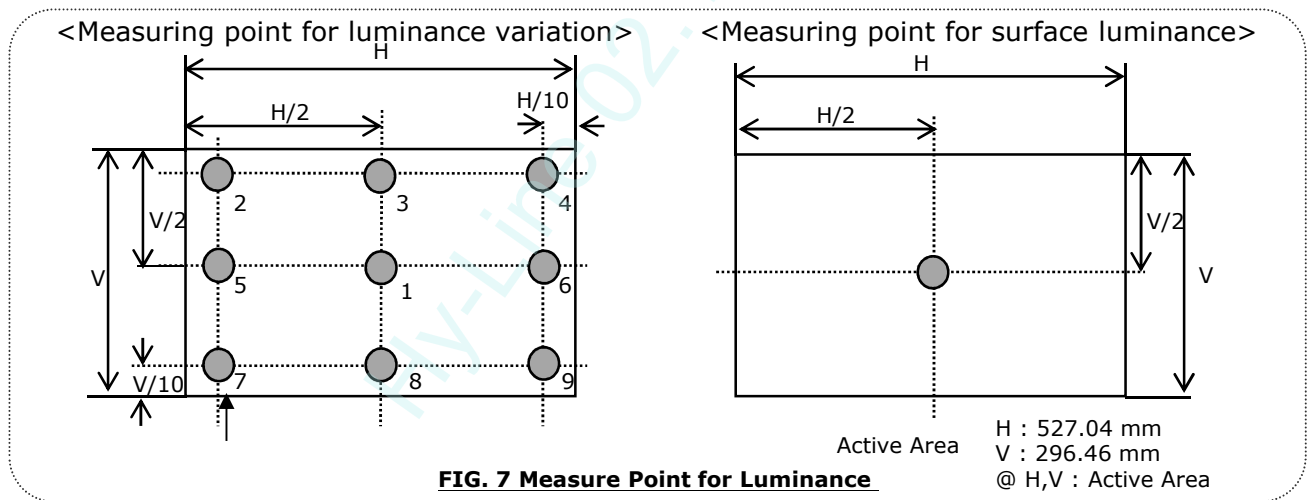

Product Specification

4. Gray to gray response time is the time required for the display to transition from gray to gray. For additional information see Table 9. **(By PR880)**

Table 9. Gray to gray response time table

| Gray to Gray | | Rising Time | | | | |
|--------------|-------|-------------|------|------|------|----|
| | | G1023 | G767 | G511 | G255 | G0 |
| Falling Time | G1023 | | | | | |
| | G767 | | | | | |
| | G511 | | | | | |
| | G255 | | | | | |
| | G0 | | | | | |

The response time is defined as the following figure and shall be measured by switching the input signal for "black" and "white".

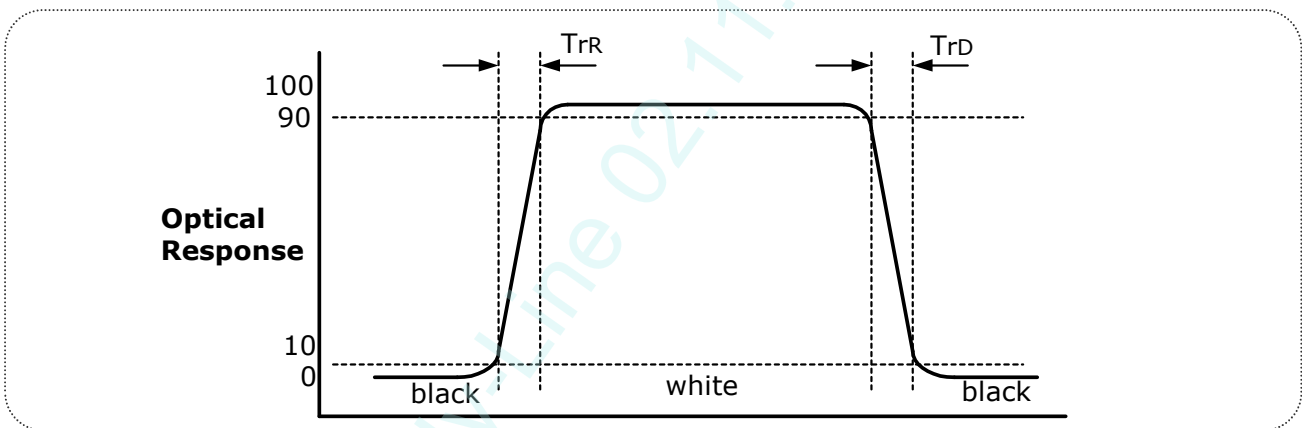

FIG.8 Response time

Product Specification

5. Color shift is the angle at which the average color difference for all Macbeth is lower than 0.02.

For more information see FIG.9 **(By EZ Contrast)**

- Color difference ($\Delta u'v'$)

$$u' = \frac{4x}{-2x+12y+3} \quad v' = \frac{9y}{-2x+12y+3} \quad \Delta u'v' = \sqrt{(u'_1 - u'_2)^2 + (v'_1 - v'_2)^2}$$

$$Avg (\Delta u'v') = \frac{\sum_{i=1}^{24} (\Delta u'v')_i}{24}$$

u'_1, v'_1 : $u'v'$ value at viewing angle direction
 u'_2, v'_2 : $u'v'$ value at front ($\theta=0$)
 i : Macbeth chart number (Define 23 page)

- Pattern size : 25% Box size
- Viewing angle direction of color shift : Horizontal, Vertical

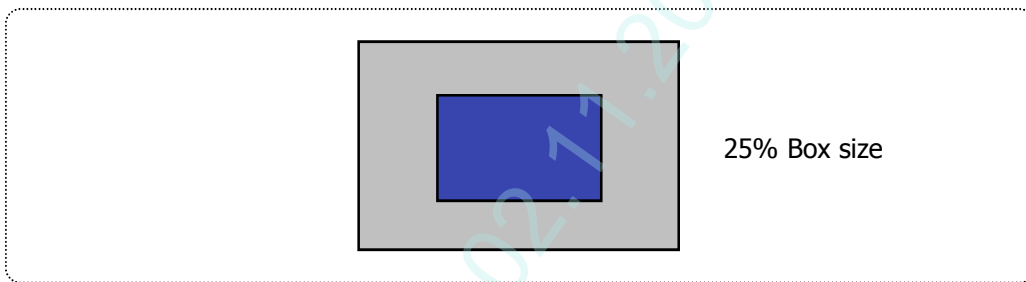

FIG.9 Color Shift Test Pattern

Average RGB values in Bruce RGB for Macbeth Chart

| | | | | | | |
|---|-----------|---------------|--------------|-----------|--------------|---------------|
| | Dark skin | Light skin | Blue sky | Foliage | Blue flower | Bluish green |
| R | 395 | 827 | 343 | 311 | 519 | 459 |
| G | 227 | 571 | 451 | 411 | 475 | 799 |
| B | 183 | 495 | 647 | 187 | 743 | 715 |
| | Orange | Purplish blue | Moderate red | Purple | Yellow green | Orange yellow |
| R | 879 | 227 | 847 | 307 | 643 | 923 |
| G | 419 | 279 | 271 | 159 | 775 | 651 |
| B | 99 | 699 | 351 | 347 | 235 | 119 |
| | Blue | Green | Red | Yellow | Magenta | cyan |
| R | 107 | 291 | 791 | 967 | 831 | 143 |
| G | 131 | 595 | 111 | 851 | 251 | 507 |
| B | 583 | 263 | 151 | 147 | 607 | 691 |
| | White | Neutral 8 | Neutral 6.5 | Neutral 5 | Neutral 3.5 | black |
| R | 963 | 827 | 623 | 443 | 255 | 91 |
| G | 963 | 827 | 623 | 443 | 255 | 91 |
| B | 963 | 827 | 623 | 443 | 255 | 91 |

Product Specification

6. Viewing angle is the angle at which the contrast ratio is greater than 10. The angles are determined for the horizontal or x axis and the vertical or y axis with respect to the z axis which is normal to the LCD surface. For more information see FIG.10 **(By PR880)**

Dimension of viewing angle range.

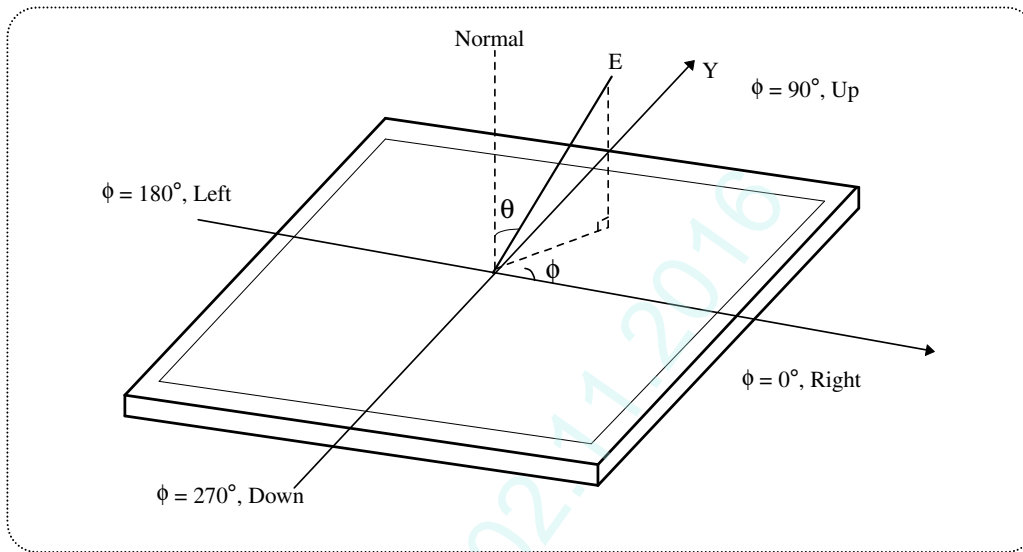

FIG.10 Viewing angle

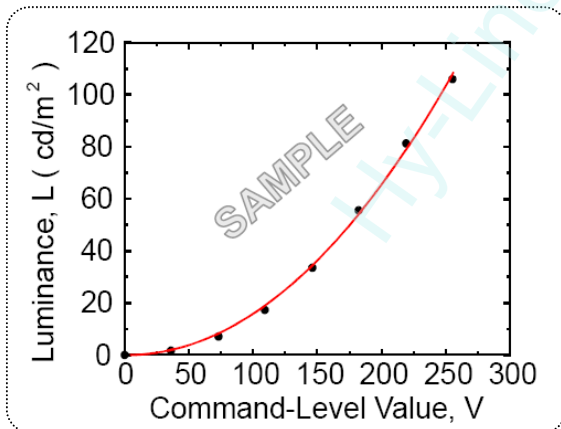

FIG.11 Sample Luminance vs. gray scale (using a 256 bit gray scale)

$$L = aV^r + L_b$$

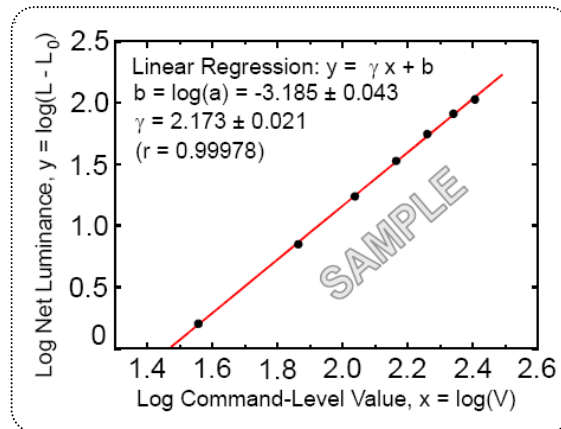

FIG.12 Sample Log-log plot of luminance vs. gray scale

$$\log(L - L_b) = r \log(V) + \log(a)$$

Here the Parameter a and γ relate the signal level V to the luminance L.
The GAMMA we calculate from the log-log representation (FIG.10)

Product Specification

7. Gamma Value is approximately 2.2. For more information see Table 10.

Table 10. Gray Scale Specification

| Gray Level | Relative Luminance [%] (Typ.) |
|------------|-------------------------------|
| 0 | 0.10 |
| 63 | 0.30 |
| 127 | 1.08 |
| 191 | 2.50 |
| 255 | 4.71 |
| 319 | 7.70 |
| 383 | 11.52 |
| 447 | 16.18 |
| 511 | 21.72 |
| 575 | 28.15 |
| 639 | 35.51 |
| 703 | 43.81 |
| 767 | 53.07 |
| 831 | 63.30 |
| 895 | 74.52 |
| 959 | 86.75 |
| 1023 | 100 |

Product Specification

5. Mechanical Characteristics

The contents provide general mechanical characteristics. In addition the figures in the next page are detailed mechanical drawing of the LCD.

| | | |
|---------------------|---|-----------------|
| Outline Dimension | Horizontal | 536.3mm |
| | Vertical | 313.9mm |
| | Depth | 12.9 mm |
| Bezel Area | Horizontal | - |
| | Vertical | - |
| Active Display Area | Horizontal | 525.66mm |
| | Vertical | 295.70mm |
| Weight | 1610g (Typ.) 1690g (Max.) | |
| Surface Treatment | Advanced Anti-glare treatment of the front polarizer (3H) | |

Notes : Please refer to a mechanic drawing in terms of tolerance at the next page.

Hy-Line 02-17-2016

Product Specification

<FRONT VIEW>

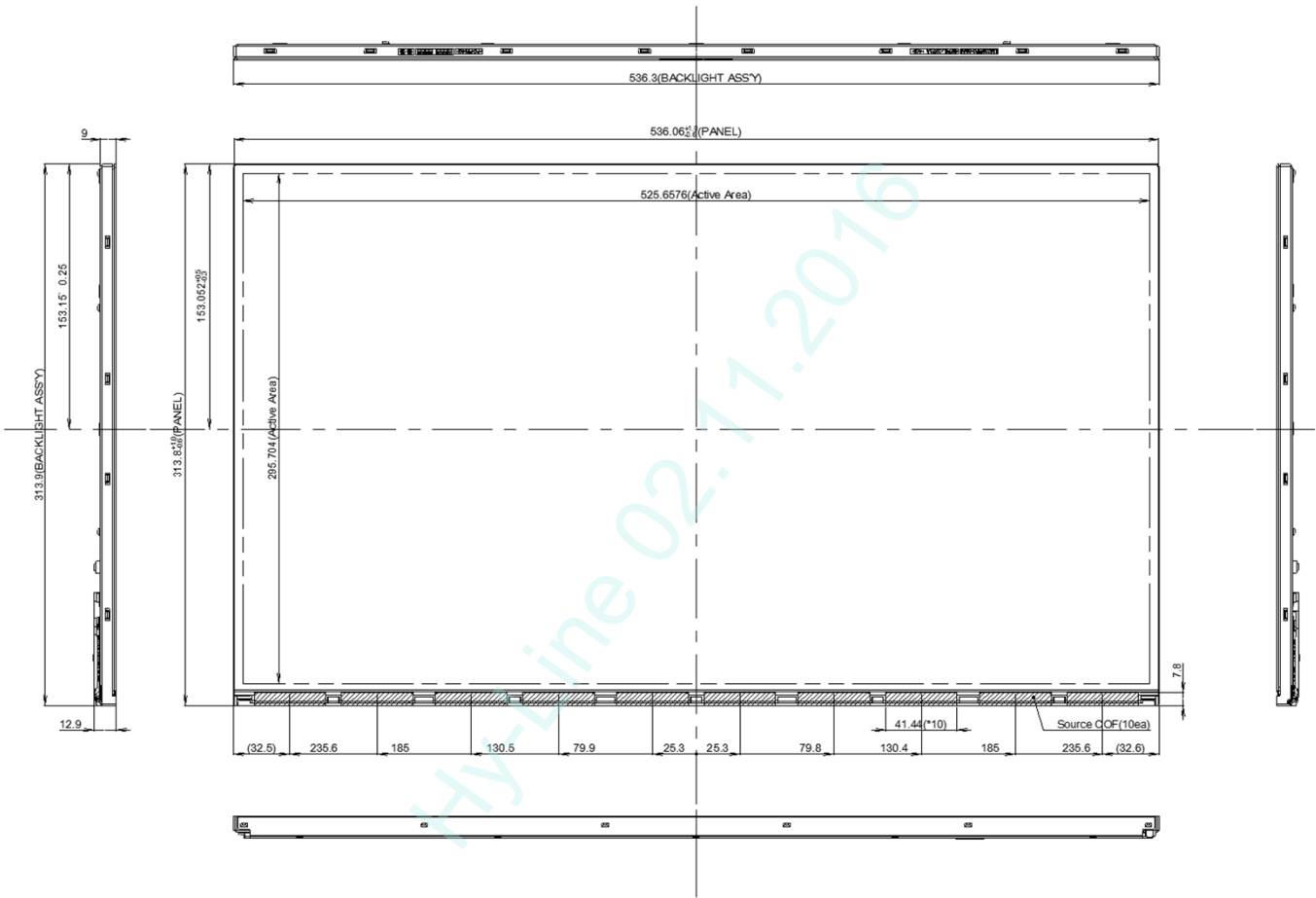

Product Specification

<REAR VIEW>

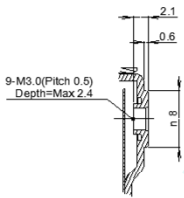
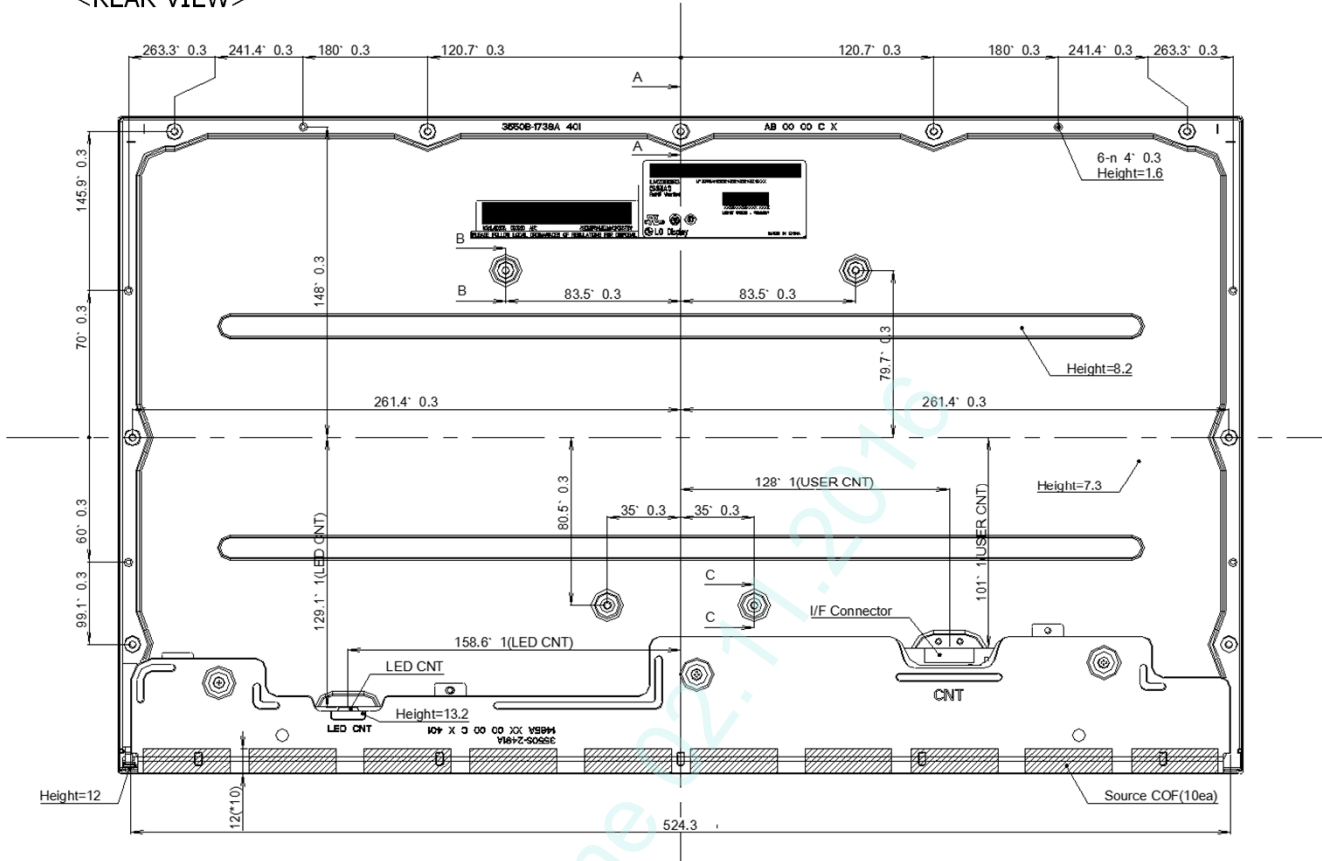

SECTION A-A
SCALE 2/1

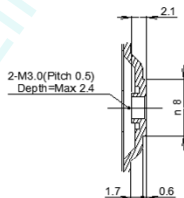

SECTION B-B
SCALE 2/1

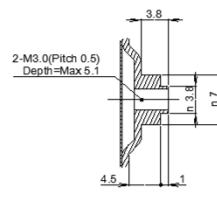

SECTION C-C
SCALE 2/1

Notes

1. I/F connector specification : GT05Q-30S-H10-MN(LSMtron) or Equivalent.
2. LED connector specification : SMO8B-SHJH(HF)(Manufactured by JST) or Equivalent.
3. Torque of user hole: 3.0~4.0(kgf-cm).
4. Tilt and partial disposition tolerance of display area as following
 - (1) Y-direction : $-0.45 < A < 0.45$, $-0.45 < B < 0.45$
 - (2) X-direction : $-0.45 < C < 0.45$, $-0.45 < D < 0.45$

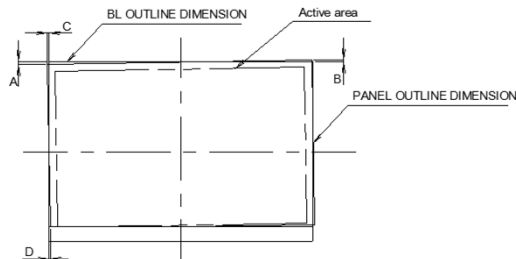

5. Unspecified tolerances to be ± 0.5
6. The LCM warp(warpage) is less than 1.0 on the surface plate
7. The COF area is weak & sensitive, so please don't press the COF area

Product Specification
6. Reliability

Environment test condition

| No | Test Item | Condition | Notes |
|----|--|---|-------|
| 1 | High temperature storage test | Ta= 60°C 240h | 1 |
| 2 | Low temperature storage test | Ta= -20°C 240h | 1 |
| 3 | High temperature operation test | Ta= 50°C 50%RH 240h | 1 |
| 4 | Low temperature operation test | Ta= 0°C 240h | 1 |
| 5 | Humidity condition Operation | Ta= 40 °C ,90%RH | |
| 6 | Altitude operating storage / shipment | 0 – 16,400 feet(5,000m) 0 - 40,000 feet(12,192m) | |
| 7 | Maximum Storage Humidity for 4 corner light leakage Mura. | Max 70%RH , Ta=40°C | |

Note 1. Result Evaluation Criteria:

TFT-LCD panels test should take place after cooling enough at room temperature.

In the standard condition, there should be no particular problems that may affect the display function.

 ※. T_a= Ambient Temperature

7. International Standards

7-1. Safety

- a) UL 60950-1, Underwriters Laboratories Inc.
Information Technology Equipment - Safety - Part 1 : General Requirements.
- b) CAN/CSA-C22.2 No. 60950-1-07, Canadian Standards Association.
Information Technology Equipment - Safety - Part 1 : General Requirements.
- c) EN 60950-1, European Committee for Electrotechnical Standardization (CENELEC).
Information Technology Equipment - Safety - Part 1 : General Requirements.
- d) IEC 60950-1, The International Electrotechnical Commission (IEC).
Information Technology Equipment - Safety - Part 1 : General Requirements

7-2. Environment

- a) RoHS, Directive 2011/65/EU of the European Parliament and of the council of 8 June 2011

Product Specification

8. Packing

8-1. Designation of Lot Mark

a) Lot Mark

| | | | | | | | | | | | | |
|---|---|---|---|---|---|---|---|---|---|---|---|---|
| A | B | C | D | E | F | G | H | I | J | K | L | M |
|---|---|---|---|---|---|---|---|---|---|---|---|---|

A,B,C : SIZE(INCH)
E : MONTH

D : YEAR
F ~ M : SERIAL NO.

Note

1. YEAR

| | | | | | | | | | | |
|------|------|------|------|------|------|------|------|------|------|------|
| Year | 2011 | 2012 | 2013 | 2014 | 2015 | 2016 | 2017 | 2018 | 2019 | 2020 |
| Mark | A | B | C | D | E | F | G | H | J | K |

2. MONTH

| | | | | | | | | | | | | |
|-------|-----|-----|-----|-----|-----|-----|-----|-----|-----|-----|-----|-----|
| Month | Jan | Feb | Mar | Apr | May | Jun | Jul | Aug | Sep | Oct | Nov | Dec |
| Mark | 1 | 2 | 3 | 4 | 5 | 6 | 7 | 8 | 9 | A | B | C |

b) Location of Lot Mark

Serial No. is printed on the label. The label is attached to the backside of the LCD module.
This is subject to change without prior notice.

8-2. Packing Form

1) Package quantity in one box : 10 pcs

b) Box Size : 635mm X 370mm X 400mm

Product Specification**9. PRECAUTIONS**

Please pay attention to the followings when you use this TFT LCD module.

9-1. MOUNTING PRECAUTIONS

- (1) You must mount a module using holes arranged in four corners or four sides.
- (2) You should consider the mounting structure so that uneven force (ex. Twisted stress) is not applied to the module. And the case on which a module is mounted should have sufficient strength so that external force is not transmitted directly to the module.
- (3) Please attach the surface transparent protective plate to the surface in order to protect the polarizer. Transparent protective plate should have sufficient strength in order to resist external force.
- (4) You should adopt radiation structure to satisfy the temperature specification.
- (5) Acetic acid type and chlorine type materials for the cover case are not desirable because the former generates corrosive gas of attacking the polarizer at high temperature and the latter causes circuit break by electro-chemical reaction.
- (6) Do not touch, push or rub the exposed polarizers with glass, tweezers or anything harder than HB pencil lead. And please do not rub with dust clothes with chemical treatment. Do not touch the surface of polarizer for bare hand or greasy cloth. (Some cosmetics are detrimental to the polarizer.)
- (7) When the surface becomes dusty, please wipe gently with absorbent cotton or other soft materials like chamois soaks with petroleum benzene. Normal-hexane is recommended for cleaning the adhesives used to attach front / rear polarizers. Do not use acetone, toluene and alcohol because they cause chemical damage to the polarizer.
- (8) Wipe off saliva or water drops as soon as possible. Their long time contact with polarizer causes deformations and color fading.
- (9) Do not open the case because inside circuits do not have sufficient strength.
- (10) As The IPS panel is sensitive & slim, please recommend the metal frame of the system supports the panel by the double side-mount.

9-2. OPERATING PRECAUTIONS

- (1) The spike noise causes the mis-operation of circuits. It should be lower than following voltage :
 $V = \pm 200\text{mV}$ (Over and under shoot voltage)
- (2) Response time depends on the temperature. (In lower temperature, it becomes longer.)
- (3) Brightness depends on the temperature. (In Higher temperature, it becomes lower.)
And in lower temperature, response time (required time that brightness is stable after turned on) becomes longer.
- (4) Be careful for condensation at sudden temperature change. Condensation makes damage to polarizer or electrical contacted parts. And after fading condensation, smear or spot will occur.
- (5) When fixed patterns are displayed for a long time, remnant image is likely to occur.
- (6) Module has high frequency circuits. Sufficient suppression to the electromagnetic interference shall be done by system manufacturers. Grounding and shielding methods may be important to minimized the interference.
- (7) Please do not give any mechanical and/or acoustical impact to LCM. Otherwise, LCM can't be operated its full characteristics perfectly.
- (8) A screw which is fastened up the steels should be a machine screw.
(if not, it causes metallic foreign material and deal LCM a fatal blow)
- (9) Please do not set LCD on its edge.
- (10) When LCMs are used for public display defects such as Yogore, image sticking can not be guarantee.
- (11) LCMs cannot support "Interlaced Scan Method"
- (12) When this reverse model is used as a forward-type model (PCB on top side), LGD can not guarantee any defects of LCM.
- (13) Please conduct image sticking test after 2-hour aging with Rolling PTN and normal temperature (25~40°C)

9-3. ELECTROSTATIC DISCHARGE CONTROL

Since a module is composed of electronic circuits, it is not strong to electrostatic discharge. Make certain that treatment persons are connected to ground through wrist band etc. And don't touch interface pin directly.

9-4. PRECAUTIONS FOR STRONG LIGHT EXPOSURE

Strong light exposure causes degradation of polarizer and color filter.

9-5. STORAGE

When storing modules as spares for a long time, the following precautions are necessary.

- (1) Store them in a dark place. Do not expose the module to sunlight or fluorescent light. Keep the temperature between 5°C and 35°C at normal humidity.
- (2) The polarizer surface should not come in contact with any other object.
It is recommended that they be stored in the container in which they were shipped.

9-6. HANDLING PRECAUTIONS FOR PROTECTION FILM

- (1) The protection film is attached to the bezel with a small masking tape.
When the protection film is peeled off, static electricity is generated between the film and polarizer.
This should be peeled off slowly and carefully by people who are electrically grounded and with well ion-blown equipment or in such a condition, etc.
- (2) When the module with protection film attached is stored for a long time, sometimes there remains a very small amount of glue still on the bezel after the protection film is peeled off.
- (3) You can remove the glue easily. When the glue remains on the bezel surface or its vestige is recognized, please wipe them off with absorbent cotton waste or other soft material like chamois soaked with normal-hexane.