

## ***TFT-Display Datenblatt***

Modell LM238WR2-SLA1

### **Kurzdaten**

Hersteller	LG Display
Diagonale	23,8" / 58,4 cm
Format	wide
Auflösung	3840x2160
Backlight	LED / 300 cd/m <sup>2</sup>
Interface	LVDS
Touchscreen	nein
Temperatur	0...+50 °C (Betrieb)

Product Specification

# SPECIFICATION FOR APPROVAL

- (●) Preliminary Specification
- ( ) Final Specification

Title	23.8" UHD TFT LCD
-------	-------------------

BUYER	General
MODEL	

SUPPLIER	LG Display Co., Ltd.
*MODEL	LM238WR2
SUFFIX	SLA1

\*When you obtain standard approval,  
please use the above model name without suffix

APPROVED BY	SIGNATURE DATE
/	_____
/	_____
/	_____

Please return 1 copy for your confirmation with your signature and comments.

APPROVED BY	SIGNATURE DATE
C.K. Lee / G.Manager	_____
<b>REVIEWED BY</b>	
K.H. Hwang / Manager [C]	_____
S.Y. An / Manager [M]	_____
S.H. Han / Manager [O]	_____
T.H. Shin / Manager [P]	_____
<b>PREPARED BY</b>	
S.T. Kim / Engineer	_____

**Product Engineering Dept.  
LG Display Co., Ltd**

**Product Specification**
Contents

No	ITEM	Page
	COVER	1
	CONTENTS	2
	RECORD OF REVISIONS	3
1	GENERAL DESCRIPTION	4
2	ABSOLUTE MAXIMUM RATINGS	5
3	ELECTRICAL SPECIFICATIONS	6
3-1	ELECTRICAL CHARACTREISTICS	6
3-2	INTERFACE CONNECTIONS	9
3-3	LVDS CHARACTERISTICS	12
3-4	SIGNAL TIMING SPECIFICATIONS	15
3-5	SIGNAL TIMING WAVEFORMS	16
3-6	COLOR INPUT DATA REFERENCE	17
3-7	POWER SEQUENCE & DIP CONDITION FOR LCD MODULE	18
4	OPTICAL SPECIFICATIONS	20
5	MECHANICAL CHARACTERISTICS	25
6	RELIABILITY	28
7	INTERNATIONAL STANDARDS	29
7-1	SAFETY	29
7-2	EMC	29
7-3	ENVIRONMENT	29
8	PACKING	30
8-1	DESIGNATION OF LOT MARK	30
8-2	PACKING FORM	30
9	PRECAUTIONS	31



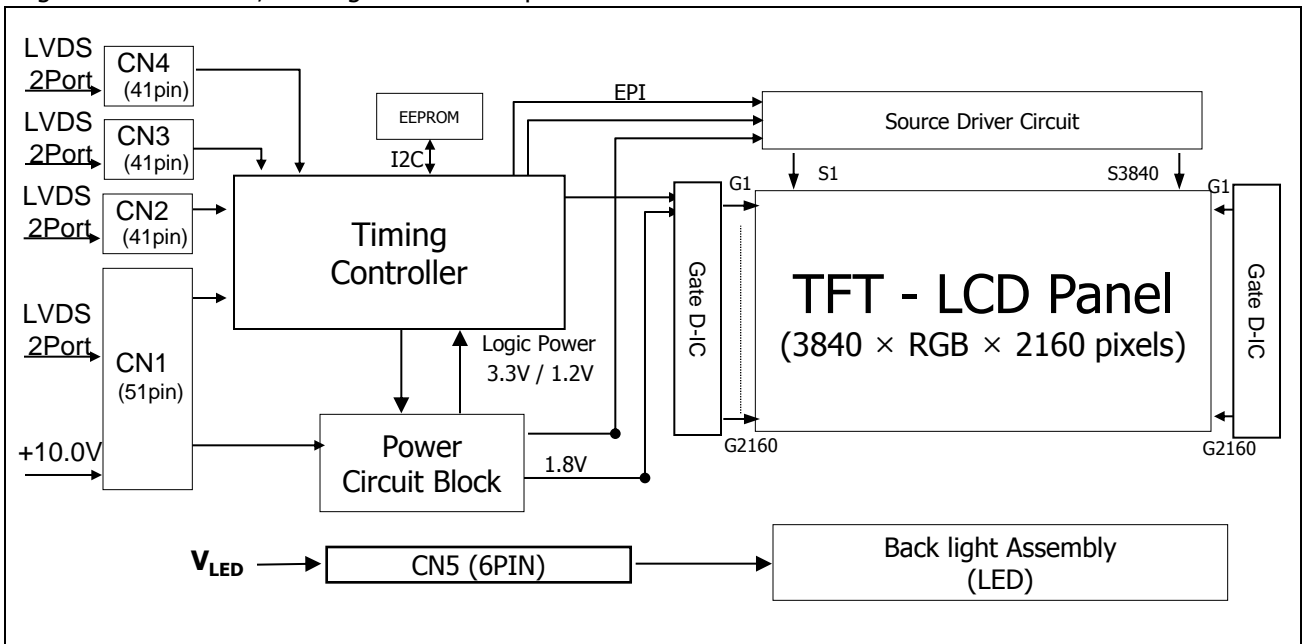
## Product Specification

### 1. General Description

LM238WR2 is a Color Active Matrix Liquid Crystal Display with a Light Emitting Diode (LED) backlight Assembly without LED driver. The matrix employs a-Si Thin Film Transistor as the active element. It is a transmissive type display operating in the normally black mode. It has a 23.8 inch diagonally measured active display area with UHD resolution (3840 horizontal by 2160 vertical pixel array) Each pixel is divided into Red, Green and Blue sub-pixels or dots which are arranged in vertical stripes. Gray scale or the brightness of the sub-pixel color is determined with a 10-bit gray scale signal for each dot, thus, presenting a palette of more than 1.07Billion colors with A-FRC (Advanced Frame Rate Control).

It has been designed to apply LVDS interface.

It is intended to support displays where high brightness, super wide viewing angle, high color saturation, and high color are important.



**[ FIG.1 ] Block diagram**

### General Features

Active Screen Size	23.8 inches(60.47cm) diagonal
Outline Dimension	545.0(H) x 323.4(V) x 14.4(D) mm (Typ.)
Pixel Pitch	0.13725 mm x 0.13725 mm
Pixel Format	3840 horiz. By 2160 vert. Pixels RGB stripes arrangement
Color Depth	1.07 Billion colors, 10Bit (8Bit + A-FRC)
Luminance, White	300 cd/m <sup>2</sup> ( Center 1 Point, Typ.)
Viewing Angle(CR>10)	View Angle Free (R/L 178(Typ.), U/D 178(Typ.))
Power Consumption	Total 31.1(TBD) Watt (Typ.) (7.7 Watt @V <sub>lcd</sub> 23.4 Watt @I <sub>s</sub> =120mA)
Weight	1910 g (Typ.), 2100 g (Max)
Display Operating Mode	Transmissive mode, normally black
Surface Treatment	Advanced Anti-glare treatment of the front polarizer (3H)

Product Specification

**2. Absolute Maximum Ratings**

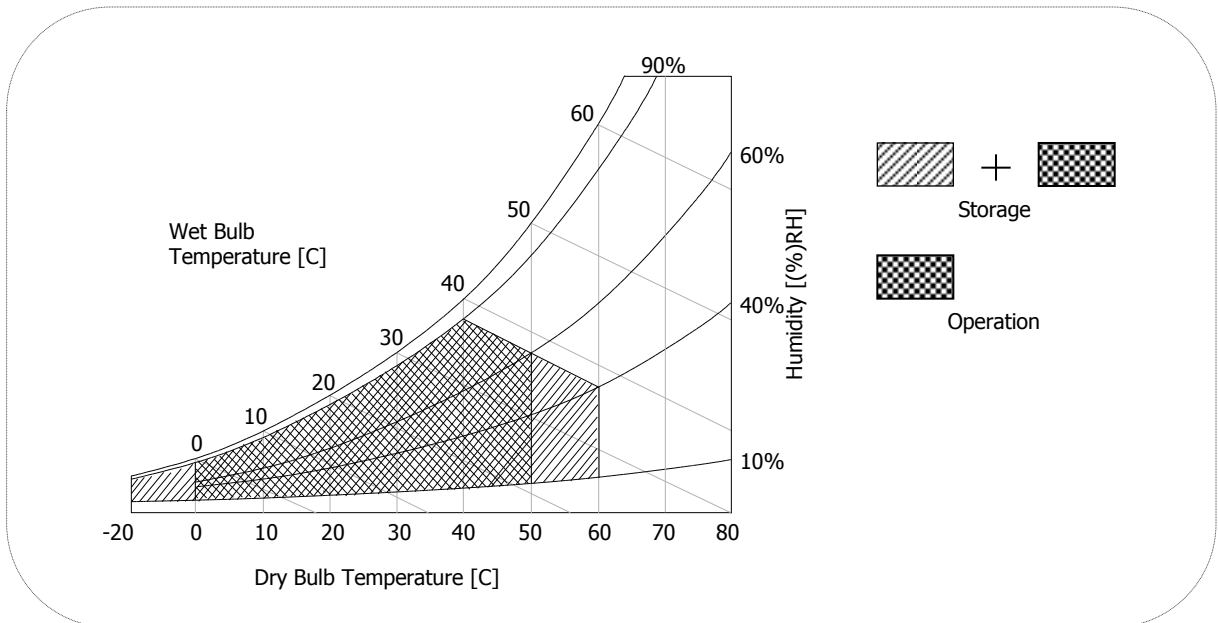
The following are maximum values which, if exceeded, may cause faulty operation or damage to the unit.

**Table 1. ABSOLUTE MAXIMUM RATINGS**

Parameter	Symbol	Values		Units	Notes
		Min	Max		
Power Input Voltage	V <sub>LCD</sub>	-0.3	12	V <sub>dc</sub>	at 25 ± 2°C
Operating Temperature	T <sub>OP</sub>	0	50	°C	1, 2, 3
Storage Temperature	T <sub>ST</sub>	-20	60	°C	
Operating Ambient Humidity	H <sub>OP</sub>	10	90	%RH	
Storage Humidity	H <sub>ST</sub>	10	90	%RH	

- Note : 1. Temperature and relative humidity range are shown in the figure below.  
 Wet bulb temperature should be 39 °C Max, and no condensation of water.  
 2. Maximum Storage Humidity is up to 40°C, 70% RH only for 4 corner light leakage Mura.  
 3. Storage condition is guaranteed under packing condition  
 4. LCM Surface Temperature should be Min. 0°C and Max. 65°C under the V<sub>LCD</sub>=10V, f<sub>V</sub>=60Hz, 25°C ambient Temp. no humidity control and LED string current is typical value.

**FIG.2 Temperature and relative humidity**



## Product Specification

### 3. Electrical Specifications

#### 3-1. Electrical Characteristics

It requires two power inputs. One is employed to power the LCD electronics and to drive the TFT array and liquid crystal. The second input power for the LED/Backlight, is typically generated by a LED Driver. The LED Driver is an external unit to the LCDs.

**Table 2-1. ELECTRICAL CHARACTERISTICS**

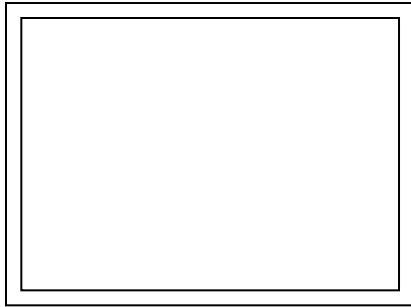
Parameter	Symbol	Values			Unit	Notes
		Min	Typ	Max		
MODULE :						
Power Supply Input Voltage	V <sub>LCD</sub>	9.5	10.0	10.5	Vdc	5
Permissive Power Input Ripple	V <sub>dRF</sub>			200	mV <sub>p-p</sub>	1
Power Supply Input Current	I <sub>LCD</sub>	-	(770)	(962)	mA	2
		-	(960)	(1200)	mA	3
Power Consumption	P <sub>c</sub> TYP	-	(7.7)	(9.62)	Watt	2
	P <sub>c</sub> MAX	-	(9.6)	(12)	Watt	3
Rush current	I <sub>RUSH</sub>	-		3	A	4

Note :

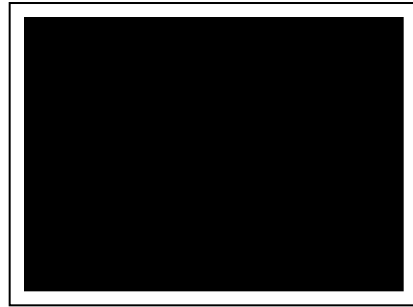
1. Permissive power ripple should be measured under V<sub>LCD</sub>=10.0V, 25 ± 2°C, f<sub>v</sub>=60Hz condition and at that time, we recommend the bandwidth configuration of oscilloscope is to be under 20Mhz.
2. The specified current and power consumption are under the V<sub>LCD</sub>=10.0V, 25 ± 2°C, f<sub>v</sub>=60Hz condition whereas mosaic pattern(8 x 6) is displayed and f<sub>v</sub> is the frame frequency.
3. The current is specified at the maximum current pattern.
4. The duration of rush current is about 2ms and rising time of power Input is 1ms(min.).
5. V<sub>LCD</sub> level must be measured at two points on LCM PCB - between V<sub>LCD</sub>(test point) and LCM Ground. The measured results need to meet the Power supply input voltage spec.  
(Test condition : maximum power pattern , 25 ± 2°C, f<sub>v</sub>=60Hz)

Product Specification

- **Permissive Power input ripple** ( $V_{LCD} = 10.0V$ ,  $25^{\circ}C$ ,  $f_v$  (frame frequency)=MAX condition)

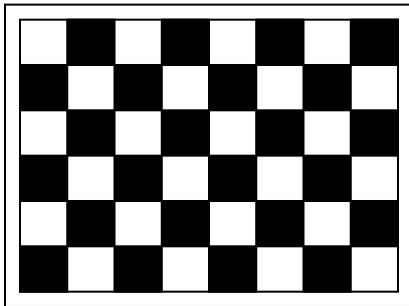


**White pattern**

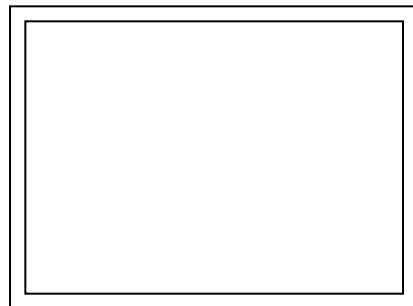


**Black pattern**

- **Power consumption** ( $V_{LCD} = 10V$ ,  $25^{\circ}C$ ,  $f_v$  (frame frequency)=60Hz condition)



**Typical power Pattern**



**Maximum power Pattern**

**FIG.3 Mosaic pattern & White Pattern for power consumption measurement**



**Product Specification**
**Table 2-2. ELECTRICAL CHARACTERISTICS of LED bar**

Parameter	Symbol	Values			Unit	Notes
		Min.	Typ.	Max.		
LED String Current	Is	-	120	125	mA	1, 2, 5
LED String Voltage	Vs	45.6	48.8	52.0	V	1, 5
Power Consumption	PBar	-	23.4	25.0	Watt	1, 2, 4
LED Life Time	LED_LT	30,000	-	-	Hrs	3

Notes) The LED Bar consists of 64 LED packages, 4 strings (parallel) x 16packages (serial)

**LED driver design guide**

- : The design of the LED driver must have specifications for the LED in LCD Assembly.  
 The performance of the LED in LCM, for example life time or brightness, is extremely influenced by the characteristics of the LED driver.  
 So all the parameters of an LED driver should be carefully designed and output current should be Constant current control.  
 Please control feedback current of each string individually to compensate the current variation among the strings of LEDs.  
 When you design or order the LED driver, please make sure unwanted lighting caused by the mismatch of the LED and the LED driver (no lighting, flicker, etc) never occurs.  
 When you confirm it, the LCD module should be operated in the same condition as installed in your instrument.

1. The specified values are for a single LED bar.
2. The specified current is defined as the input current for a single LED string with 100% duty cycle.
3. The LED life time is defined as the time when brightness of LED packages become 50% or less than the initial value under the conditions at  $T_a = 25 \pm 2^\circ\text{C}$  and LED string current is typical value.
4. The power consumption shown above does not include loss of external driver.  
 The typical power consumption is calculated as  $P_{\text{Bar}} = V_s(\text{Typ.}) \times I_s(\text{Typ.}) \times \text{No. of strings}$ .  
 The maximum power consumption is calculated as  $P_{\text{Bar}} = V_s(\text{Max.}) \times I_s(\text{Typ.}) \times \text{No. of strings}$ .
5. LED operating conditions are must not exceed Max. ratings.

## Product Specification

### 3-2. Interface Connections

#### 3-2-1. LCD Module

- LCD Connector(CN1) : IS050-C51B-C39-A(UJU) or FI-RE51S-HF(JAE) or compatible. Refer to below and next Page table.

- Mating Connector : FI-RE51HL(JAE) or compatible

**Table 3. MODULE CONNECTOR(CN1) PIN CONFIGURATION**

No	Symbol	Description	No	Symbol	Description
1	GND	Ground	27	NC	No Connection
2	NC	No Connection	28	R2AN	SECOND LVDS Receiver Signal (A-)
3	NC	No Connection	29	R2AP	SECOND LVDS Receiver Signal (A+)
4	SDA	SDA	30	R2BN	SECOND LVDS Receiver Signal (B-)
5	SCL	SCL	31	R2BP	SECOND LVDS Receiver Signal (B+)
6	NC	No Connection	32	R2CN	SECOND LVDS Receiver Signal (C-)
7	Mstar	Input mode selection L : Normal mode, H : Dual mode	33	R2CP	SECOND LVDS Receiver Signal (C+)
8	NC	No Connection (ITLC)	34	GND	Ground
9	NC	No Connection (PWM OUT)	35	R2CLKN	SECOND LVDS Receiver Clock Signal(-)
10	NC	No Connection	36	R2CLKP	SECOND LVDS Receiver Clock Signal(+)
11	GND	Ground	37	GND	Ground
12	R1AN	FIRST LVDS Receiver Signal (A-)	38	R2DN	SECOND LVDS Receiver Signal (D-)
13	R1AP	FIRST LVDS Receiver Signal (A+)	39	R2DP	SECOND LVDS Receiver Signal (D+)
14	R1BN	FIRST LVDS Receiver Signal (B-)	40	R2EN	SECOND LVDS Receiver Signal (E-)
15	R1BP	FIRST LVDS Receiver Signal (B+)	41	R2EP	SECOND LVDS Receiver Signal (E+)
16	R1CN	FIRST LVDS Receiver Signal (C-)	42	Reserved	No connection or GND
17	R1CP	FIRST LVDS Receiver Signal (C+)	43	Reserved	No connection or GND
18	GND	Ground	44	GND	Ground
19	R1CLKN	FIRST LVDS Receiver Clock Signal(-)	45	GND	Ground (RBF)
20	R1CLKP	FIRST LVDS Receiver Clock Signal(+)	46	GND	Ground
21	GND	Ground	47	NC	No connection
22	R1DN	FIRST LVDS Receiver Signal (D-)	48	VLCD	Power Supply +10.0V
23	R1DP	FIRST LVDS Receiver Signal (D+)	49	VLCD	Power Supply +10.0V
24	R1EN	FIRST LVDS Receiver Signal (E-)	50	VLCD	Power Supply +10.0V
25	R1EP	FIRST LVDS Receiver Signal (E+)	51	VLCD	Power Supply +10.0V
26	Reserved	No connection or GND	-	-	-

- Note: 1. All GND(ground) pins should be connected together and to Vss which should also be connected to the LCD's metal frame.
2. All VLCD (power input) pins should be connected together.
3. ITLC is Interlace mode selection pin. (L : Normal Mode, H : Interlace Mode)  
 If you don't use this pin, it should be connected to GND  
 (Low Level Input Voltage : GND ~ 0.4V, High Level Input Voltage : 1.6 ~ 3.6V)

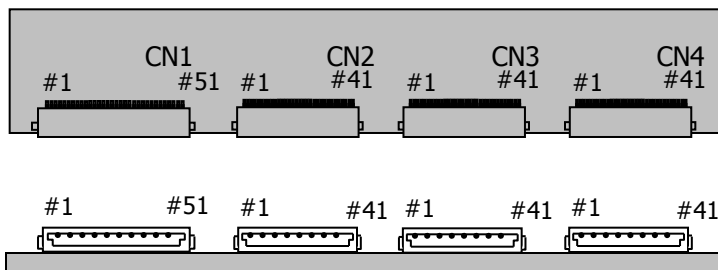
Product Specification

- LCD Connector(CN2,3,4): IS050-C41B-C39-A(UJU) or FI-RE41S-HF(JAE) or compatible. Refer to below table.
- Mating Connector : FI-RE41HL(JAE) or compatible.

**Table 4. MODULE CONNECTOR(CN2,3,4) PIN CONFIGURATION**

No	Symbol	Description	No	Symbol	Description
1	NC	No connection (Reserved)	22	R3EN	THIRD LVDS Receiver Signal (E-)
2	NC	No connection	23	R3EP	THIRD LVDS Receiver Signal (E+)
3	NC	No connection	24	GND	Ground
4	NC	No connection	25	GND	Ground
5	NC	No connection	26	R4AN	FORTH LVDS Receiver Signal (A-)
6	NC	No connection	27	R4AP	FORTH LVDS Receiver Signal (A+)
7	NC	No connection	28	R4BN	FORTH LVDS Receiver Signal (B-)
8	NC	No connection	29	R4BP	FORTH LVDS Receiver Signal (B+)
9	GND	Ground	30	R4CN	FORTH LVDS Receiver Signal (C-)
10	R3AN	THIRD LVDS Receiver Signal (A-)	31	R4CP	FORTH LVDS Receiver Signal (C+)
11	R3AP	THIRD LVDS Receiver Signal (A+)	32	GND	Ground
12	R3BN	THIRD LVDS Receiver Signal (B-)	33	R4CLKN	FORTH LVDS Receiver Clock Signal(-)
13	R3BP	THIRD LVDS Receiver Signal (B+)	34	R4CLKP	FORTH LVDS Receiver Clock Signal(+)
14	R3CN	THIRD LVDS Receiver Signal (C-)	35	GND	Ground
15	R3CP	THIRD LVDS Receiver Signal (C+)	36	R4DN	FORTH LVDS Receiver Signal (D-)
16	GND	Ground	37	R4DP	FORTH LVDS Receiver Signal (D+)
17	R3CLKN	THIRD LVDS Receiver Clock Signal(-)	38	R4EN	FORTH LVDS Receiver Signal (E-)
18	R3CLKP	THIRD LVDS Receiver Clock Signal(+)	39	R4EP	FORTH LVDS Receiver Signal (E+)
19	GND	Ground	40	GND	Ground
20	R3DN	THIRD LVDS Receiver Signal (D-)	41	GND	Ground
21	R3DP	THIRD LVDS Receiver Signal (D+)	-		

- Notes : 1. All GND(ground) pins should be connected together to the LCD module's metal frame.  
2. LVDS pin (pin No. #22,23,38,39) are used for 10Bit(D) of the LCD module.



**FIG.4 Rear view of LCM**

- [CN1]  
-Part/No. : IS050-C51B-C39-A(UJU)  
FI-RE51S-HF(JAE)  
- Mating connector : FI-RE51HL  
(Manufactured by JAE)  
[CN2,3,4]  
-Part/No. : IS050-C41B-C39-A(UJU)  
FI-RE41S-HF(JAE)  
- Mating connector : FI-RE41HL  
(Manufactured by JAE)

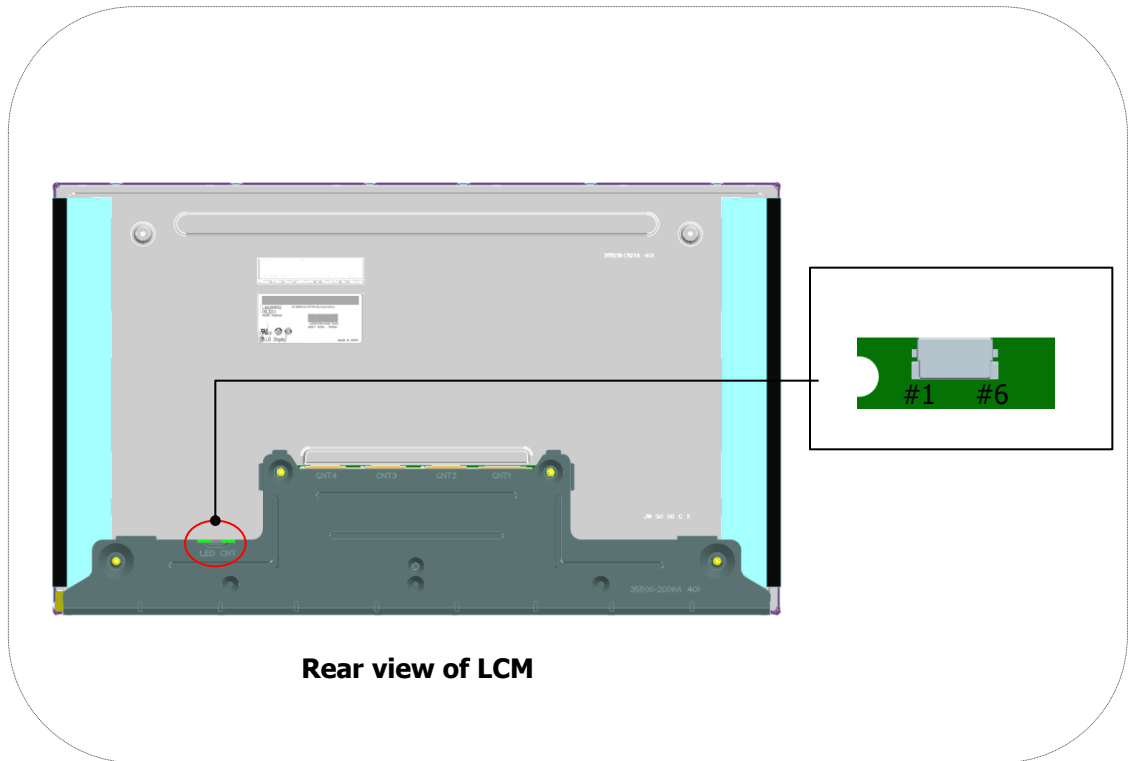
Product Specification

**3-2-2. BACKLIGHT CONNECTOR PIN CONFIGURATION(CN5)**

- Connector : SM06B-SHJH (HF) (Manufactured by JST) or Equivalent
- Mating Connector : SHJP-06V-S(HF) or SHJP-06V-A-K(HF) or Equivalent

**Table 5. LED CONNECTOR PIN CONFIGURATION**

Pin	Symbol	Description
1	FB1	Channel1 Current Feedback
2	FB2	Channel2 Current Feedback
3	VLED	LED Power Supply
4	VLED	LED Power Supply
5	FB3	Channel3 Current Feedback
6	FB4	Channel4 Current Feedback



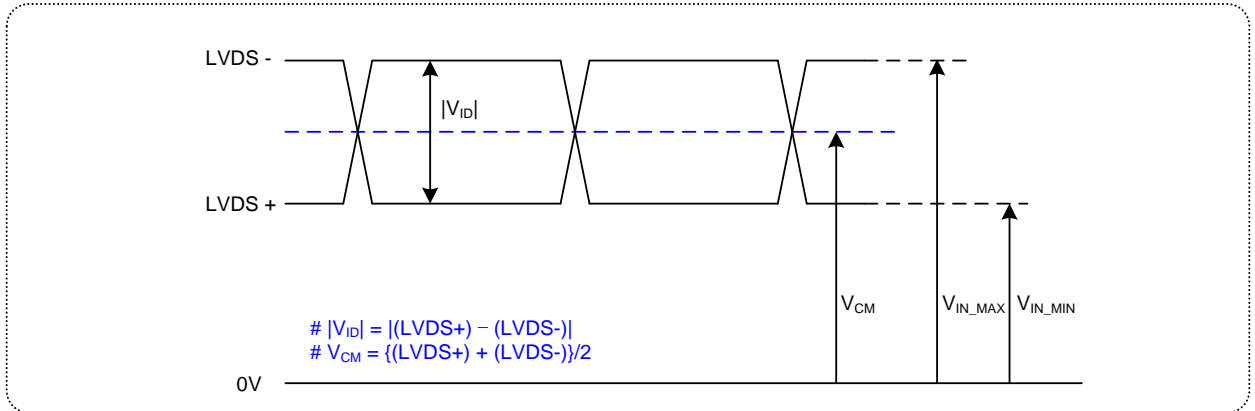
**Rear view of LCM**

**[ Figure 5 ] Backlight connector view**

Product Specification

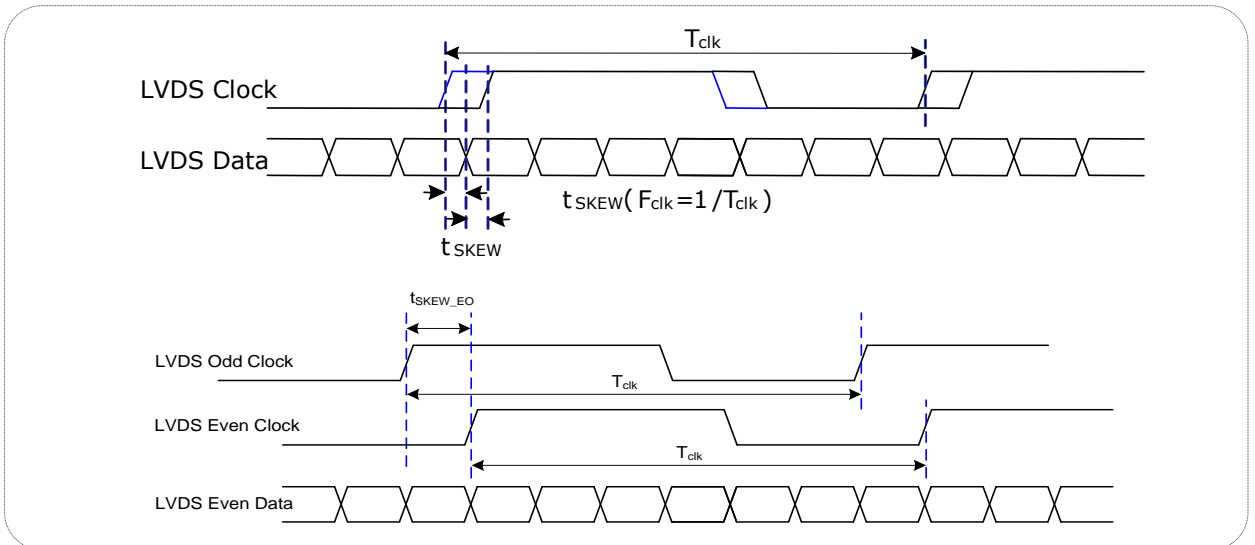
3-3. LVDS characteristics

3-3-1. DC Specification



Description	Symbol	Min	Max	Unit	Notes
LVDS Differential Voltage	V <sub>ID</sub>	200	600	mV	-
LVDS Common mode Voltage	V <sub>CM</sub>	1.0	1.5	V	-
LVDS Input Voltage Range	V <sub>IN</sub>	0.7	1.8	V	-
Change in common mode Voltage	ΔV <sub>CM</sub>	-	250	mV	-

3-3-2. AC Specification

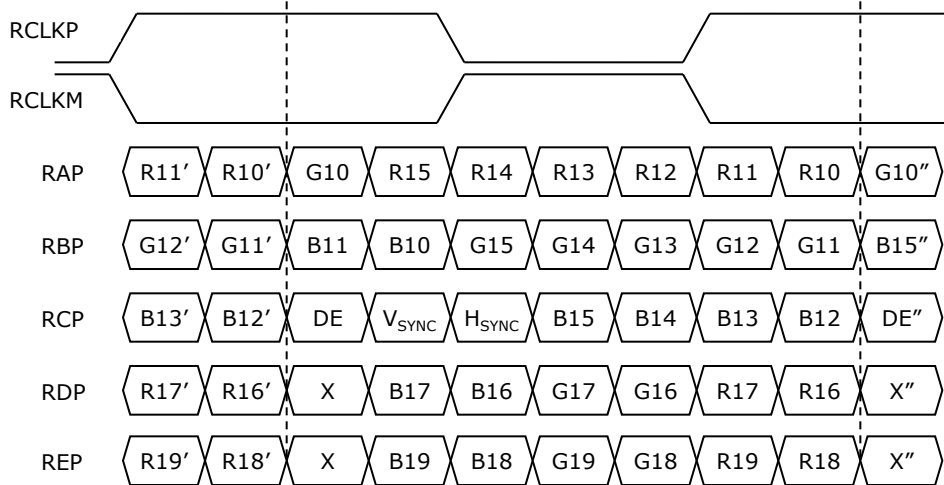


Description	Symbol	Min	Max	Unit	Notes
LVDS Clock to Data Skew Margin	t <sub>SKEW</sub>	-300	+300	ps	
LVDS Clock to Clock Skew Margin	t <sub>SKEW_EO</sub>	- 1/7	+ 1/7	T <sub>clk</sub>	-

Product Specification

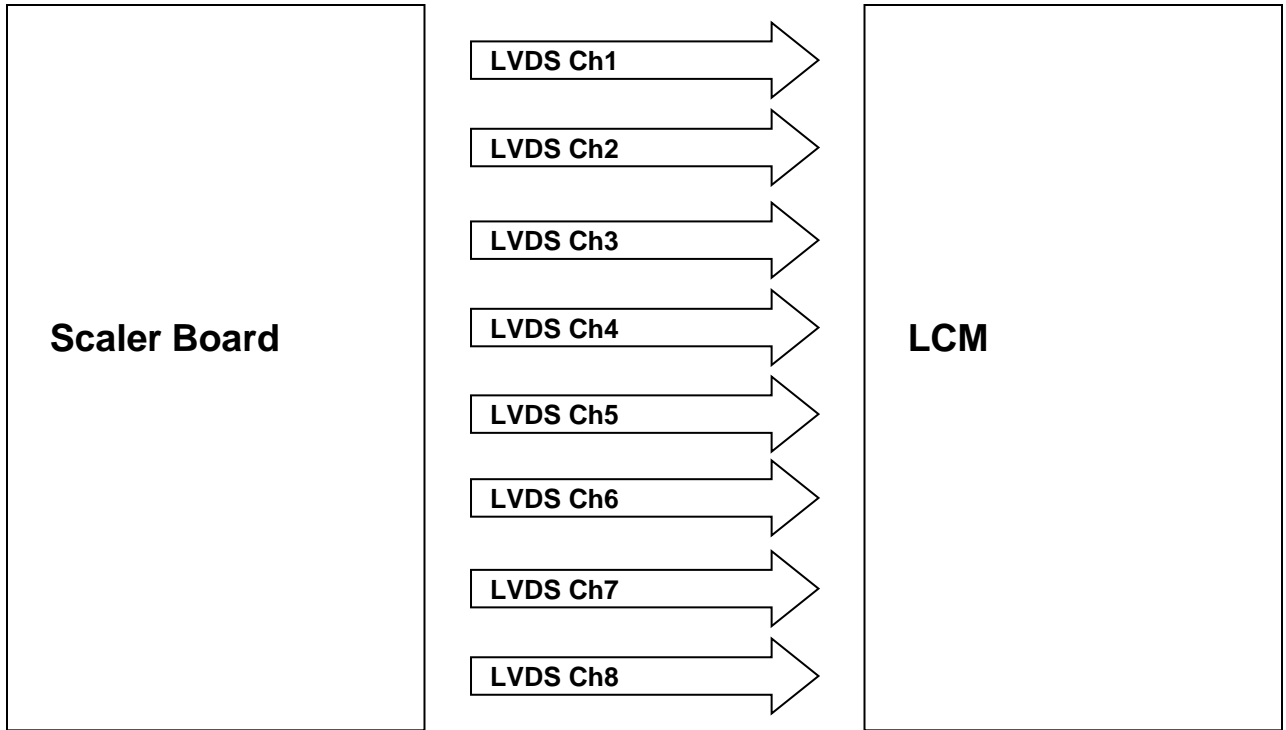
3-3-3. LVDS Data format

■ 10Bit Data-Mapping (VESA format)



Product Specification

3-3-4. LVDS description



■ Normal ( Single Screen, Pin # 7 of CN1 = Low )

- LVDS Ch1 : 1 → 9 → ... 1913 → 1921 → 1929 → ... 3825 → 3833
- LVDS Ch2 : 2 → 10 → ... 1914 → 1922 → 1930 → ... 3826 → 3834
- LVDS Ch3 : 3 → 11 → ... 1915 → 1923 → 1931 → ... 3827 → 3835
- LVDS Ch4 : 4 → 12 → ... 1916 → 1924 → 1932 → ... 3828 → 3836
- LVDS Ch5 : 5 → 13 → ... 1917 → 1925 → 1933 → ... 3829 → 3837
- LVDS Ch6 : 6 → 14 → ... 1918 → 1926 → 1934 → ... 3830 → 3838
- LVDS Ch7 : 7 → 15 → ... 1919 → 1927 → 1935 → ... 3831 → 3839
- LVDS Ch8 : 8 → 16 → ... 1920 → 1928 → 1936 → ... 3832 → 3840

■ Dual ( Dual Screen, Pin # 7 of CN1 = High )

- |  |                             |               |
|--|-----------------------------|---------------|
| LVDS Ch1 : 1 → 5 → 9 → 13 → ...            | → 1905 → 1909 → 1913 → 1917 | } Left image  |
| LVDS Ch2 : 2 → 6 → 10 → 14 → ...           | → 1906 → 1910 → 1914 → 1918 |               |
| LVDS Ch3 : 3 → 7 → 11 → 15 → ...           | → 1907 → 1911 → 1915 → 1919 |               |
| LVDS Ch4 : 4 → 8 → 12 → 16 → ...           | → 1908 → 1912 → 1916 → 1920 |               |
| LVDS Ch5 : 1921 → 1925 → 1929 → 1933 → ... | → 3825 → 3829 → 3833 → 3837 | } Right image |
| LVDS Ch6 : 1922 → 1926 → 1930 → 1934 → ... | → 3826 → 3830 → 3834 → 3838 |               |
| LVDS Ch7 : 1923 → 1927 → 1931 → 1935 → ... | → 3827 → 3831 → 3835 → 3839 |               |
| LVDS Ch8 : 1924 → 1928 → 1932 → 1936 → ... | → 3828 → 3832 → 3836 → 3840 |               |

**Product Specification**
**3-4. Signal Timing Specifications**

This is signal timing required at the input of the TMDS transmitter. All of the interface signal timing should be satisfied with the following specifications for its proper operation.

**Table 6. TIMING TABLE**

ITEM	Symbol		Min	Typ	Max	Unit	Note
DCLK	Period	tCLK	13.95	13.65	13.50	ns	Pixel frequency : Typ.585.98MHz
	Frequency	-	71.69	73.25	74.09	MHz	
Hsync	Period	tHP	556	560	564	tCLK	
	Horizontal Valid	tHV	480	480	480	tCLK	
	Horizontal Blank	tHB	76	80	84		
	Frequency	fH	121.87	129.60	130.03	KHz	
	Width	tWH	32	32	32	tCLK	
	Horizontal Back Porch	tHBP	30	32	34		
	Horizontal Front Porch	tHFP	14	16	18		
Vsync	Period	tVP	2178	2180	2182	tHP	
	Vertical Valid	tVV	2160	2160	2160	tHP	
	Vertical Blank	tVB	18	20	22	tHP	
	Frequency	fV	59.2	60	60.2	Hz	
	Width	tWV	4	4	4	tHP	
	Vertical Back Porch	tVBP	7	8	9		
	Vertical Front Porch	tVFP	7	8	9		

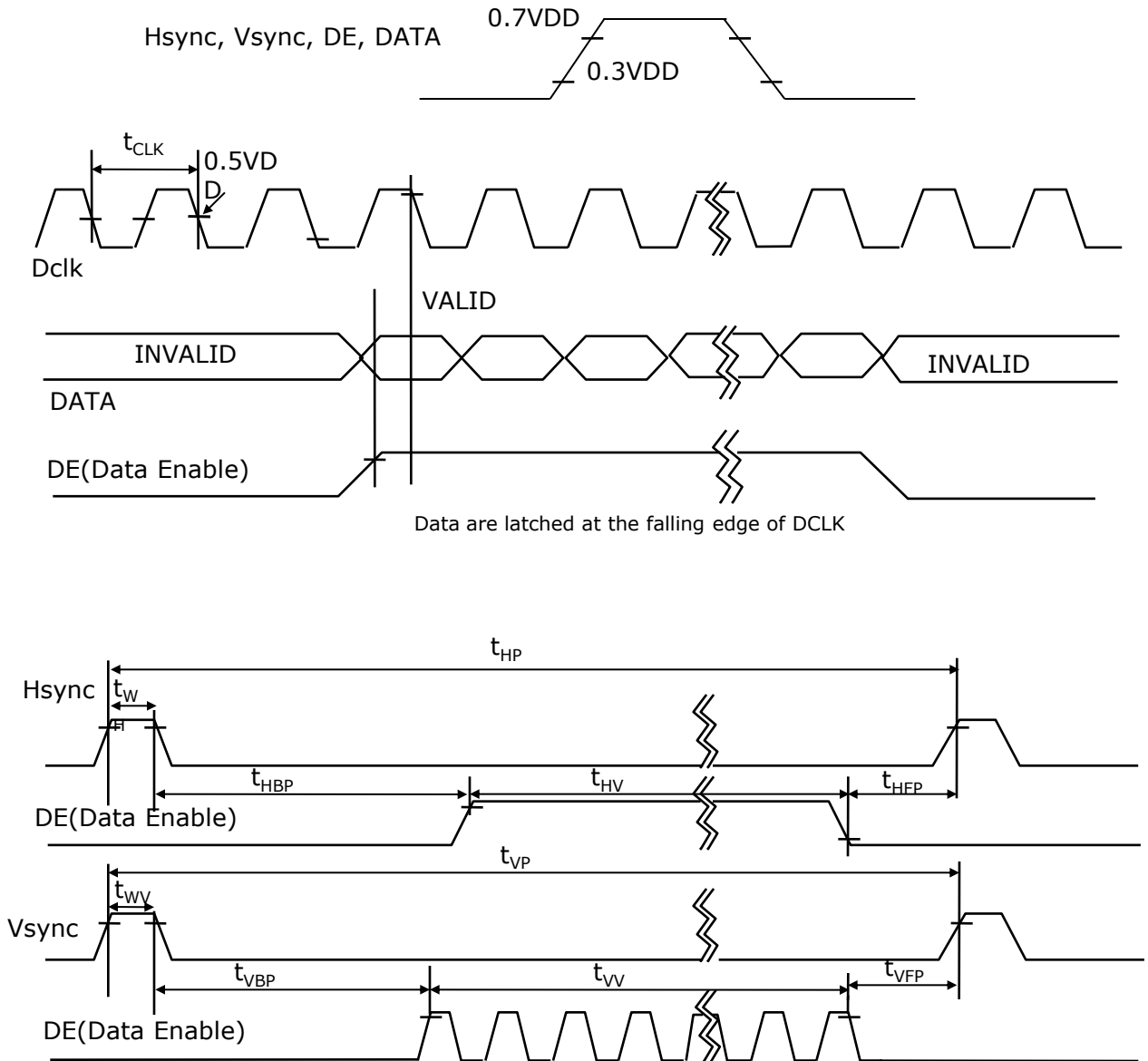
Note:

1. DE Only mode operation. The input of Hsync & Vsync signal does not have an effect on LCD normal operation.
2. The performance of the electro-optical characteristics may be influenced by variance of the vertical refresh rates.
3. Horizontal period should be even.



Product Specification

3-5. Signal Timing Waveforms



## Product Specification

### 3-6. Color Input Data Reference

The Brightness of each primary color(red,green,blue) is based on the 10-bit gray scale data input for the color; the higher the binary input, the brighter the color. The table below provides a reference for color versus data input.

**Table 7. COLOR DATA REFERENCE**

Color		Input Color Data																													
		RED										GREEN										BLUE									
		MSB					LSB					MSB					LSB					MSB				LSB					
		R9	R8	R7	R6	R5	R4	R3	R2	R1	R0	G9	G8	G7	G6	G5	G4	G3	G2	G1	G0	B9	B8	B7	B6	B5	B4	B3	B2	B1	B0
Basic Color	Black	0	0	0	0	0	0	0	0	0	0	0	0	0	0	0	0	0	0	0	0	0	0	0	0	0	0	0	0	0	0
	Red (1023)	1	1	1	1	1	1	1	1	1	1	0	0	0	0	0	0	0	0	0	0	0	0	0	0	0	0	0	0	0	0
	Green (1023)	0	0	0	0	0	0	0	0	0	0	1	1	1	1	1	1	1	1	1	1	0	0	0	0	0	0	0	0	0	0
	Blue (1023)	0	0	0	0	0	0	0	0	0	0	0	0	0	0	0	0	0	0	0	0	1	1	1	1	1	1	1	1	1	1
	Cyan	0	0	0	0	0	0	0	0	0	0	1	1	1	1	1	1	1	1	1	1	1	1	1	1	1	1	1	1	1	1
	Magenta	1	1	1	1	1	1	1	1	1	1	0	0	0	0	0	0	0	0	0	0	1	1	1	1	1	1	1	1	1	1
	Yellow	1	1	1	1	1	1	1	1	1	1	1	1	1	1	1	1	1	1	1	1	0	0	0	0	0	0	0	0	0	0
	White	1	1	1	1	1	1	1	1	1	1	1	1	1	1	1	1	1	1	1	1	1	1	1	1	1	1	1	1	1	1
RED	RED (000)	0	0	0	0	0	0	0	0	0	0	0	0	0	0	0	0	0	0	0	0	0	0	0	0	0	0	0	0	0	
	RED (001)	0	0	0	0	0	0	0	0	0	0	0	0	0	0	0	0	0	0	0	0	0	0	0	0	0	0	0	0	0	
	...	...										...										...									
	RED (1022)	1	1	1	1	1	1	1	1	1	0	0	0	0	0	0	0	0	0	0	0	0	0	0	0	0	0	0	0	0	0
	RED (1023)	1	1	1	1	1	1	1	1	1	1	0	0	0	0	0	0	0	0	0	0	0	0	0	0	0	0	0	0	0	0
GREEN	GREEN (000)	0	0	0	0	0	0	0	0	0	0	0	0	0	0	0	0	0	0	0	0	0	0	0	0	0	0	0	0	0	
	GREEN (001)	0	0	0	0	0	0	0	0	0	0	0	0	0	0	0	0	0	0	0	0	0	0	0	0	0	0	0	0	0	
	...	...										...										...									
	GREEN (1022)	0	0	0	0	0	0	0	0	0	0	1	1	1	1	1	1	1	1	1	0	0	0	0	0	0	0	0	0	0	0
	GREEN (1023)	0	0	0	0	0	0	0	0	0	0	1	1	1	1	1	1	1	1	1	1	0	0	0	0	0	0	0	0	0	0
BLUE	BLUE (000)	0	0	0	0	0	0	0	0	0	0	0	0	0	0	0	0	0	0	0	0	0	0	0	0	0	0	0	0	0	
	BLUE (001)	0	0	0	0	0	0	0	0	0	0	0	0	0	0	0	0	0	0	0	0	0	0	0	0	0	0	0	0	1	
	...	...										...										...									
	BLUE (1022)	0	0	0	0	0	0	0	0	0	0	0	0	0	0	0	0	0	0	0	0	1	1	1	1	1	1	1	1	1	0
	BLUE (1023)	0	0	0	0	0	0	0	0	0	0	0	0	0	0	0	0	0	0	0	0	1	1	1	1	1	1	1	1	1	1

Product Specification

3-7. Power Sequence & Dip condition for LCD Module

3-7-1. Power Sequence

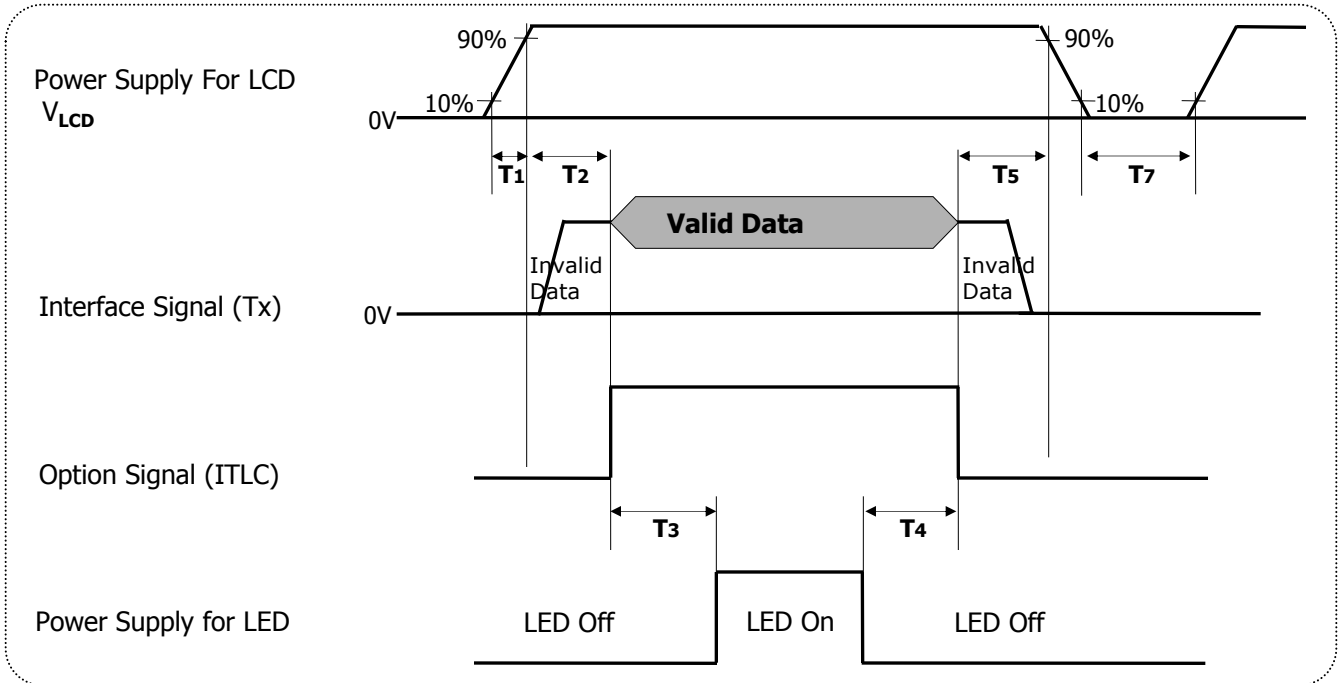


Table 8. POWER SEQUENCE

Parameter	Values			Units
	Min	Typ	Max	
T1	0.5	-	10	ms
T2	0.5	-	50	ms
T3	500	-	-	ms
T4	200	-	-	ms
T5	0.01	-	50	ms
T7	1000	-	-	ms

Notes : 1. Recommend to follow Power sequence at these case

-AC/DC Power On/Off

-Mode change ( Resolution, frequency, timing, sleep mode, Color depth change, etc. )

If not to follow power sequence, there is a risk of abnormal display. 1. Please avoid floating state of interface signal at invalid period.

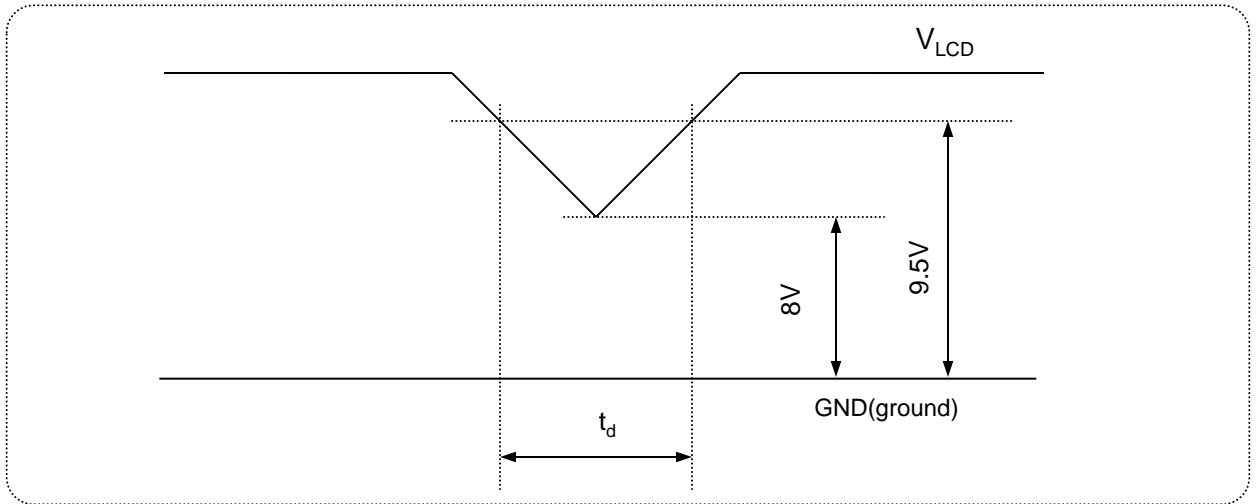
2. When the interface signal is invalid, be sure to pull down the power supply for LCD  $V_{LCD}$  to 0V.

3. The invalid signal means out of the signal timing specification which define as page 14.

4. The above power sequence should be satisfied the basic power on/off and resolution, timing transition.

5. LED power must be turn on after power supply for LCD and interface signal are valid.

3-7-2. VLCD Power Dip Condition



**FIG.5 Power dip condition**

1) Dip condition

$$8V \leq V_{LCD} < 9.5V, t_d \leq 20ms$$

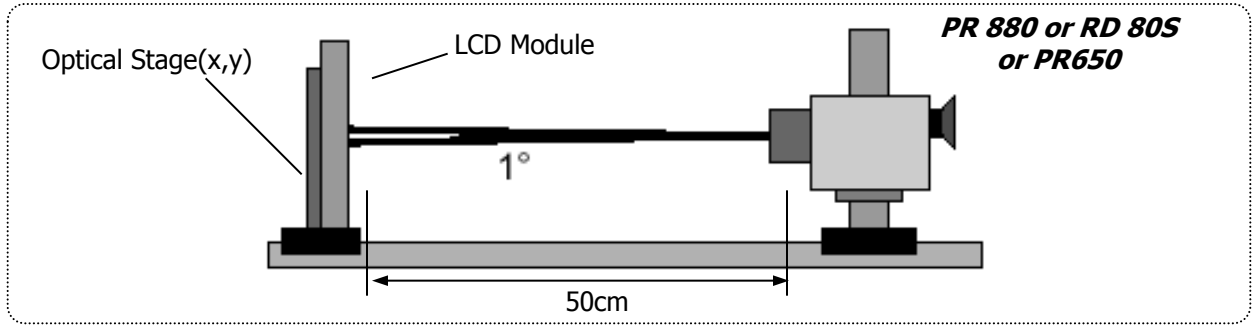
2)  $V_{LCD} < 8V$

$V_{LCD}$ -dip conditions should also follow the Power On/Off conditions for supply voltage.

**Product Specification**
**4. Optical Specifications**

Optical characteristics are determined after the unit has been 'ON' for approximately 30 minutes in a dark environment at  $25 \pm 2^\circ\text{C}$ . The values specified are at an approximate distance 50cm from the LCD surface at a viewing angle of  $\Phi$  and  $\theta$  equal to  $0^\circ$  and aperture 1 degree.

FIG. 6 presents additional information concerning the measurement equipment and method.


**FIG.6 Optical Characteristic Measurement Equipment and Method**
**Table 9. OPTICAL CHARACTERISTICS** ( $T_a=25^\circ\text{C}$ ,  $V_{\text{LCD}}=10\text{V}$ ,  $f_v=60\text{Hz}$  Dclk= 585.98MHz)  $I_s=120\text{mA}$ 

Parameter	Symbol	Values			Units	Notes	
		Min	Typ	Max			
Contrast Ratio	CR	600	1000	-		1	
Surface Luminance, white	$L_{\text{WH}}$	240	300	-	cd/m <sup>2</sup>	2	
Luminance Variation	$\delta_{\text{WHITE}}$	75	-	-	%	3	
Response Time	Rise Time	$T_{\text{rR}}$	-	7	12	ms	4
	Decay Time	$T_{\text{rD}}$	-	7	12	ms	4
	Gray To Gray	$T_{\text{GTG\_AVR}}$	-	14	25	ms	5
Color Coordinates [CIE1931] <b>(By PR650)</b>	RED	$R_x$	Typ -0.03	0.659	Typ +0.03		
		$R_y$		0.334			
	GREEN	$G_x$		0.301			
		$G_y$		0.639			
	BLUE	$B_x$		0.149			
		$B_y$		0.043			
	WHITE	$W_x$		0.313			
	$W_y$	0.329					
Color Shift	Horizontal	$\theta_{\text{CST\_H}}$	-	178	-	Degree	6
	Vertical	$\theta_{\text{CST\_V}}$	-	178	-		
Viewing Angle (CR>10)							
General	Horizontal	$\theta_{\text{H}}$	170	178	-	Degree	7
	Vertical	$\theta_{\text{V}}$	170	178	-		
Gray Scale		-		2.2			8

Product Specification

Notes 1. Contrast Ratio(CR) is defined mathematically as : **(By PR880)**

$$\text{Contrast Ratio} = \frac{\text{Surface Luminance with all white pixels}}{\text{Surface Luminance with all black pixels}}$$

It is measured at center point(Location P1)

- Surface luminance(L<sub>WH</sub>) is luminance value at Center 1 point(P1) across the LCD surface 50cm from the surface with all pixels displaying white. For more information see FIG.7 (By PR880)
- The variation in surface luminance, δ WHITE is defined as : **(By PR880)**

$$\delta_{WHITE} = \frac{\text{Minimum}(L_{P1}, L_{P2}, \dots, L_{P9})}{\text{Maximum}(L_{P1}, L_{P2}, \dots, L_{P9})} \times 100$$

Where L1 to L9 are the luminance with all pixels displaying white at 9 locations.  
For more information see FIG.7

- Response time is the time required for the display to transition from black to white (Rise Time, TrR) and from white to black (Decay Time, TrD). For additional information see FIG 8. **(By RD-80S)**
- Gray to gray response time is the time required for the display to transition from gray to gray. For additional information see Table 10. **(By PR880)**
- Color shift is the angle at which the average color difference for all Macbeth is lower than 0.02. For more information see FIG.9 **(By EZ Contrast)**

- Color difference ( $\Delta u'v'$ )

$$v' = \frac{9y}{-2x+12y+3}$$

$$\Delta u'v' = \sqrt{(u'_1 - u'_2)^2 + (v'_1 - v'_2)^2}$$

$$\text{Avg}(\Delta u'v') = \frac{\sum_{i=1}^{24} (\Delta u'v')_i}{24}$$

u'1, v'1 : u'v' value at viewing angle direction  
u'2, v'2 : u'v' value at front (θ=0)  
i : Macbeth chart number (Define 23 page)

- Pattern size : 25% Box size
- Viewing angle direction of color shift : Horizontal, Vertical

- Viewing angle is the angle at which the contrast ratio is greater than 10. The angles are determined for the horizontal or x axis and the vertical or y axis with respect to the z axis which is normal to the LCD surface. For more information see FIG.10 **(By PR880)**
- Gamma Value is approximately 2.2. For more information see Table 11.

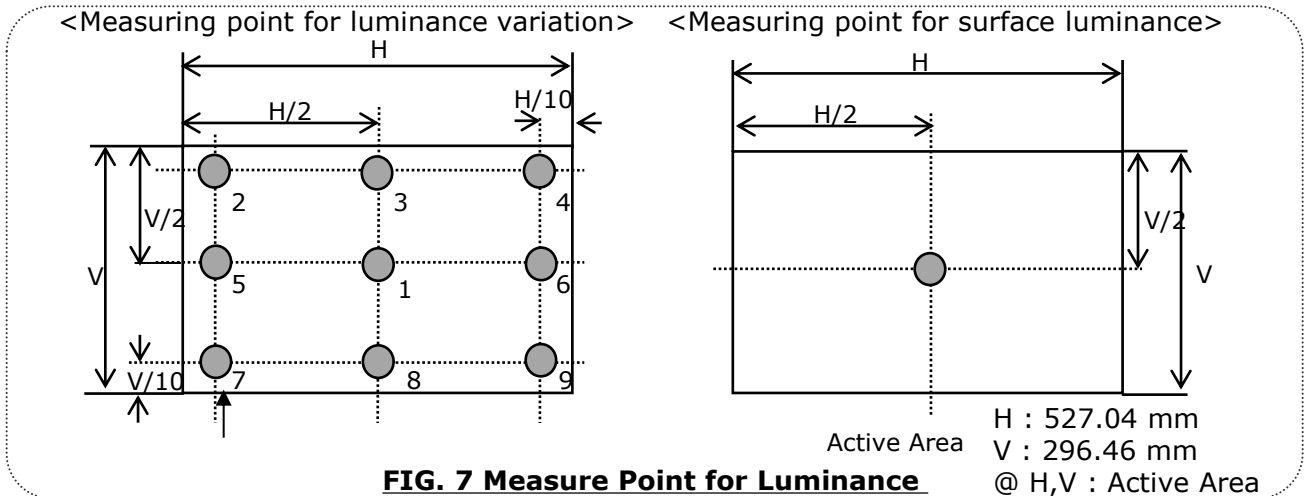
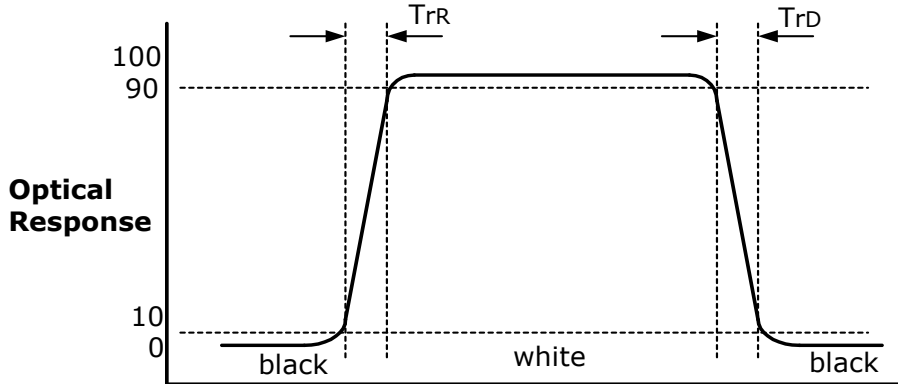


FIG. 7 Measure Point for Luminance

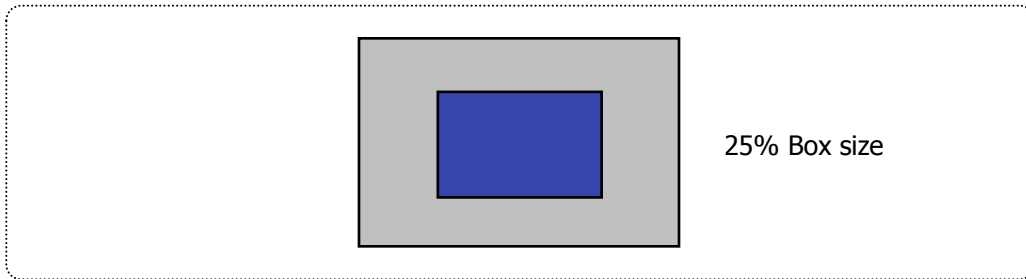
**Product Specification**

The response time is defined as the following figure and shall be measured by switching the input signal for "black" and "white".



**FIG.8 Response time**

Color shift is defined as the following test pattern and color.



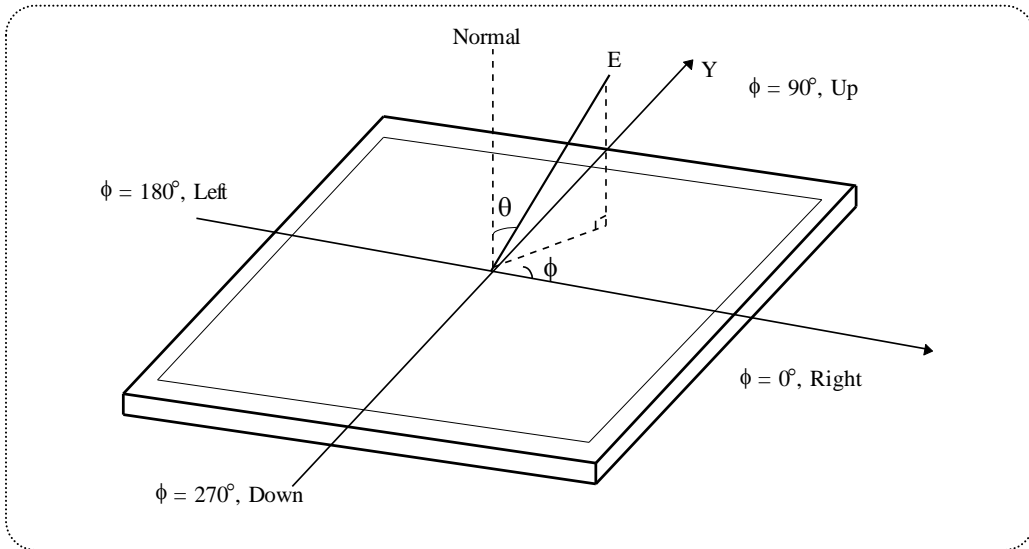
**FIG.9 Color Shift Test Pattern**

Average RGB values in Bruce RGB for Macbeth Chart

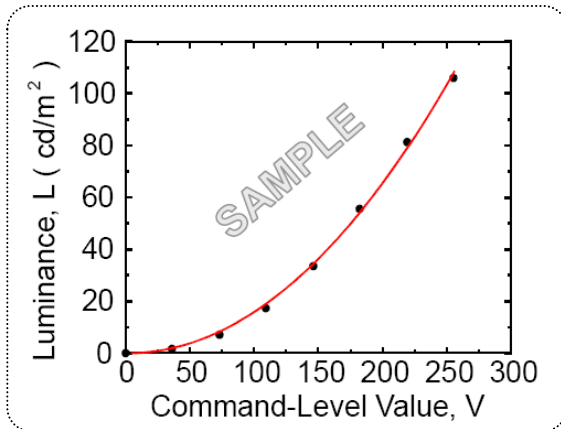
	Dark skin	Light skin	Blue sky	Foliage	Blue flower	Bluish green
R	395	827	343	311	519	459
G	227	571	451	411	475	799
B	183	495	647	187	743	715
	Orange	Purplish blue	Moderate red	Purple	Yellow green	Orange yellow
R	879	227	847	307	643	923
G	419	279	271	159	775	651
B	99	699	351	347	235	119
	Blue	Green	Red	Yellow	Magenta	cyan
R	107	291	791	967	831	143
G	131	595	111	851	251	507
B	583	263	151	147	607	691
	White	Neutral 8	Neutral 6.5	Neutral 5	Neutral 3.5	black
R	963	827	623	443	255	91
G	963	827	623	443	255	91
B	963	827	623	443	255	91

Product Specification

Dimension of viewing angle range.

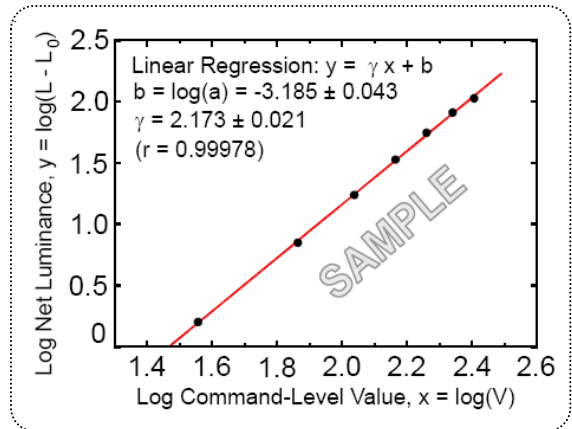


**FIG.10 Viewing angle**



**FIG.11 Sample Luminance vs. gray scale (using a 256 bit gray scale)**

$$L = aV^r + L_b$$



**FIG.12 Sample Log-log plot of luminance vs. gray scale**

$$\log(L - L_b) = r \log(V) + \log(a)$$

Here the Parameter  $a$  and  $\gamma$  relate the signal level  $V$  to the luminance  $L$ .  
The GAMMA we calculate from the log-log representation (FIG.11)



**Product Specification**
**Table 10. Gray to gray response time table**

Gray to Gray		Rising Time				
		G255	G191	G127	G63	G0
Falling Time	G255					
	G191					
	G127					
	G63					
	G0					

**Table 11. Gray Scale Specification**

Gray Level	Relative Luminance [%] (Typ.)
0	0.10
63	0.30
127	1.08
191	2.50
255	4.71
319	7.70
383	11.52
447	16.18
511	21.72
575	28.15
639	35.51
703	43.81
767	53.07
831	63.30
895	74.52
959	86.75
1023	100

**Product Specification**
**5. Mechanical Characteristics**

The contents provide general mechanical characteristics. In addition the figures in the next page are detailed mechanical drawing of the LCD.

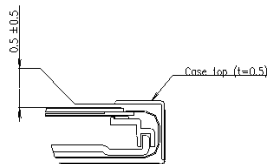
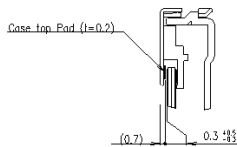
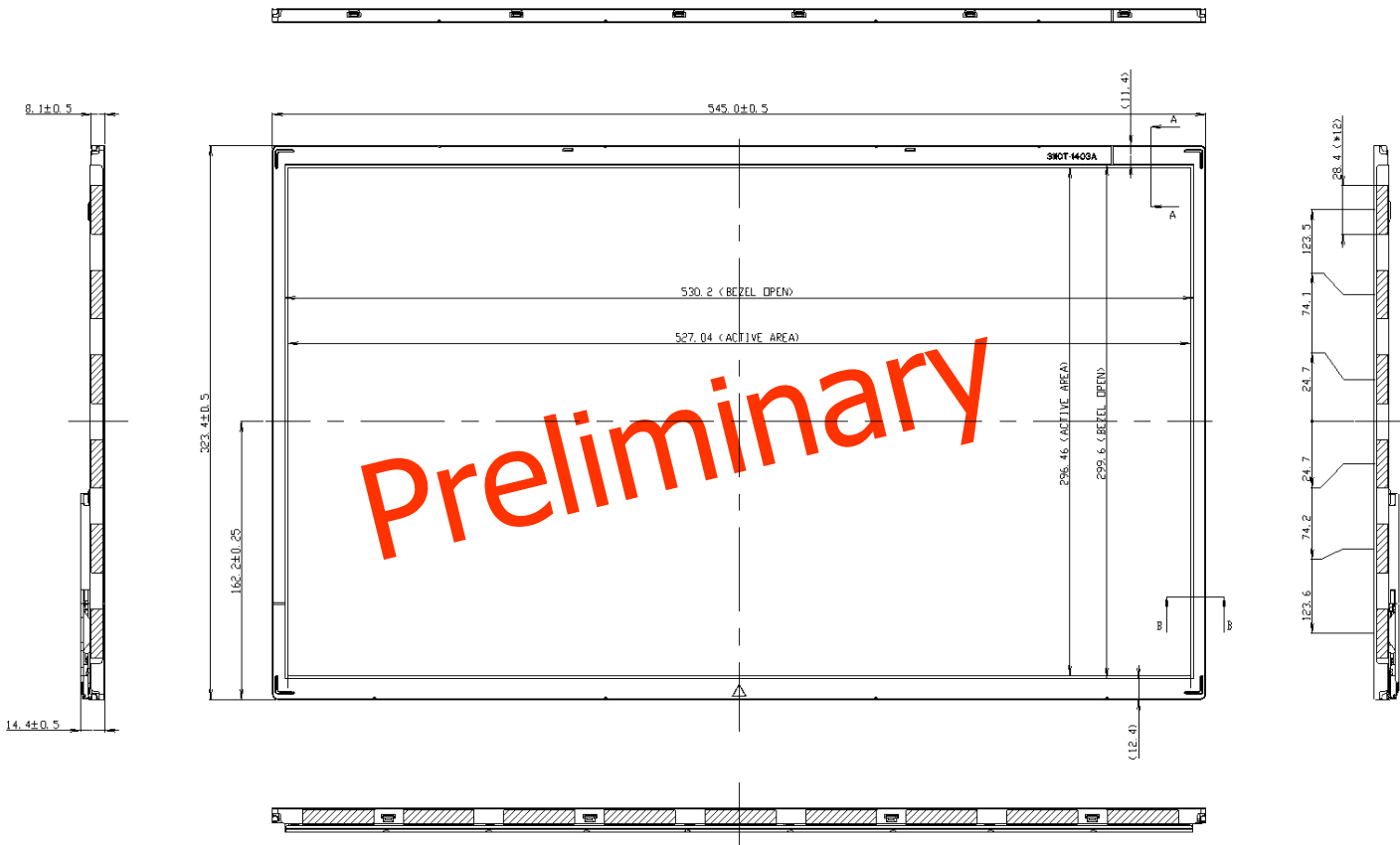
Outline Dimension	Horizontal	<b>545.0mm</b>
	Vertical	<b>323.4mm</b>
	Depth	<b>14.4 mm</b>
Bezel Area	Horizontal	<b>530.2mm</b>
	Vertical	<b>299.6mm</b>
Active Display Area	Horizontal	<b>527.04mm</b>
	Vertical	<b>296.46mm</b>
Weight	<b>1910g (Typ.) 2100g (Max.)</b>	
Surface Treatment	Advanced Anti-glare treatment of the front polarizer (3H)	

Notes : Please refer to a mechanic drawing in terms of tolerance at the next page.

Product Specification

<FRONT VIEW>

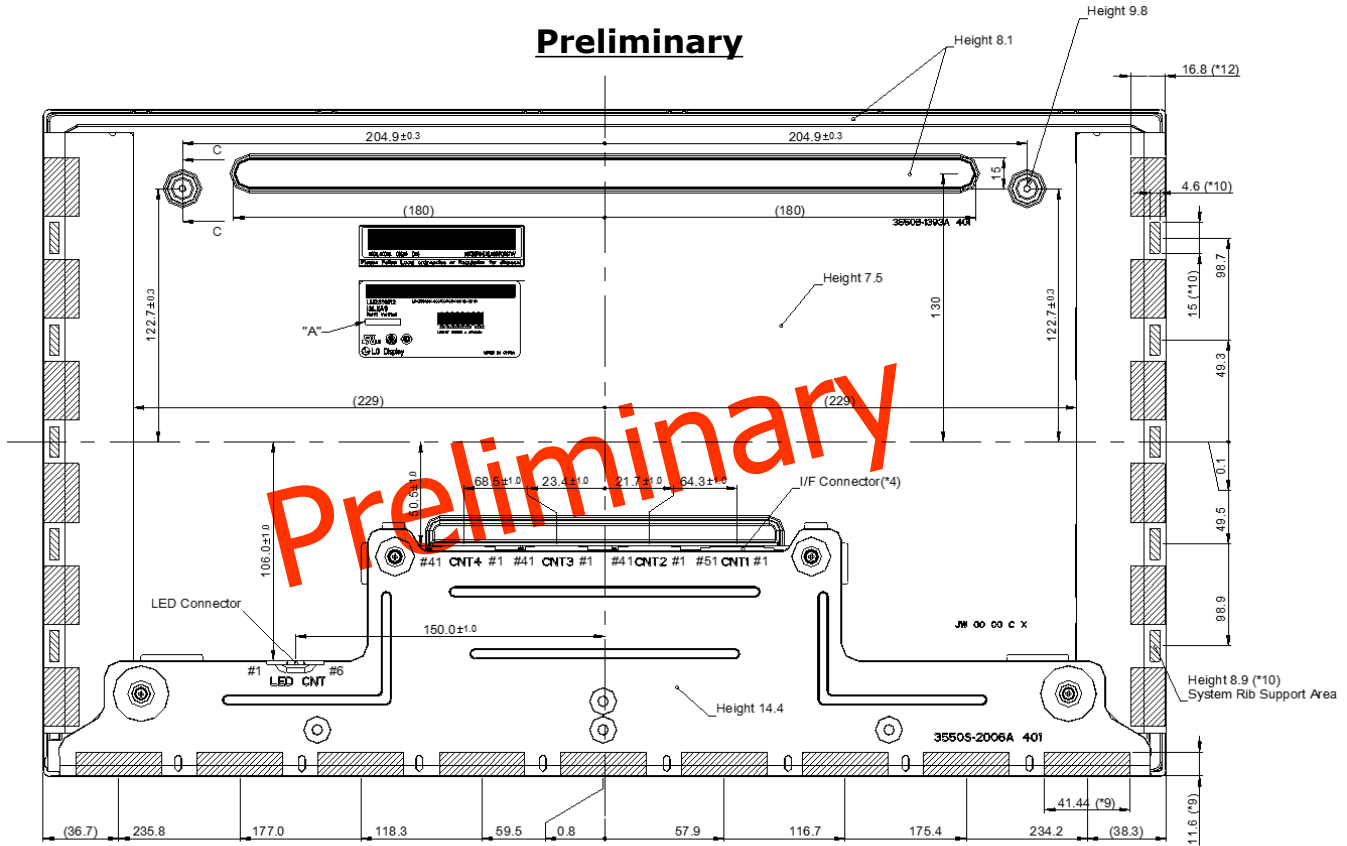
**Preliminary**



**Product Specification**

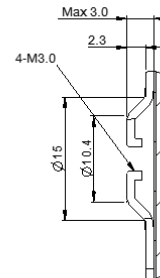
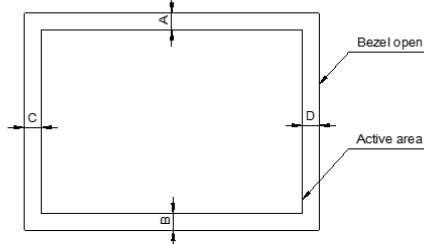
<REAR VIEW>

**Preliminary**



**Notes**

1. Unspecified tolerances are to be  $\pm 0.5$
2. Tilt and partial disposition tolerance of display area are as following.
  - (1) Y-direction : |A-B|  $\leq 1.4$
  - (2) X-direction : |C-D|  $\leq 1.4$



3. Torque of User Hole(Mount) : 3.0 ~4.0kgf.cm
4. LVDS input connector Specification
  - CN1 : IS050-C51B-C39-A(UJU) or FI-RE51S-HF(JAE)
  - CNT2,3,4 : IS050-C41B-C39-A(UJU) or FI-RE41S-HF(JAE)
5. LED Connector Specification : SM06B-SHJH (HF) (Manufactured by JST) or Equivalent
6. The COF area is weak & sensitive, so please don't press the COF area
7. The "A" phrase as following

SECTION C-C  
SCALE 2/1

Production Line	Description
eMPS Line	None
LGDGZ Line	Factory ID : LGDGZ

**Product Specification**
**6. Reliability**

Environment test condition

No	Test Item	Condition	Notes
1	High temperature storage test	Ta= 60°C 240h	1
2	Low temperature storage test	Ta= -20°C 240h	1
3	High temperature operation test	Ta= 50°C 50%RH 240h	1
4	Low temperature operation test	Ta= 0°C 240h	1
5	Vibration test (non-operating)	Wave form : random Vibration level : 1.0G RMS Bandwidth : 10-300Hz Duration : X,Y,Z, 10 min One time each direction	
6	Shock test (non-operating)	Shock level : 100Grms Waveform : half sine wave, 2ms Direction : ±X, ±Y, ±Z One time each direction	
7	Altitude Operating Storage / Shipment	0 - 16,500 feet(5,000m) 0 - 40,000 feet(12,192m)	

**Note 1. Result Evaluation Criteria:**

TFT-LCD panels test should take place after cooling enough at room temperature.

In the standard condition, there should be no particular problems that may affect the display function.

 ※. T<sub>a</sub>= Ambient Temperature

## **7. International Standards**

### **7-1. Safety**

- a) UL 60950-1, Underwriters Laboratories Inc.  
Information Technology Equipment - Safety - Part 1 : General Requirements.
- b) CAN/CSA C22.2 No.60950-1-07, Canadian Standards Association.  
Information Technology Equipment - Safety - Part 1 : General Requirements.
- c) EN 60950-1, European Committee for Electrotechnical Standardization (CENELEC).  
Information Technology Equipment - Safety - Part 1 : General Requirements.
- d) IEC 60950-1, The International Electrotechnical Commission (IEC).  
Information Technology Equipment - Safety - Part 1 : General Requirements.

### **7-2. Environment**

- a) RoHS, Directive 2011/65/EU of the European Parliament and of the council of 8 June 2011

Product Specification

## 8. Packing

### 8-1. Designation of Lot Mark

a) Lot Mark

A	B	C	D	E	F	G	H	I	J	K	L	M
---	---	---	---	---	---	---	---	---	---	---	---	---

A,B,C : SIZE(INCH)  
E : MONTH

D : YEAR  
F ~ M : SERIAL NO.

Note

1. YEAR

Year	2011	2012	2013	2014	2015	2016	2017	2018	2019	2020
Mark	A	B	C	D	E	F	G	H	J	K

2. MONTH

Month	Jan	Feb	Mar	Apr	May	Jun	Jul	Aug	Sep	Oct	Nov	Dec
Mark	1	2	3	4	5	6	7	8	9	A	B	C

b) Location of Lot Mark

Serial No. is printed on the label. The label is attached to the backside of the LCD module.  
This is subject to change without prior notice.

### 8-2. Packing Form

1) Package quantity in one box : 12ea

b) Box Size : 635\*370\*400mm

## Product Specification

### 9. PRECAUTIONS

Please pay attention to the followings when you use this TFT LCD module.

#### 9-1. MOUNTING PRECAUTIONS

- (1) You must mount a module using holes arranged in four corners or four sides.
- (2) You should consider the mounting structure so that uneven force (ex. Twisted stress) is not applied to the module. And the case on which a module is mounted should have sufficient strength so that external force is not transmitted directly to the module.
- (3) Please attach the surface transparent protective plate to the surface in order to protect the polarizer. Transparent protective plate should have sufficient strength in order to resist external force.
- (4) You should adopt radiation structure to satisfy the temperature specification.
- (5) Acetic acid type and chlorine type materials for the cover case are not desirable because the former generates corrosive gas of attacking the polarizer at high temperature and the latter causes circuit break by electro-chemical reaction.
- (6) Do not touch, push or rub the exposed polarizers with glass, tweezers or anything harder than HB pencil lead. And please do not rub with dust clothes with chemical treatment. Do not touch the surface of polarizer for bare hand or greasy cloth.(Some cosmetics are detrimental to the polarizer.)
- (7) When the surface becomes dusty, please wipe gently with absorbent cotton or other soft materials like chamois soaks with petroleum benzene. Normal-hexane is recommended for cleaning the adhesives used to attach front / rear polarizers. Do not use acetone, toluene and alcohol because they cause chemical damage to the polarizer.
- (8) Wipe off saliva or water drops as soon as possible. Their long time contact with polarizer causes deformations and color fading.
- (9) Do not open the case because inside circuits do not have sufficient strength.
- (10) As The IPS panel is sensitive & slim, please recommend the metal frame of the system supports the panel by the double side-mount.

#### 9-2. OPERATING PRECAUTIONS

- (1) The spike noise causes the mis-operation of circuits. It should be lower than following voltage :  
 $V = \pm 200\text{mV}$  (Over and under shoot voltage)
- (2) Response time depends on the temperature.(In lower temperature, it becomes longer.)
- (3) Brightness depends on the temperature. (In Higher temperature, it becomes lower.)  
 And in lower temperature, response time(required time that brightness is stable after turned on) becomes longer.
- (4) Be careful for condensation at sudden temperature change. Condensation makes damage to polarizer or electrical contacted parts. And after fading condensation, smear or spot will occur.
- (5) When fixed patterns are displayed for a long time, remnant image is likely to occur.
- (6) Module has high frequency circuits. Sufficient suppression to the electromagnetic interference shall be done by system manufacturers. Grounding and shielding methods may be important to minimized the interference.
- (7) Please do not give any mechanical and/or acoustical impact to LCM. Otherwise, LCM can't be operated its full characteristics perfectly.
- (8) A screw which is fastened up the steels should be a machine screw.  
 (if not, it causes metallic foreign material and deal LCM a fatal blow)
- (9) Please do not set LCD on its edge.
- (10) When LCMs are used for public display defects such as Yogore, image sticking can not be guarantee.
- (11) LCMs cannot support "Interlaced Scan Method"
- (12) Please conduct image sticking test after 2-hour aging with Rolling PTN and normal temperature(25~40°C)



## Product Specification

**9-3. ELECTROSTATIC DISCHARGE CONTROL**

Since a module is composed of electronic circuits, it is not strong to electrostatic discharge. Make certain that treatment persons are connected to ground through wrist band etc. And don't touch interface pin directly.

**9-4. PRECAUTIONS FOR STRONG LIGHT EXPOSURE**

Strong light exposure causes degradation of polarizer and color filter.

**9-5. STORAGE**

When storing modules as spares for a long time, the following precautions are necessary.

- (1) Store them in a dark place. Do not expose the module to sunlight or fluorescent light. Keep the temperature between 5°C and 35°C at normal humidity.
- (2) The polarizer surface should not come in contact with any other object.  
It is recommended that they be stored in the container in which they were shipped.

**9-6. HANDLING PRECAUTIONS FOR PROTECTION FILM**

- (1) The protection film is attached to the bezel with a small masking tape.  
When the protection film is peeled off, static electricity is generated between the film and polarizer.  
This should be peeled off slowly and carefully by people who are electrically grounded and with well ion-blown equipment or in such a condition, etc.
- (2) When the module with protection film attached is stored for a long time, sometimes there remains a very small amount of glue still on the bezel after the protection film is peeled off.
- (3) You can remove the glue easily. When the glue remains on the bezel surface or its vestige is recognized, please wipe them off with absorbent cotton waste or other soft material like chamois soaked with normal-hexane.