

TFT-Display Datenblatt

Modell LM190E09-TLB1

Kurzdaten

| | |
|-------------|---------------------------|
| Hersteller | LG Display |
| Diagonale | 19" / 48,3cm |
| Format | 5:4 |
| Auflösung | 1280x1024 |
| Backlight | LED/ 250cd/m ² |
| Interface | LVDS |
| Touchscreen | nein |
| Temperatur | 0...+50°C (Betrieb) |

Product Specification

SPECIFICATION FOR APPROVAL

(◆) Preliminary Specification
() Final Specification

| | |
|-------|--------------------|
| Title | 19.0" SXGA TFT LCD |
|-------|--------------------|

| | |
|-------|---------|
| BUYER | General |
| MODEL | |

| | |
|----------|----------------------|
| SUPPLIER | LG Display Co., Ltd. |
| *MODEL | LM190E09 |
| SUFFIX | TLB1 |

*When you obtain standard approval,
please use the above model name without suffix

| SIGNATURE | DATE |
|-----------|-------|
| / | _____ |
| / | _____ |
| / | _____ |

Please return 1 copy for your confirmation
With your signature and comments.

| APPROVED BY | DATE |
|--------------------|-------|
| / G.Manager | _____ |
| REVIEWED BY | |
| / Manager [C] | _____ |
| / Manager [M] | _____ |
| / Manager [P] | _____ |
| PREPARED BY | |
| / Engineer | _____ |

**Product Engineering Dept.
LG Display Co., Ltd**

Product Specification
Contents

| No | ITEM | Page |
|----|---|------|
| | COVER | 1 |
| | CONTENTS | 2 |
| | RECORD OF REVISIONS | 3 |
| 1 | GENERAL DESCRIPTION | 4 |
| 2 | ABSOLUTE MAXIMUM RATINGS | 5 |
| 3 | ELECTRICAL SPECIFICATIONS | 6 |
| | 1) ELECTRICAL CHARACTERISTICS | 6 |
| | 2) INTERFACE CONNECTIONS | 8 |
| | 3) LVDS characteristics | 11 |
| | 4) SIGNAL TIMING SPECIFICATIONS | 14 |
| | 5) SIGNAL TIMING WAVEFORMS | 15 |
| | 6) COLOR INPUT DATA REFERNECE | 16 |
| | 7) POWER SEQUENCE | 17 |
| | 8) POWER DIP CONDITION | 18 |
| 4 | OPTICAL SFECIFICATIONS | 19 |
| 5 | MECHANICAL CHARACTERISTICS | 23 |
| 6 | RELIABILITY | 26 |
| 7 | INTERNATIONAL STANDARDS | 27 |
| | 1) SAFETY | 27 |
| | 2) EMC | 27 |
| | 3) ENVIRONMENT | 27 |
| 8 | PACKING | 28 |
| | 1) DESIGNATION OF LOT MARK | 28 |
| | 2) PACKING FORM | 28 |
| 9 | PRECAUTIONS | 29 |
| | 1) MOUNTING PRECAUTIONS | 29 |
| | 2) OPERATING PRECAUTIONS | 29 |
| | 3) ELECTROSTATIC DISCHARGE CONTROL | 30 |
| | 4) PRECAUTIONS FOR STRONG LIGHT EXPOSURE | 30 |
| | 5) STROAGE | 30 |
| | 6) HANDLING PRECAUTIONS FOR PROTECTION FILM | 30 |

Product Specification

1. General description

LM190E09-TLB1 is a Color Active Matrix Liquid Crystal Display with Light Emitting Diode(White LED) backlight system without LED driver. The matrix employs a-Si Thin Film Transistor as the active element. It is a transmissive type display operating in the normally white mode. It has a 19.0 inch diagonally measured active display area with SXGA resolution (1024 vertical by 1280 horizontal pixel array) Each pixel is divided into Red, Green and Blue sub-pixels or dots which are arranged in vertical stripes. Gray scale or the brightness of the sub-pixel color is determined with a 8-bit gray scale signal for each dot, thus, presenting a palette of more than 16,7M colors with Advanced-FRC(Frame Rate Control). It has been designed to apply the interface method that enables low power, high speed, low EMI. FPD Link or compatible must be used as a LVDS(Low Voltage Differential Signaling) chip. It is intended to support applications where thin thickness, wide viewing angle, low power are critical factors and graphic displays are important. In combination with the vertical arrangement of the sub-pixels, the LM190E09-TLB1 characteristics provide an excellent flat panel display for office automation products such as monitors.

FIG. 1 Block diagram

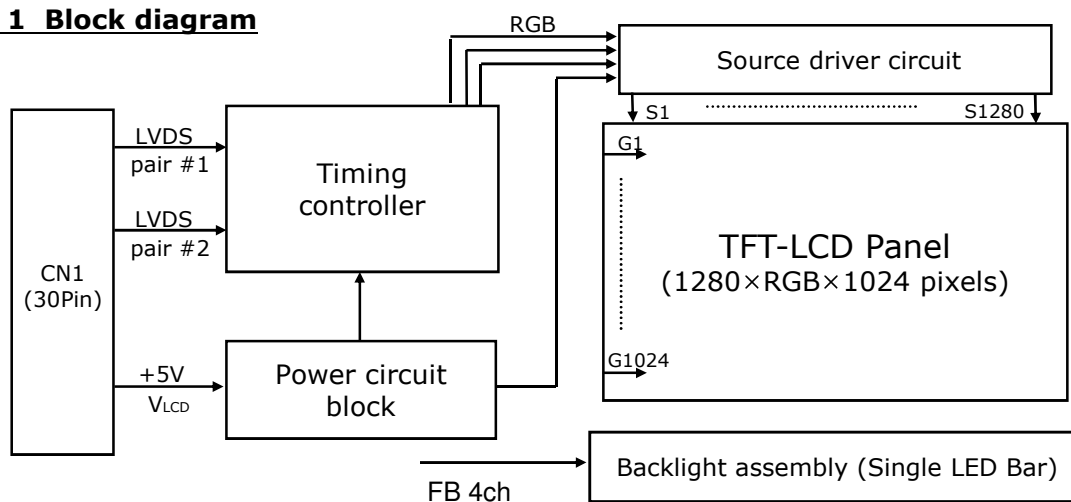

General features

| | |
|------------------------|---|
| Active screen size | 19.0 inches (481.9mm) diagonal |
| Outline Dimension | 396.0(H) x 324.0(V) x 9.9(D) mm(Typ.) |
| Pixel Pitch | 0.098*RGB(H)mm x 0.294(V)mm |
| Pixel Format | 1280 horizontal By 1024 vertical Pixels. RGB stripe arrangement |
| Interface | LVDS 2Port |
| Color depth | 16.7M colors |
| Luminance, white | 250 cd/m ² (Center 1Point, typ) |
| Viewing Angle (CR>10) | R/L 170(Typ.), U/D 160(Typ.) |
| Power Consumption | Total 17.19W(Typ.), (4.9W@V _{LCD} , 12.29W_w/o driver) |
| Weight | 1250g (Typ.) |
| Display operating mode | Transmissive mode, normally White |
| Surface treatments | Hard coating (3H), Anti-glare treatment of the front polarizer |

Product Specification

2. Absolute maximum ratings

The following are maximum values which, if exceeded, may cause faulty operation or damage to the unit.

Table 1. Absolute maximum ratings

| Parameter | Symbol | Values | | Units | Notes |
|----------------------------|-----------|--------|------|-------|---------|
| | | Min | Max | | |
| Power Supply Input Voltage | V_{LCD} | -0.3 | +6.0 | Vdc | At 25°C |
| Operating Temperature | T_{OP} | 0 | 50 | °C | 1 |
| Storage Temperature | T_{ST} | -20 | 60 | °C | |
| Operating Ambient Humidity | H_{OP} | 10 | 90 | %RH | |
| Storage Humidity | H_{ST} | 10 | 90 | %RH | |

- Note : 1. Temperature and relative humidity range are shown in the figure below.
 Wet bulb temperature should be 39 °C Max, and no condensation of water.
 2. Maximum Storage Humidity is up to 40°C, 90% RH only for 4 corner light leakage Mura.
 3. Storage condition is guaranteed under packing condition

FIG. 2 Temperature and relative humidity

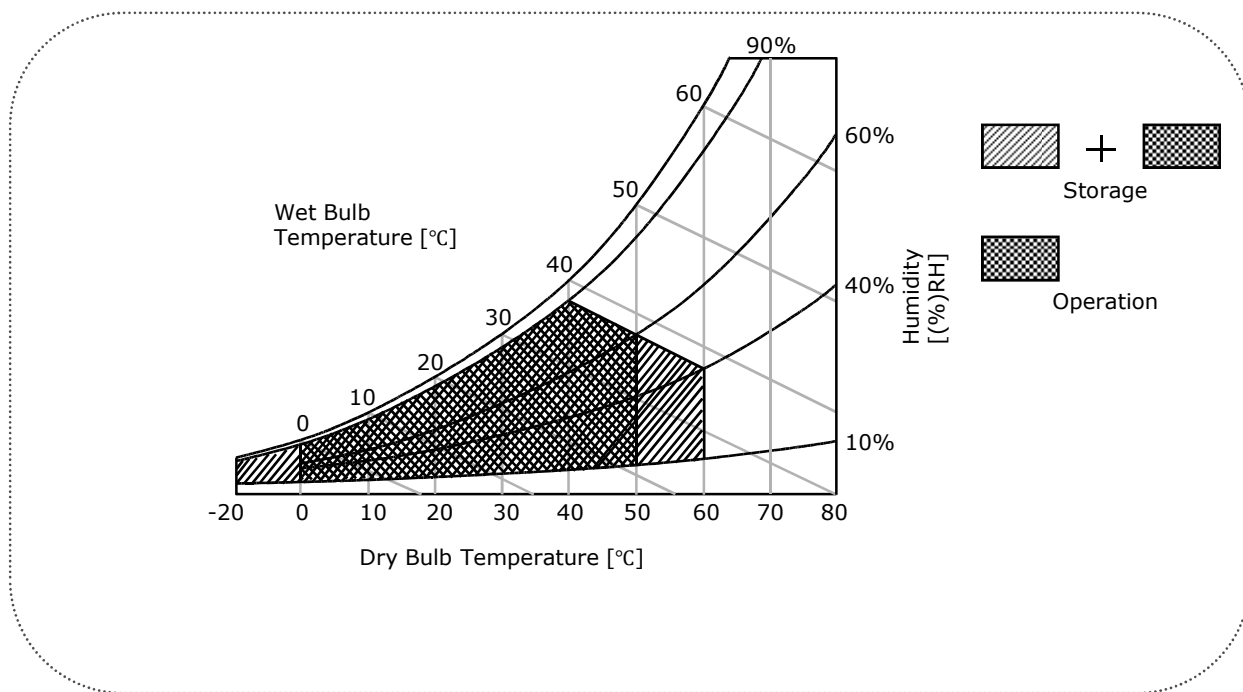

Product Specification

3. Electrical specifications

3-1. Electrical characteristics

It requires two power inputs. One is employed to power the LCD electronics and to drive the TFT array and liquid crystal. The second input power for the LED/Backlight, is typically generated by a LED Driver. The LED Driver is an external unit to the LCDs.

Table 2. Electrical characteristics

| Parameter | Symbol | Values | | | Unit | Notes |
|-------------------------------|------------------|--------|------|------|------|-------|
| | | Min | Typ | Max | | |
| MODULE : | | | | | | |
| Power Supply Input Voltage | V_{LCD} | 4.5 | 5.0 | 5.5 | Vdc | |
| Permissive Power Input Ripple | V_{LCD} | - | - | 0.2 | V | 3 |
| Power Supply Input Current | $I_{LCD-MOSAIC}$ | - | 980 | 1130 | mA | 1 |
| | $I_{LCD-BLACK}$ | - | 1140 | 1305 | mA | 2 |
| Power Consumption | P_{LCD} | - | 4.90 | 5.65 | Watt | 1 |
| Inrush current | I_{RUSH} | - | - | 3.0 | A | 3 |

Note :

1. The specified current and power consumption are under the $V_{LCD}=5.0V$, $25 \pm 2^{\circ}C$, $f_v=60Hz$ condition whereas mosaic pattern(8 x 6) is displayed and f_v is the frame frequency.
2. The current is specified at the maximum current pattern.
3. Permissive power ripple should be measured under $VCC=5.0V$, $25^{\circ}C$, f_v (frame frequency)=75Hz condition and At that time, we recommend the bandwidth configuration of oscilloscope is to be under 20MHz.
4. The duration of rush current is about 2ms and rising time of power Input is $500us \pm 20\%$.

FIG.3 pattern for Electrical characteristics

power consumption measurement

White : 255Gray
Black : 0Gray

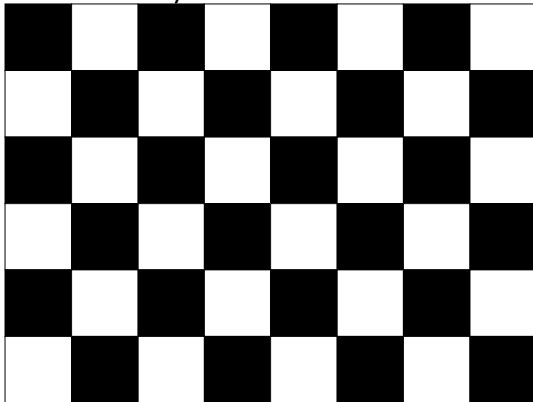

Mosaic Pattern(8 x 6)

power input ripple



Full Black Pattern

Product Specification
Table 3. LED Bar Electrical characteristics

| Parameter | Symbol | Values | | | Unit | Notes |
|--------------------|-----------|--------|-------|-------|------|-------|
| | | Min | Typ | Max | | |
| LED : | | | | | | 1,7 |
| LED String Current | I_S | - | 60 | 65 | mA | 2,7 |
| LED String Voltage | V_S | 48 | 51.2 | 56 | V | 3,7 |
| Power Consumption | P_{BAR} | 11.52 | 12.29 | 13.44 | Watt | 4,6,7 |
| LED Life Time | LED_LT | 30,000 | - | - | Hrs | 5,7 |

LED driver design guide

: The design of the LED driver must have specifications for the LED in LCD Assembly. The performance of the LED in LCM, for example life time or brightness, is extremely influenced by the characteristics of the LED driver.

So all the parameters of an LED driver should be carefully designed and output current should be Constant current control.

Please control feedback current of each string individually to compensate the current variation among the strings of LEDs.

When you design or order the LED driver, please make sure unwanted lighting caused by the mismatch of the LED and the LED driver (no lighting, flicker, etc) never occurs.

When you confirm it, the LCD module should be operated in the same condition as installed in your instrument.

- Specified values are for a single LED bar.
- The specified current is input LED chip 100% duty current.
- The specified voltage is input LED string and Bar voltage at typical 60mA 100% duty current.
- The specified power consumption is input LED bar power consumption at typical 60mA 100% duty current.
- The life is determined as the time at which luminance of the LED is 50% compared to that of initial value at the typical LED current on condition of continuous operating at $25 \pm 2^\circ\text{C}$.
- The LED bar power consumption shown above does not include loss of external driver. The used LED bar current is the LED typical current.
 Min Power Consumption is calculated with $P_{Bar} = V_s(\text{Min.}) \times I_s(\text{Typ.}) \times N_{string}$
 Max Power Consumption is calculated with $P_{Bar} = V_{bar}(\text{Max.}) \times I_s(\text{Typ.}) \times N_{string}$
- LED operating DC Forward Current must not exceed LED Max Ratings at $25 \pm 2^\circ\text{C}$

Product Specification
3-2. Interface connections

LCD connector(CN1) : GT103-30S-H15 (LSM), IS100-L300-C23(UJU)

Mating connector : FI-X30H and FI-X30HL (JAE) or Equivalent

Table 4. Module connector(CN1) pin configuration

| Pin No | Symbol | Description |
|--------|------------------|--|
| 1 | RX00- | Minus signal of 1st channel 0 (LVDS) |
| 2 | RX00+ | Plus signal of 1st channel 0 (LVDS) |
| 3 | RX01- | Minus signal of 1st channel 1 (LVDS) |
| 4 | RX01+ | Plus signal of 1st channel 1 (LVDS) |
| 5 | RX02- | Minus signal of 1st channel 2 (LVDS) |
| 6 | RX02+ | Plus signal of 1st channel 2 (LVDS) |
| 7 | GND | Ground |
| 8 | RXOC- | Minus signal of 1st clock channel (LVDS) |
| 9 | RXOC+ | Plus signal of 1st clock channel (LVDS) |
| 10 | RX03- | Minus signal of 1st channel 3 (LVDS) |
| 11 | RX03+ | Plus signal of 1st channel 3 (LVDS) |
| 12 | RXE0- | Minus signal of 2nd channel 0 (LVDS) |
| 13 | RXE0+ | Plus signal of 2nd channel 0 (LVDS) |
| 14 | GND | Ground |
| 15 | RXE1- | Minus signal of 2nd channel 1 (LVDS) |
| 16 | RXE1+ | Plus signal of 2nd channel 1 (LVDS) |
| 17 | GND | Ground |
| 18 | RXE2- | Minus signal of 2nd channel 2 (LVDS) |
| 19 | RXE2+ | Plus signal of 2nd channel 2 (LVDS) |
| 20 | RXEC- | Minus signal of 2nd clock channel (LVDS) |
| 21 | RXEC+ | Plus signal of 2nd clock channel (LVDS) |
| 22 | RXE3- | Minus signal of 2nd channel 3 (LVDS) |
| 23 | RXE3+ | Plus signal of 2nd channel 3 (LVDS) |
| 24 | GND | Ground |
| 25 | NC | No Connection (For LCD internal use only.) |
| 26 | NC | No Connection (For LCD internal use only.) |
| 27 | NC | No Connection (For LCD internal use only.) |
| 28 | V _{LCD} | Power Supply (5.0V) |
| 29 | V _{LCD} | Power Supply (5.0V) |
| 30 | V _{LCD} | Power Supply (5.0V) |

First Pixel data

Second Pixel data

Product Specification

FIG. 4 Connector diagram

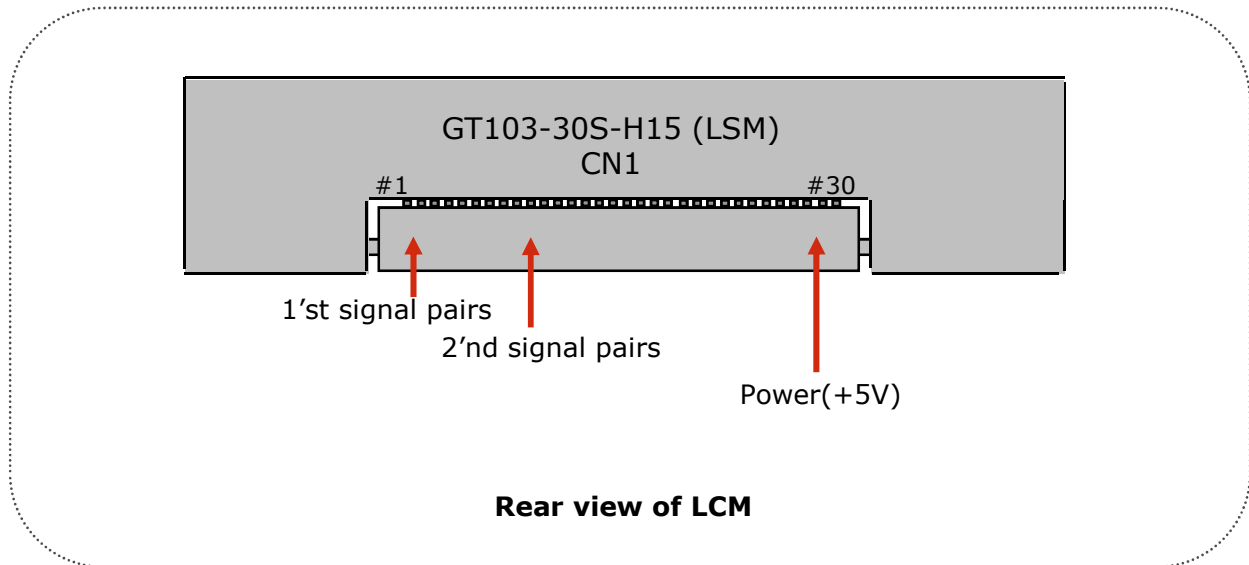

Note:

1. NC: No Connection.
2. All GND(ground) pins should be connected together and to Vss which should also be connected to the LCD's metal frame.
3. All V_{LCD} (power input) pins should be connected together.
4. Input Level of LVDS signal is based on the IEA 664 Standard.

Product Specification

The LED interface connector is a model **10019HR-H06B** manufactured by YEONHO.
The mating connector part number are TBD or equivalent.
The pin configuration for the connector is shown in the table below.

Table 5. LED connector pin configuration

| Pin | Symbol | Description | Notes |
|-----|--------|----------------------------|-------|
| 1 | FB1 | Channel1 Current Feed Back | |
| 2 | FB2 | Channel2 Current Feed Back | |
| 3 | Vled1 | LED Power Supply | |
| 4 | Vled2 | LED Power Supply | |
| 5 | FB3 | Channel3 Current Feed Back | |
| 6 | FB4 | Channel4 Current Feed Back | |

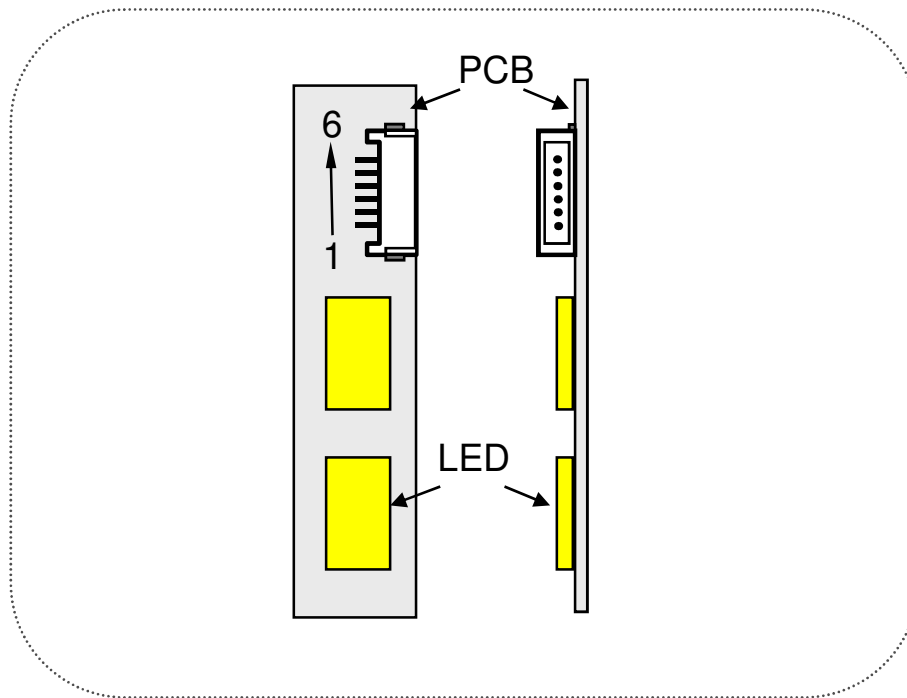
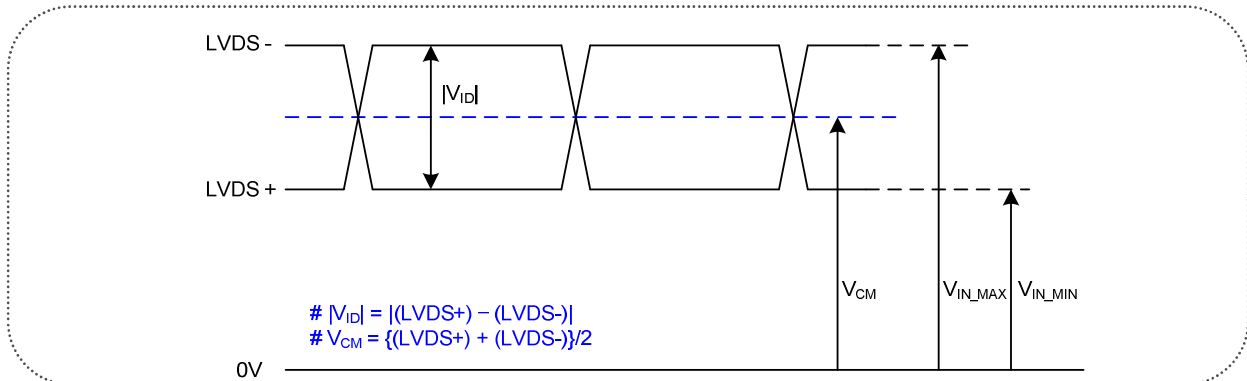

FIG. 5 Backlight connector view

Product Specification

3-3. LVDS characteristics

3-3-1. DC Specification



| Description | Symbol | Min | Max | Unit | Notes |
|---------------------------|------------|-----|-----|------|-------|
| LVDS Differential Voltage | $ V_{ID} $ | 200 | 600 | mV | - |
| LVDS Common mode Voltage | V_{CM} | 0.6 | 1.8 | V | - |
| LVDS Input Voltage Range | V_{IN} | 0.3 | 2.1 | V | - |

3-3-2. AC Specification

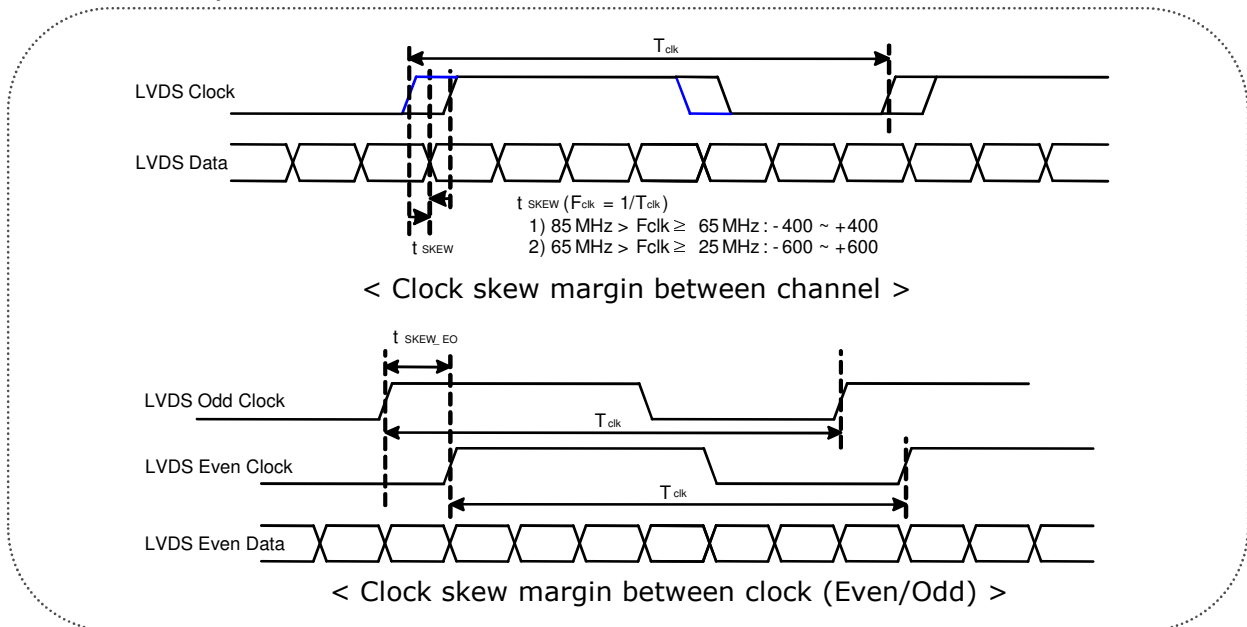

| Description | Symbol | Min | Max | Unit | Notes |
|---|----------------|-------|-------|-----------|----------------------|
| LVDS Clock to Data Skew Margin | t_{SKEW} | - 400 | + 400 | ps | 85MHz > Fclk ≥ 65MHz |
| | t_{SKEW} | - 600 | + 600 | ps | 65MHz > Fclk ≥ 25MHz |
| LVDS Clock to Clock Skew Margin (Even to Odd) | t_{SKEW_EO} | - 1/7 | + 1/7 | T_{clk} | - |

Product Specification

3-3-3. LVDS Data format

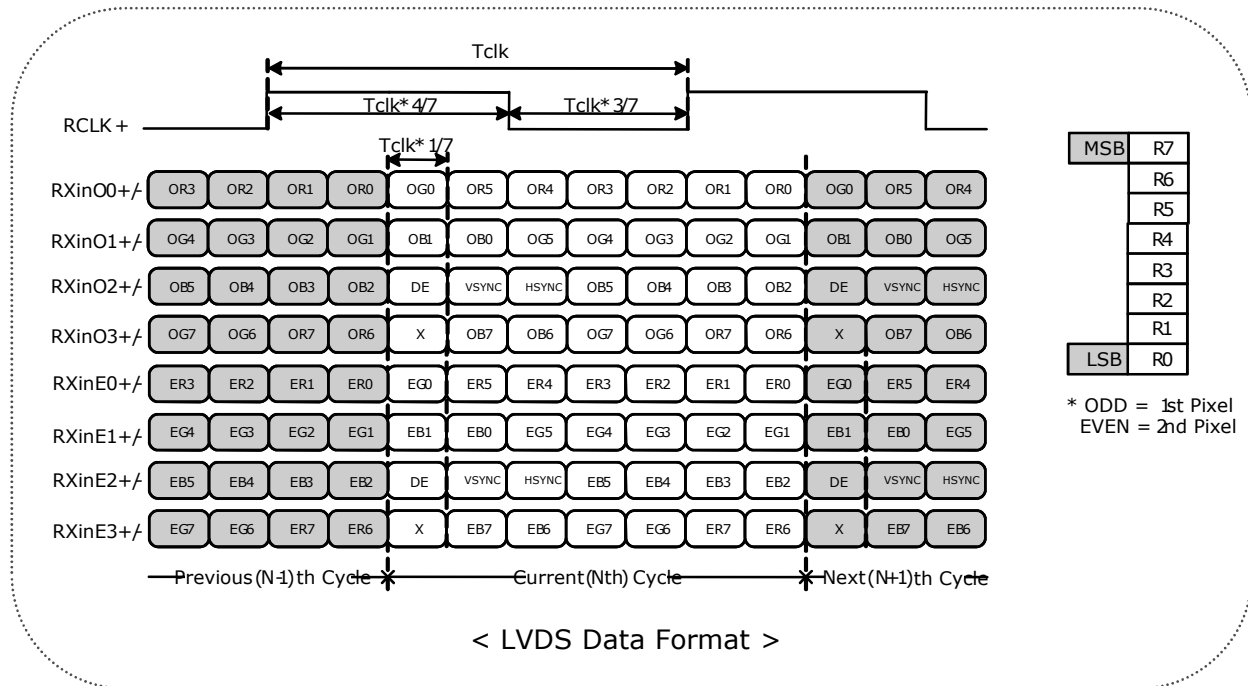

Product Specification
Table 6. Required signal assignment for Flat Link(NS:DS90CF383) transmitter

| Pin # | Pin Name | Require Signal | Pin # | Pin Name | Require Signal |
|-------|----------|----------------------------|-------|------------------------|--|
| 1 | VCC | Power Supply for TTL Input | 29 | GND | Ground pin for TTL |
| 2 | D5 | TTL Input (R7) | 30 | D26 | TTL Input (DE) |
| 3 | D6 | TTL Input (R5) | 31 | T _x CLKIN | TTL Level clock Input |
| 4 | D7 | TTL Input (G0) | 32 | PWR DWN | Power Down Input |
| 5 | GND | Ground pin for TTL | 33 | PLL GND | Ground pin for PLL |
| 6 | D8 | TTL Input (G1) | 34 | PLL VCC | Power Supply for PLL |
| 7 | D9 | TTL Input (G2) | 35 | PLL GND | Ground pin for PLL |
| 8 | D10 | TTL Input (G6) | 36 | LVDS GND | Ground pin for LVDS |
| 9 | VCC | Power Supply for TTL Input | 37 | T _x OUT3+ | Positive LVDS differential data output 3 |
| 10 | D11 | TTL Input (G7) | 38 | T _x OUT3- | Negative LVDS differential data output 3 |
| 11 | D12 | TTL Input (G3) | 39 | T _x CLKOUT+ | Positive LVDS differential clock output |
| 12 | D13 | TTL Input (G4) | 40 | T _x CLKOUT- | Negative LVDS differential clock output |
| 13 | GND | Ground pin for TTL | 41 | T _x OUT2+ | Positive LVDS differential data output 2 |
| 14 | D14 | TTL Input (G5) | 42 | T _x OUT2- | Negative LVDS differential data output 2 |
| 15 | D15 | TTL Input (B0) | 43 | LVDS GND | Ground pin for LVDS |
| 16 | D16 | TTL Input (B6) | 44 | LVDS VCC | Power Supply for LVDS |
| 17 | VCC | Power Supply for TTL Input | 45 | T _x OUT1+ | Positive LVDS differential data output 1 |
| 18 | D17 | TTL Input (B7) | 46 | T _x OUT1- | Negative LVDS differential data output 1 |
| 19 | D18 | TTL Input (B1) | 47 | T _x OUT0+ | Positive LVDS differential data output 0 |
| 20 | D19 | TTL Input (B2) | 48 | T _x OUT0- | Negative LVDS differential data output 0 |
| 21 | GND | Ground pin for TTL Input | 49 | LVDS GND | Ground pin for LVDS |
| 22 | D20 | TTL Input (B3) | 50 | D27 | TTL Input (R6) |
| 23 | D21 | TTL Input (B4) | 51 | D0 | TTL Input (R0) |
| 24 | D22 | TTL Input (B5) | 52 | D1 | TTL Input (R1) |
| 25 | D23 | TTL Input (RSVD) | 53 | GND | Ground pin for TTL |
| 26 | VCC | Power Supply for TTL Input | 54 | D2 | TTL Input (R2) |
| 27 | D24 | TTL Input (HSYNC) | 55 | D3 | TTL Input (R3) |
| 28 | D25 | TTL Input (VSYNC) | 56 | D4 | TTL Input (R4) |

Notes : Refer to LVDS Transmitter Data Sheet for detail descriptions.

Product Specification

3-4. Signal timing specifications

This is the signal timing required at the input of the User connector. All of the interface signal timing should be satisfied with the following specifications for it's proper operation.

Table 7. Timing table

| Parameter | | Symbol | Min. | Typ. | Max. | Unit | Notes |
|------------------|------------------------|------------------|------|------|------|------------------|---------------------------------|
| D _{CLK} | Period | t _{CLK} | 14.8 | 18.5 | 22.2 | ns | Pixel frequency : Typ.108MHz |
| | Frequency | f _{CLK} | 45.0 | 54.0 | 67.5 | MHz | |
| Horizontal | Horizontal Valid | t _{HV} | 640 | 640 | 640 | t _{CLK} | |
| | H Period Total | t _{HP} | 704 | 844 | 960 | | |
| | Horizontal Blank | t _{HB} | 64 | 204 | 320 | | |
| | Hsync Frequency | f _H | 53.3 | 64.0 | 80.0 | kHz | |
| | Width | t _{WH} | 16 | 56 | 80 | t _{CLK} | |
| | Horizontal Back Porch | t _{HBP} | 32 | 124 | 200 | | |
| | Horizontal Front Porch | t _{HFP} | 16 | 24 | 40 | | |
| Vertical | Vertical Valid | t _{VV} | 1024 | 1024 | 1024 | t _{HP} | |
| | V Period Total | t _{VP} | 1032 | 1066 | 1536 | | |
| | Vertical Blank | t _{VB} | 8 | 42 | 512 | | |
| | Vsync Frequency | f _V | 50 | 60 | 75 | Hz | |
| | Width | t _{VVV} | 2 | 3 | 250 | t _{HP} | |
| | Vertical Back Porch | t _{VBP} | 5 | 38 | 250 | | |
| | Vertical Front Porch | t _{VFP} | 1 | 1 | 12 | | |

Note: Hsync period and Hsync width-active should be even number times of t_{CLK}. If the value is odd number times of t_{CLK}, display control signal can be asynchronous. In order to operate this LCM a Hsync, Vsyn, and DE(data enable) signals should be used.

1. The performance of the electro-optical characteristics may be influenced by variance of the vertical refresh rates.
2. Vsync and Hsync should be keep the above specification.
3. Hsync Period, Hsync Width, and Horizontal Back Porch should be any times of of character number(4).
4. The polarity of Hsync, Vsync is not restricted.

Product Specification

3-5. Signal timing waveforms

1. Dclk, DE, DATA waveforms

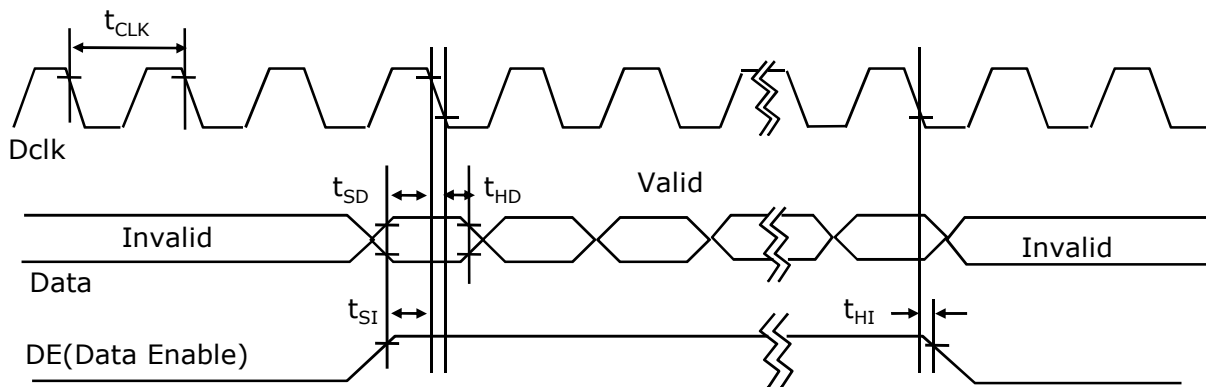

2. Horizontal waveform

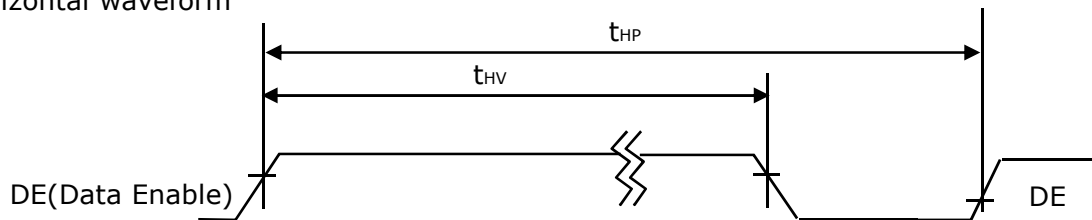

3. Vertical waveform

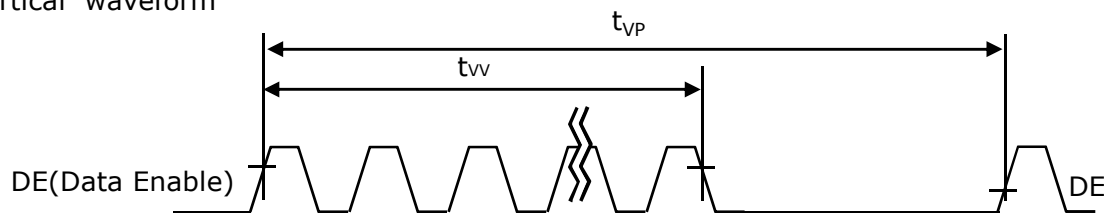

Product Specification
3-6. Color input data reference

The brightness of each primary color (red, green and blue) is based on the 8bit gray scale data input for the color ; the higher the binary input, the brighter the color. The table below provides a reference for color versus data input.

Table 8. Color data reference

| Color | | Input Color Data | | | | | | | | | | | | | | | | | | | | | | | |
|-------------|------------------|------------------|----|----|----|-----|----|----|----|-------|----|----|----|-----|----|----|----|------|----|----|----|-----|----|----|----|
| | | Red | | | | | | | | Green | | | | | | | | Blue | | | | | | | |
| | | MSB | | | | LSB | | | | MSB | | | | LSB | | | | MSB | | | | LSB | | | |
| | | R7 | R6 | R5 | R4 | R3 | R2 | R1 | R0 | G7 | G6 | G5 | G4 | G3 | G2 | G1 | G0 | B7 | B6 | B5 | B4 | B3 | B2 | B1 | B0 |
| Basic Color | Black | 0 | 0 | 0 | 0 | 0 | 0 | 0 | 0 | 0 | 0 | 0 | 0 | 0 | 0 | 0 | 0 | 0 | 0 | 0 | 0 | 0 | 0 | 0 | 0 |
| | Red (255) | 1 | 1 | 1 | 1 | 1 | 1 | 1 | 1 | 0 | 0 | 0 | 0 | 0 | 0 | 0 | 0 | 0 | 0 | 0 | 0 | 0 | 0 | 0 | 0 |
| | Green (255) | 0 | 0 | 0 | 0 | 0 | 0 | 0 | 0 | 1 | 1 | 1 | 1 | 1 | 1 | 1 | 1 | 0 | 0 | 0 | 0 | 0 | 0 | 0 | 0 |
| | Blue (255) | 0 | 0 | 0 | 0 | 0 | 0 | 0 | 0 | 0 | 0 | 0 | 0 | 0 | 0 | 0 | 0 | 1 | 1 | 1 | 1 | 1 | 1 | 1 | 1 |
| | Cyan | 0 | 0 | 0 | 0 | 0 | 0 | 0 | 0 | 1 | 1 | 1 | 1 | 1 | 1 | 1 | 1 | 1 | 1 | 1 | 1 | 1 | 1 | 1 | 1 |
| | Magenta | 1 | 1 | 1 | 1 | 1 | 1 | 1 | 1 | 0 | 0 | 0 | 0 | 0 | 0 | 0 | 0 | 1 | 1 | 1 | 1 | 1 | 1 | 1 | 1 |
| | Yellow | 1 | 1 | 1 | 1 | 1 | 1 | 1 | 1 | 1 | 1 | 1 | 1 | 1 | 1 | 1 | 1 | 0 | 0 | 0 | 0 | 0 | 0 | 0 | 0 |
| | White | 1 | 1 | 1 | 1 | 1 | 1 | 1 | 1 | 1 | 1 | 1 | 1 | 1 | 1 | 1 | 1 | 1 | 1 | 1 | 1 | 1 | 1 | 1 | 1 |
| Red | Red(000) Dark | 0 | 0 | 0 | 0 | 0 | 0 | 0 | 0 | 0 | 0 | 0 | 0 | 0 | 0 | 0 | 0 | 0 | 0 | 0 | 0 | 0 | 0 | 0 | 0 |
| | Red(001) | 0 | 0 | 0 | 0 | 0 | 0 | 0 | 1 | 0 | 0 | 0 | 0 | 0 | 0 | 0 | 0 | 0 | 0 | 0 | 0 | 0 | 0 | 0 | 0 |
| | Red(002) | 0 | 0 | 0 | 0 | 0 | 0 | 1 | 0 | 0 | 0 | 0 | 0 | 0 | 0 | 0 | 0 | 0 | 0 | 0 | 0 | 0 | 0 | 0 | 0 |
| | ----- | - | - | - | - | - | - | - | - | - | - | - | - | - | - | - | - | - | - | - | - | - | - | - | - |
| | ----- | - | - | - | - | - | - | - | - | - | - | - | - | - | - | - | - | - | - | - | - | - | - | - | - |
| | Red(253) | 1 | 1 | 1 | 1 | 1 | 1 | 0 | 1 | 0 | 0 | 0 | 0 | 0 | 0 | 0 | 0 | 0 | 0 | 0 | 0 | 0 | 0 | 0 | 0 |
| | Red(254) | 1 | 1 | 1 | 1 | 1 | 1 | 1 | 0 | 0 | 0 | 0 | 0 | 0 | 0 | 0 | 0 | 0 | 0 | 0 | 0 | 0 | 0 | 0 | 0 |
| | Red(255) Bright | 1 | 1 | 1 | 1 | 1 | 1 | 1 | 1 | 0 | 0 | 0 | 0 | 0 | 0 | 0 | 0 | 0 | 0 | 0 | 0 | 0 | 0 | 0 | 0 |
| Green | Green(000) Dark | 0 | 0 | 0 | 0 | 0 | 0 | 0 | 0 | 0 | 0 | 0 | 0 | 0 | 0 | 0 | 0 | 0 | 0 | 0 | 0 | 0 | 0 | 0 | 0 |
| | Green(001) | 0 | 0 | 0 | 0 | 0 | 0 | 0 | 0 | 0 | 0 | 0 | 0 | 0 | 0 | 1 | 0 | 0 | 0 | 0 | 0 | 0 | 0 | 0 | 0 |
| | Green(002) | 0 | 0 | 0 | 0 | 0 | 0 | 0 | 0 | 0 | 0 | 0 | 0 | 0 | 0 | 1 | 0 | 0 | 0 | 0 | 0 | 0 | 0 | 0 | 0 |
| | ----- | - | - | - | - | - | - | - | - | - | - | - | - | - | - | - | - | - | - | - | - | - | - | - | - |
| | ----- | - | - | - | - | - | - | - | - | - | - | - | - | - | - | - | - | - | - | - | - | - | - | - | - |
| | Green(253) | 0 | 0 | 0 | 0 | 0 | 0 | 0 | 0 | 1 | 1 | 1 | 1 | 1 | 1 | 0 | 1 | 0 | 0 | 0 | 0 | 0 | 0 | 0 | 0 |
| | Green(254) | 0 | 0 | 0 | 0 | 0 | 0 | 0 | 0 | 1 | 1 | 1 | 1 | 1 | 1 | 1 | 0 | 0 | 0 | 0 | 0 | 0 | 0 | 0 | 0 |
| | Green(255)Bright | 0 | 0 | 0 | 0 | 0 | 0 | 0 | 0 | 1 | 1 | 1 | 1 | 1 | 1 | 1 | 1 | 0 | 0 | 0 | 0 | 0 | 0 | 0 | 0 |
| Blue | Blue(000) Dark | 0 | 0 | 0 | 0 | 0 | 0 | 0 | 0 | 0 | 0 | 0 | 0 | 0 | 0 | 0 | 0 | 0 | 0 | 0 | 0 | 0 | 0 | 0 | 0 |
| | Blue(001) | 0 | 0 | 0 | 0 | 0 | 0 | 0 | 0 | 0 | 0 | 0 | 0 | 0 | 0 | 0 | 0 | 0 | 0 | 0 | 0 | 0 | 0 | 0 | 1 |
| | Blue(002) | 0 | 0 | 0 | 0 | 0 | 0 | 0 | 0 | 0 | 0 | 0 | 0 | 0 | 0 | 0 | 0 | 0 | 0 | 0 | 0 | 0 | 0 | 1 | 0 |
| | ----- | - | - | - | - | - | - | - | - | - | - | - | - | - | - | - | - | - | - | - | - | - | - | - | - |
| | ----- | - | - | - | - | - | - | - | - | - | - | - | - | - | - | - | - | - | - | - | - | - | - | - | - |
| | Blue(253) | 0 | 0 | 0 | 0 | 0 | 0 | 0 | 0 | 0 | 0 | 0 | 0 | 0 | 0 | 0 | 1 | 1 | 1 | 1 | 1 | 1 | 1 | 0 | 1 |
| | Blue(254) | 0 | 0 | 0 | 0 | 0 | 0 | 0 | 0 | 0 | 0 | 0 | 0 | 0 | 0 | 0 | 1 | 1 | 1 | 1 | 1 | 1 | 1 | 1 | 0 |
| | Blue(255) Bright | 0 | 0 | 0 | 0 | 0 | 0 | 0 | 0 | 0 | 0 | 0 | 0 | 0 | 0 | 0 | 1 | 1 | 1 | 1 | 1 | 1 | 1 | 1 | 1 |

Product Specification

3-7. Power sequence

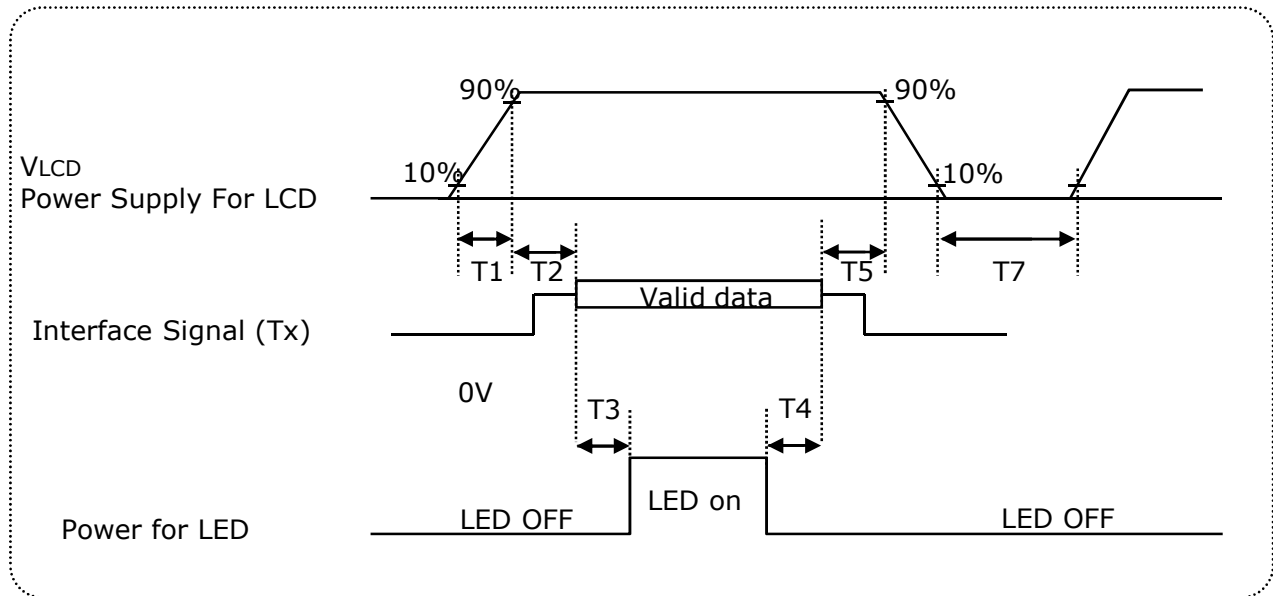

Table 9. Power sequence

| Parameter | Values | | | Units |
|-----------|--------|-----|-----|-------|
| | Min | Typ | Max | |
| T1 | 0.5 | - | 10 | ms |
| T2 | 0.01 | - | 50 | ms |
| T3 | 500 | - | - | ms |
| T4 | 200 | - | - | ms |
| T5 | 0.01 | - | 50 | ms |
| T7 | 1 | - | - | s |

Notes :

1. Please V_{LCD} power on only after connecting interface cable to LCD.
2. Please avoid floating state of interface signal at invalid period.
3. When the interface signal is invalid, be sure to pull down the power supply for LCD V_{LCD} to 0V.
4. LED power must be turn on after power supply for LCD an interface signal are valid.

Product Specification

3-8. V_{LCD} Power dip condition

FIG. 6 Power dip condition

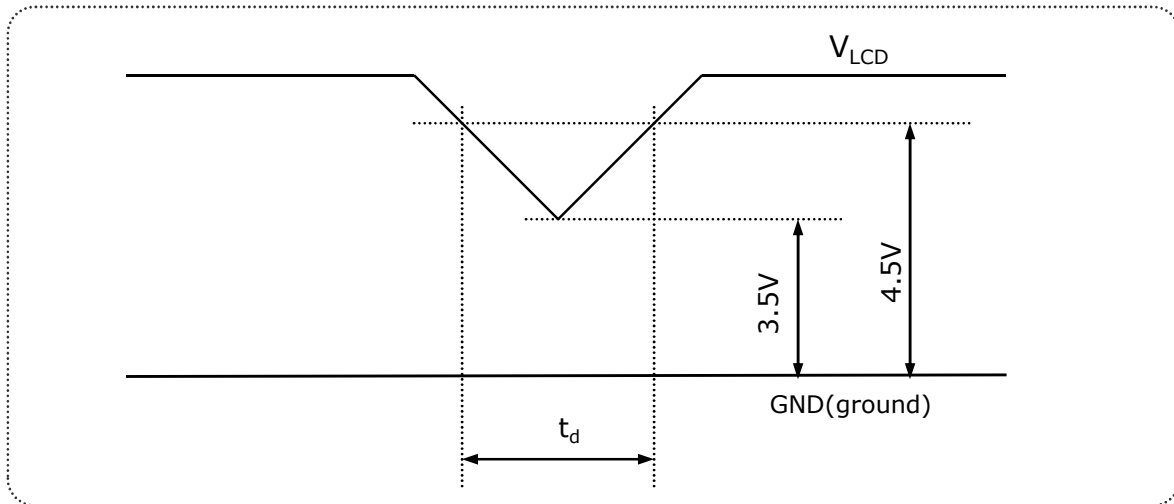

1) Dip condition

$$3.5V \leq V_{LCD} < 4.5V, t_d \leq 20ms$$

2) $V_{LCD} < 3.5V$

V_{LCD} -dip conditions should also follow the Power On/Off conditions for supply voltage.

Product Specification

4. Optical specification

Optical characteristics are determined after the unit has been 'ON' for 30 minutes in a dark environment at 25°C. The values specified are at an approximate distance 50cm from the LCD surface at a viewing angle of Φ and θ equal to 0°.

FIG. 7 presents additional information concerning the measurement equipment and method.

FIG. 7 Optical characteristic measurement equipment and method

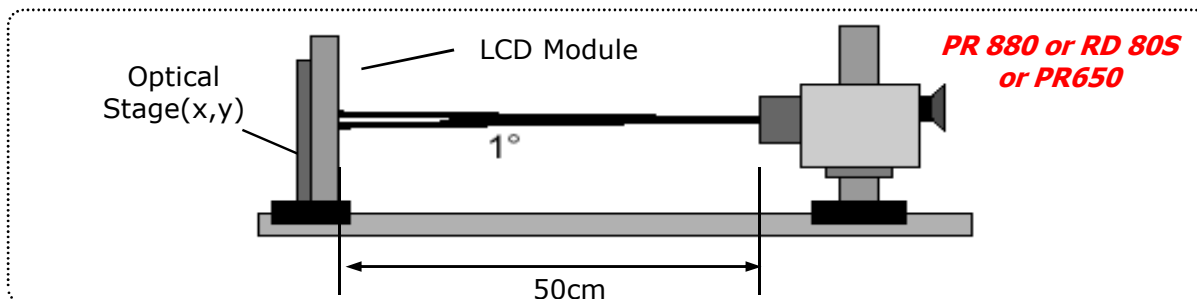

Table 10. Optical characteristics

Ta= 25°C, V_{LCD}=5.0V, fv=60Hz f_{CLK}=108MHz, IBL=60mA

| Parameter | Symbol | Values | | | Units | Notes | |
|-----------------------------|-----------------------------------|-----------------|--------------|-------|-------------------|-------|---|
| | | Min | Typ | Max | | | |
| Contrast Ratio | CR | 700 | 1000 | - | | 1 | |
| Surface Luminance, white | L _{WH} | 200 | 250 | - | cd/m ² | 2 | |
| Luminance Variation | δ_{WHITE} 9P | 75 | | | % | 3 | |
| Response Time | Rise Time | Tr _R | - | 1.3 | 2.6 | ms | 4 |
| | Decay Time | Tr _D | - | 3.7 | 7.4 | ms | |
| Color Coordinates [CIE1931] | RED | Rx | Typ -0.03 | 0.627 | Typ +0.03 | | |
| | | Ry | | 0.347 | | | |
| | GREEN | Gx | | 0.337 | | | |
| | | Gy | | 0.624 | | | |
| | BLUE | Bx | | 0.159 | | | |
| | | By | | 0.046 | | | |
| | WHITE | Wx | | 0.313 | | | |
| Wy | | 0.329 | | | | | |
| Viewing Angle (CR>5) | | | | | | 5 | |
| | x axis, right($\phi=0^\circ$) | θ_r | 75 | 88 | Degree | | |
| | x axis, left ($\phi=180^\circ$) | θ_l | 75 | 88 | | | |
| | y axis, up ($\phi=90^\circ$) | θ_u | 70 | 85 | | | |
| | y axis, down ($\phi=270^\circ$) | θ_d | 70 | 85 | | | |
| Viewing Angle (CR>10) | | | | | | | |
| | x axis, right($\phi=0^\circ$) | θ_r | 70 | 85 | Degree | | |
| | x axis, left ($\phi=180^\circ$) | θ_l | 70 | 85 | | | |
| | y axis, up ($\phi=90^\circ$) | θ_u | 60 | 75 | | | |
| | y axis, down ($\phi=270^\circ$) | θ_d | 70 | 85 | | | |
| Crosstalk | | | | 1.5 | % | 7 | |

Product Specification

Notes :

1. Contrast ratio(CR) is defined mathematically as :It is measured at center point(1)

$$\text{Contrast ratio} = \frac{\text{Surface luminance with all white pixels}}{\text{Surface luminance with all black pixels}}$$

2. Surface luminance is the luminance value at center 1 point(1) across the LCD surface 50cm from the surface with all pixels displaying white. For more information see FIG 8.

3. The variation in surface luminance , δ_{WHITE} is defined as

$$\delta_{\text{WHITE}} = \frac{\text{Minimum (P1,P2P9)}}{\text{Maximum (P1,P2P9)}} * 100$$

For more information see Figure 8.

FIG. 8 Luminance measuring point

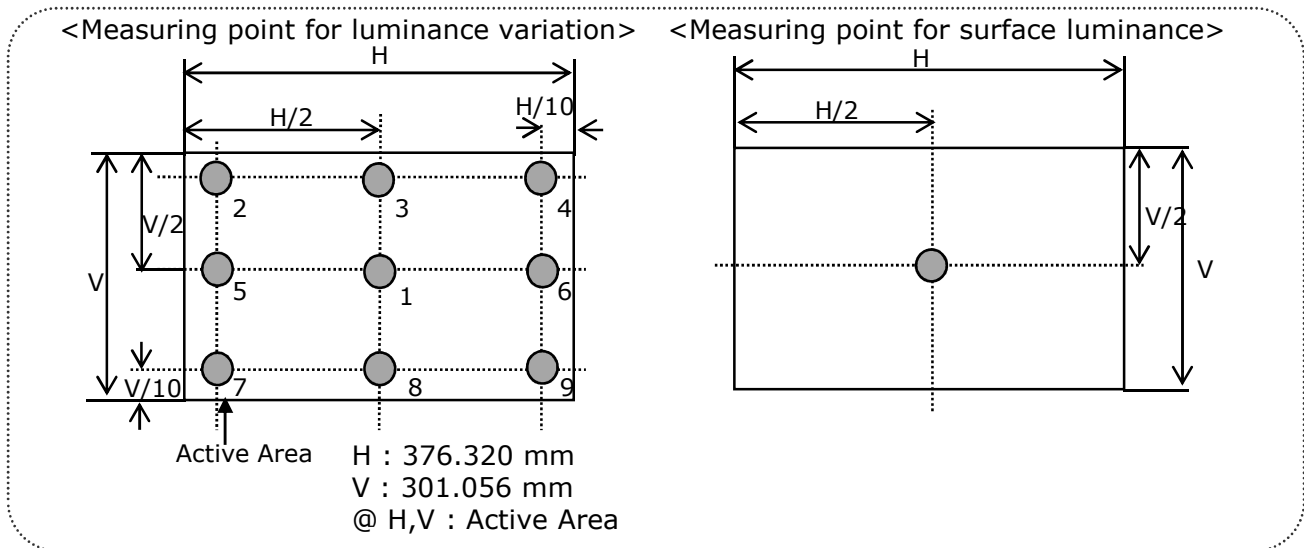

Product Specification

Notes :

4. Response time is the time required for the display to transition from black to white (Decay Time, Tr_D) and from white to black (Rise Time, Tr_R)
The sampling rate is 2,500 sample/sec. For additional information see FIG. 9.

The response time is defined as the following figure and shall be measured by switching the input signal for each gray to gray.

FIG. 9 Response time

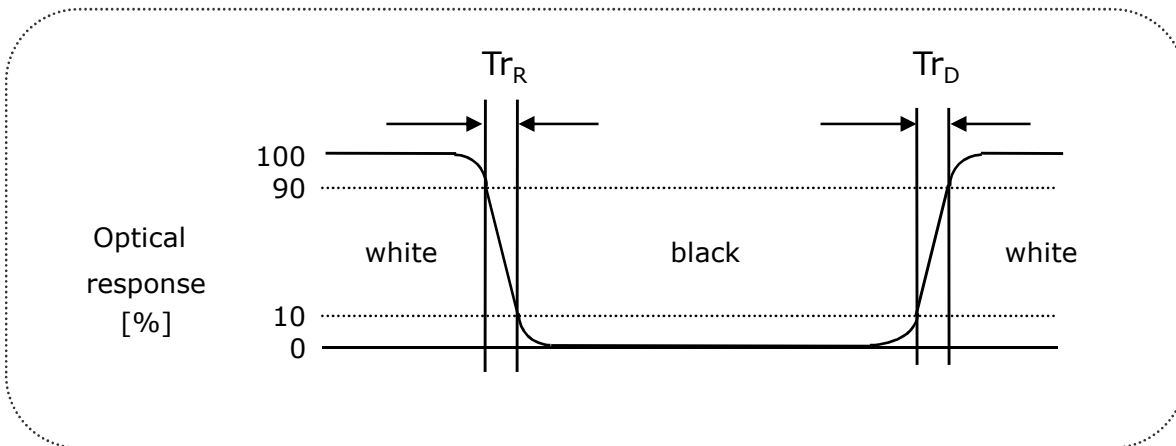

5. Viewing angle is the angle at which the contrast ratio is greater than 10 or 5. The angles are determined for the horizontal or x axis and the vertical or y axis with respect to the z axis which is normal to the LCD surface. For more information see FIG. 10 .

FIG. 10 Viewing angle

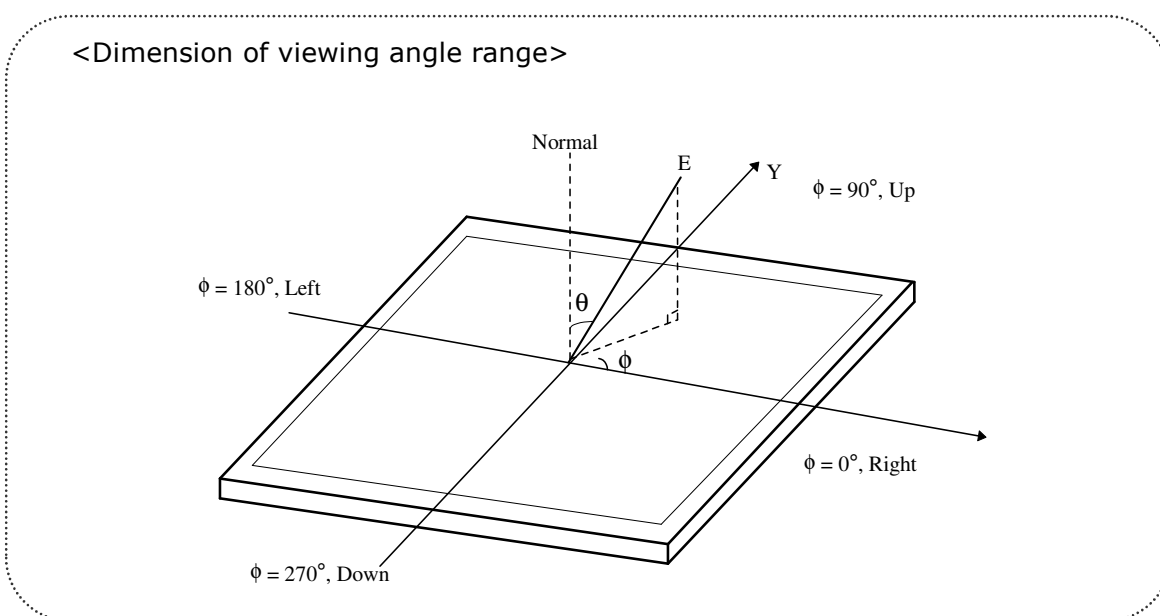

Product Specification

Notes :

6. Gray scale specification

Table 11. Gray scale

| Gray level | Luminance [%] (Typ) |
|------------|---------------------|
| L0 | 0.1 |
| L31 | 0.97 |
| L63 | 4.61 |
| L95 | 11.39 |
| L127 | 21.58 |
| L159 | 35.37 |
| L191 | 52.95 |
| L223 | 74.45 |
| L255 | 100 |

7. Crosstalk

The equation of crosstalk : $(|L_{A[or C]2} - L_{A[or C]1}| / L_{A[or C]1}) \times 100(\%)$ [Vertical],
 $(|L_{B[or D]2} - L_{B[or D]1}| / L_{B[or D]1}) \times 100(\%)$ [Horizontal]

For more information see Figure 11.

FIG. 11 Crosstalk Measuring Point

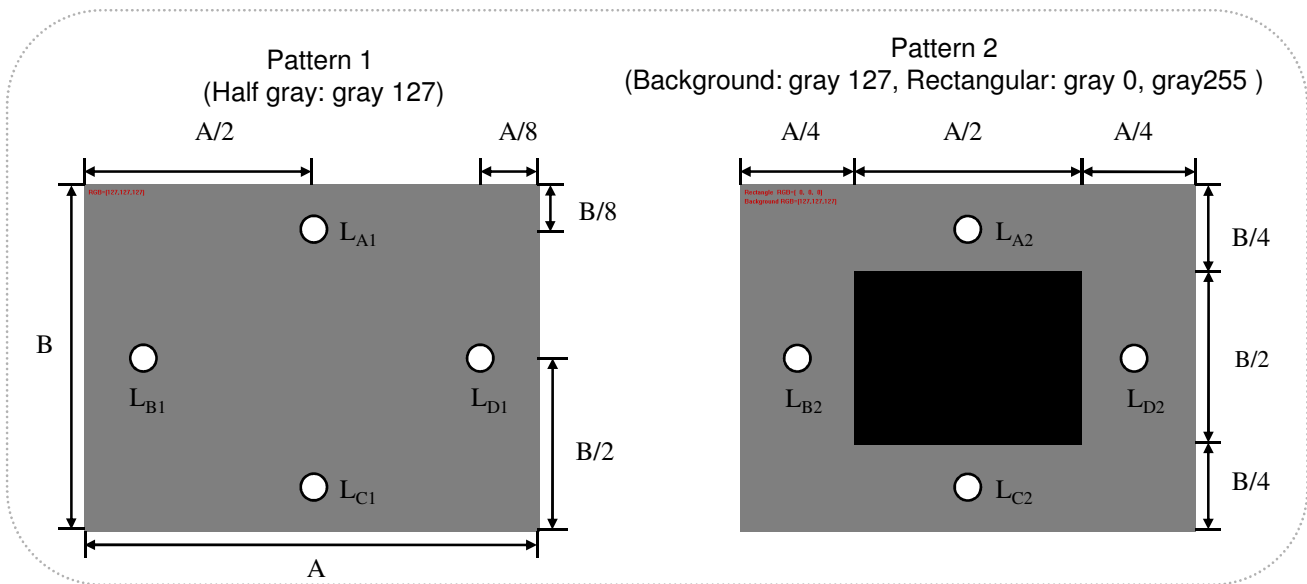

Product Specification
5. Mechanical characteristics

The contents provide general mechanical characteristics. In addition the figures in the next page are detailed mechanical drawing of the LCD.

Table 12. Mechanical characteristics

| | | |
|---------------------|---|------------|
| Outline dimension | Horizontal | 396.0 mm |
| | Vertical | 324.0 mm |
| | Depth | 9.9 mm |
| Bezel area | Horizontal | 380.3 mm |
| | Vertical | 305.0 mm |
| Active display area | Horizontal | 376.320 mm |
| | Vertical | 301.056 mm |
| Weight | 1250g (Typ.) 1350g (Max) | |
| Surface treatment | Hard coating(3H) Anti-glare treatment of the front polarizer | |

Notes : Please refer to a mechanic drawing in terms of tolerance at the next page.

Product Specification

<FRONT VIEW>

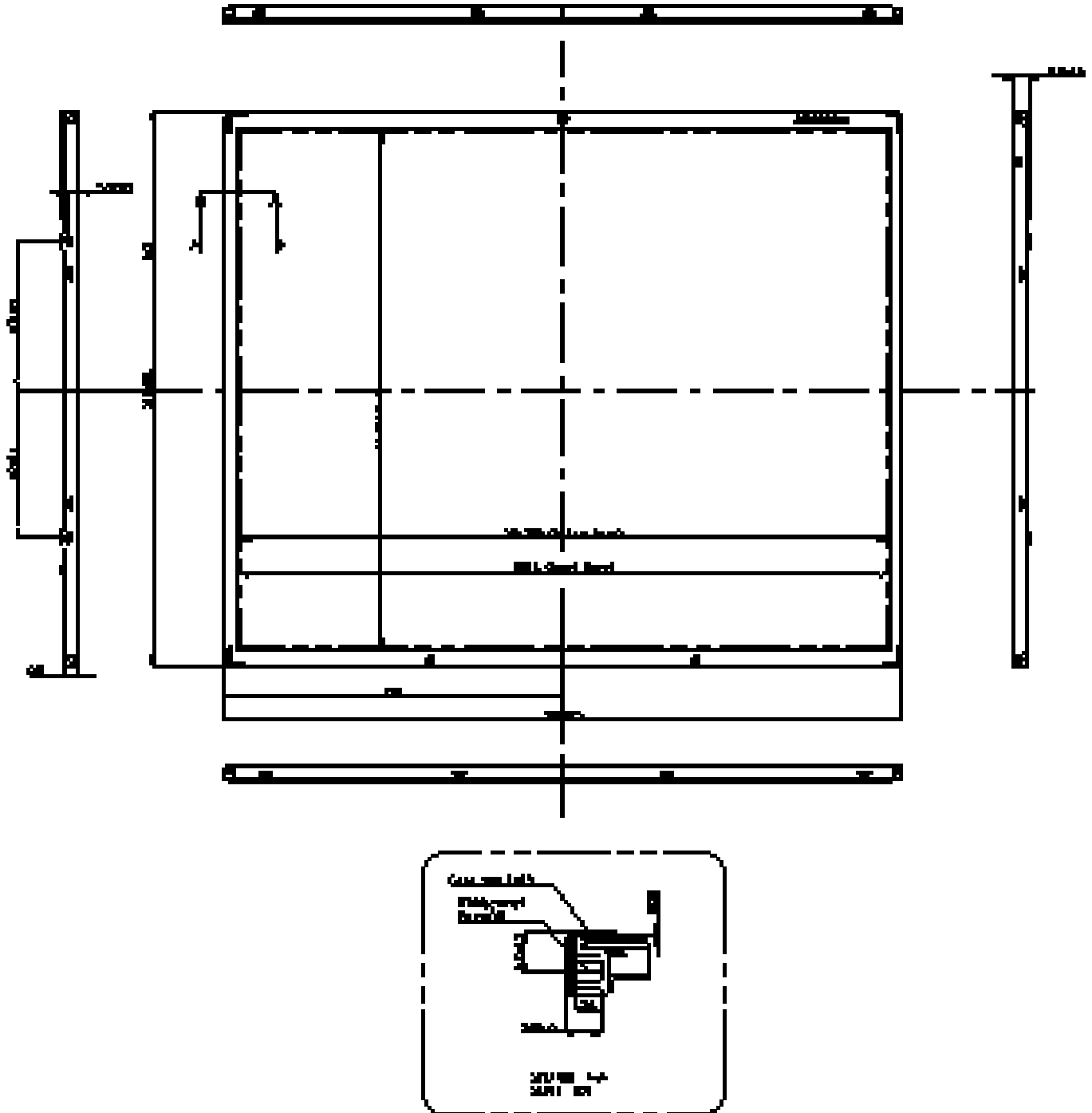

Product Specification

<REAR VIEW>

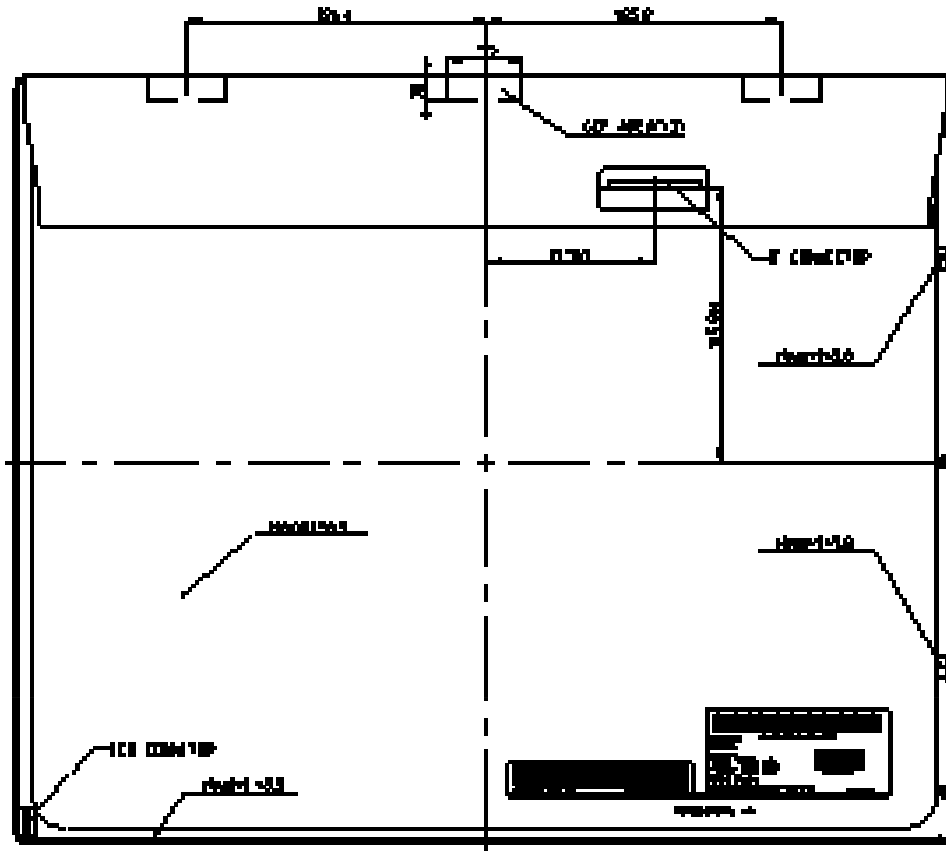

Notes

- 1 Backlight uses 1 LED Pkg. #5271
- 2 I/F Connector Specification
 - MINI-105-115-Female (DIN) or Equivalent
- 3 LCD Connector Specification
 - X09548-4068 (ECC8-03) or Equivalent
- 4 Torque of screw hole : 9.0~15 kgf-cm
- 5 Tap and partial designation for range of display area as following
 - (1) Y-Direction : 1A-B ± 10
 - (2) X-Direction : 1C-D ± 10

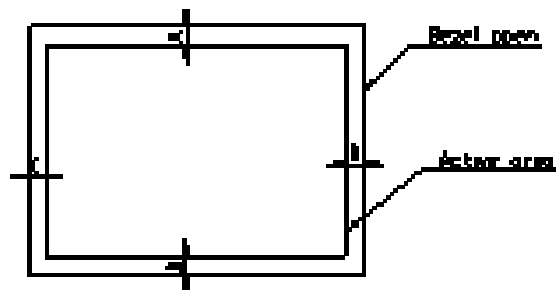

- 6 Unspecified tolerances to be ± 0.1mm
- 7 The D-C area is weak & sensitive, so, please don't press the D-C area

Product Specification
6. Reliability
Table 13. Environment test conditions

| No | Test Item | Condition |
|----|---|--|
| 1 | High temperature storage test | Ta= 60°C 240hrs |
| 2 | Low temperature storage test | Ta= -20°C 240hrs |
| 3 | High temperature operation test | Ta= 50°C 50%RH 240hrs |
| 4 | Low temperature operation test | Ta= 0°C 240hrs |
| 5 | Vibration test (non-operating) | Wave form : random Vibration level : 1.0GRMS Bandwidth : 10-300Hz Duration : X,Y,Z, 20 min One time each direction |
| 6 | Shock test (non-operating) | Shock level : 120G Waveform : half sine wave, 2msec Direction : ±X, ±Y, ±Z One time each direction |
| 7 | Altitude operating storage / shipment | 0 - 10,000 feet(3,048m) 0 - 40,000 feet(12,192m) |

{ Result evaluation criteria }

There should be no change which might affect the practical display function when the display quality test is conducted under normal operating condition.

Product Specification**7. International Standards****7-1. Safety**

- a) UL 60950-1, Second Edition, Underwriters Laboratories Inc.
Information Technology Equipment - Safety - Part 1 : General Requirements.
- b) CAN/CSA C22.2 No.60950-1-07, Second Edition, Canadian Standards Association.
Information Technology Equipment - Safety - Part 1 : General Requirements.
- c) EN 60950-1:2006 + A11:2009, European Committee for Electrotechnical Standardization (CENELEC).
Information Technology Equipment - Safety - Part 1 : General Requirements.
- d) IEC 60950-1:2005, Second Edition, The International Electrotechnical Commission (IEC).
Information Technology Equipment - Safety - Part 1 : General Requirements.
(Including report of IEC60825-1:2001 clause 8 and clause 9)

Notes

- 1. Laser (LED Backlight) Information

| |
|---|
| Class 1M LED Product IEC60825-1 : 2001 Embedded LED Power (Class1M) |
|---|

- 2. Caution

: LED inside.
Class 1M laser (LEDs) radiation when open.
Do not open while operating.

7-2. EMC

- a) ANSI C63.4-2003 "American National Standard for Methods of Measurement of Radio-Noise Emissions from Low-Voltage Electrical and Electronic Equipment in the Range of 9kHz to 40GHz."
American National Standards Institute (ANSI), 2003.
- b) C.I.S.P.R. Pub. 22. Limits and methods of measurement of radio interference characteristics of information technology equipment." International Special Committee on Radio Interference (C.I.S.P.R.), 2005.
- c) EN 55022 "Limits and methods of measurement of radio interference characteristics of information technology equipment." European Committee for Electrotechnical Standardization (CENELEC), 2006.

7-3. Environment

- a) RoHS, Directive 2002/95/EC of the European Parliament and of the council of 27 January 2003

Product Specification

8. Packing

8-1. Designation of lot mark

a) Lot mark

| | | | | | | | | | | | | |
|---|---|---|---|---|---|---|---|---|---|---|---|---|
| A | B | C | D | E | F | G | H | I | J | K | L | M |
|---|---|---|---|---|---|---|---|---|---|---|---|---|

A,B,C : Size (Inch)
 E : Month

D : Year
 F ~ M : Serial No.

Note:

1. Year

| | | | | | | | | | | |
|------|------|------|------|------|------|------|------|------|------|------|
| Year | 2011 | 2012 | 2013 | 2014 | 2015 | 2016 | 2017 | 2018 | 2019 | 2020 |
| Mark | A | B | C | D | E | F | G | H | J | K |

2. Month

| | | | | | | | | | | | | |
|-------|-----|-----|-----|-----|-----|-----|-----|-----|-----|-----|-----|-----|
| Month | Jan | Feb | Mar | Apr | May | Jun | Jul | Aug | Sep | Oct | Nov | Dec |
| Mark | 1 | 2 | 3 | 4 | 5 | 6 | 7 | 8 | 9 | A | B | C |

b) Location of lot mark

Serial No. is printed on the label. The label is attached to the backside of the LCD module. This is subject to change without prior notice.

8-2. Packing form

a) Package quantity in one box : 11 pcs

b) Box size : 418(L)*365(W)*492(H)

Product Specification**9. Precautions**

Please pay attention to the followings when you use this TFT LCD module.

9-1. Mounting Precautions

- (1) You must mount a module using holes arranged in four corners or four sides.
- (2) You should consider the mounting structure so that uneven force (ex. Twisted stress) is not applied to the Module. And the case on which a module is mounted should have sufficient strength so that external force is not transmitted directly to the module.
- (3) Please attach the surface transparent protective plate to the surface in order to protect the polarizer. Transparent protective plate should have sufficient strength in order to the resist external force.
- (4) You should adopt radiation structure to satisfy the temperature specification.
- (5) Acetic acid type and chlorine type materials for the cover case are not desirable because the former generates corrosive gas of attacking the polarizer at high temperature and the latter causes circuit break by electro-chemical reaction.
- (6) Do not touch, push or rub the exposed polarizers with glass, tweezers or anything harder than HB pencil lead. And please do not rub with dust clothes with chemical treatment. Do not touch the surface of polarizer for bare hand or greasy cloth.
(Some cosmetics are detrimental to the polarizer.)
- (7) When the surface becomes dusty, please wipe gently with absorbent cotton or other soft materials like chamois soaks with petroleum benzene. Normal-hexane is recommended for cleaning the adhesives used to attach front / rear polarizers. Do not use acetone, toluene and alcohol because they cause chemical damage to the polarizer.
- (8) Wipe off saliva or water drops as soon as possible. Their long time contact with polarizer causes deformations and color fading.
- (9) Do not open the case because inside circuits do not have sufficient strength.

9-2. Operating precautions

- (1) The spike noise causes the mis-operation of circuits. It should be lower than following voltage : $V = \pm 200\text{mV}$ (Over and under shoot voltage)
- (2) Response time depends on the temperature. (In lower temperature, it becomes longer.)
- (3) Brightness depends on the temperature. (In lower temperature, it becomes lower.)
And in lower temperature, response time (required time that brightness is stable after turned on) becomes longer.
- (4) Be careful for condensation at sudden temperature change. Condensation makes damage to polarizer or electrical contacted parts. And after fading condensation, smear or spot will occur.
- (5) When fixed patterns are displayed for a long time, remnant image is likely to occur.
- (6) Module has high frequency circuits. Sufficient suppression to the electromagnetic interference shall be done by system manufacturers. Grounding and shielding methods may be important to minimized the interference.
- (7) Please do not give any mechanical and/or acoustical impact to LCM. Otherwise, LCM can not be operated its full characteristics perfectly.
- (8) A screw which is fastened up the steels should be a machine screw (if not, it causes metal foreign material and deal LCM a fatal blow)
- (9) Please do not set LCD on its edge.

Product Specification**9-3. Electrostatic discharge control**

Since a module is composed of electronic circuits, it is not strong to electrostatic discharge. Make certain that treatment persons are connected to ground through wrist band etc. And don't touch interface pin directly.

9-4. Precautions for strong light exposure

Strong light exposure causes degradation of polarizer and color filter.

9-5. Storage

When storing modules as spares for a long time, the following precautions are necessary.

- (1) Store them in a dark place. Do not expose the module to sunlight or fluorescent light. Keep the temperature between 5°C and 35°C at normal humidity.
- (2) The polarizer surface should not come in contact with any other object.
It is recommended that they be stored in the container in which they were shipped.

9-6. Handling precautions for protection film

- (1) The protection film is attached to the bezel with a small masking tape.
When the protection film is peeled off, static electricity is generated between the film and polarizer. This should be peeled off slowly and carefully by people who are electrically grounded and with well ion-blown equipment or in such a condition, etc.
- (2) When the module with protection film attached is stored for a long time, sometimes there remains a very small amount of glue still on the bezel after the protection film is peeled off.
- (3) You can remove the glue easily. When the glue remains on the bezel surface or its vestige is recognized, please wipe them off with absorbent cotton waste or other soft material like chamois soaked with normal-hexane.