

## ***TFT-Display Datenblatt***

Modell LB121S03-TL05

### **Kurzdaten**

Hersteller	LG Display
Diagonale	12,1" / 30,7 cm
Format	4:3
Auflösung	800x600
Backlight	LED / 450 cd/m <sup>2</sup>
Interface	LVDS
Touchscreen	nein
Temperatur	-20...+70 °C (Betrieb)

# SPECIFICATION FOR APPROVAL

- ( ◆ ) Preliminary Specification
- (   ) Final Specification

Title	12.1" SVGA TFT LCD
-------	--------------------

Customer	
MODEL	

SUPPLIER	LG Display Co., Ltd.
*MODEL	LB121S03
Suffix	TL05

\*When you obtain standard approval,  
please use the above model name without suffix

APPROVED BY	SIGNATURE
/	_____
/	_____
/	_____

Please return 1 copy for your confirmation with your signature and comments.

APPROVED BY	SIGNATURE
Y. T. Woo / G.Manager	_____
<b>REVIEWED BY</b>	
K. H. Choi / Manager [C]	_____
K. H. Moon / Manager [M]	_____
M. S. Kang / Manager [P]	_____
<b>PREPARED BY</b>	
B. C. Lee / Senior Engineer	_____

**IT/Mobile Development Divison1.**  
**LG Display Co.,**

## Contents

No	ITEM	Page
	COVER	1
	CONTENTS	2
	RECORD OF REVISIONS	3
1	GENERAL DESCRIPTION	4
2	ABSOLUTE MAXIMUM RATINGS	5
3	ELECTRICAL SPECIFICATIONS	6
3-1	ELECTRICAL CHARACTREISTICS	6
3-2	INTERFACE CONNECTIONS	7
3-3	CONNECTION BETWEEN HOST SYSTEM AND LCD MODULE	8
3-4	LVDS SIGNAL TIMING SPECIFICATIONS	11
3-5	SIGNAL TIMING SPECIFICATION	13
3-6	Display Color and Input Signal	14
3-7	POWER SEQUENCE	17
4	OPTICAL SFECIFICATIONS	19
5	MECHANICAL CHARACTERISTICS	23
6	RELIABLITY	26
7	INTERNATIONAL STANDARDS	27
7-1	SAFETY	27
7-2	Environmental	27
7-3	EMC	27
8	PACKING	28
8-1	DESIGNATION OF LOT MARK	28
8-2	PACKING FORM	28
9	PRECAUTIONS	29



## 1. General Description

The LB121S03-TL05 is a Color Active Matrix Liquid Crystal Display with an integral LED backlight system. The matrix employs a-Si Thin Film Transistor as the active element. It is a transmissive type display operating in the normally white mode. This TFT-LCD has 12.1 inches diagonally measured active display area with SVGA resolution (800 horizontal by 600 vertical pixel array). Each pixel is divided into Red, Green and Blue sub-pixels or dots which are arranged in vertical stripes. Gray scale or the brightness of the sub-pixel color is determined with a 8-bit (or 6-bit) gray scale signal for each dot, thus, presenting a palette of more than 16,777,216 (or 262,144) colors.

The LB121S03-TL05 has been designed to apply the interface method that enables low power, high speed, low EMI.

The LB121S03-TL05 is intended to support applications where thin thickness, low power are critical factors and graphic displays are important. In combination with the vertical arrangement of the sub-pixels, the LB121S03-TL05 characteristics provide an excellent flat display for office automation products such as PC or etc.

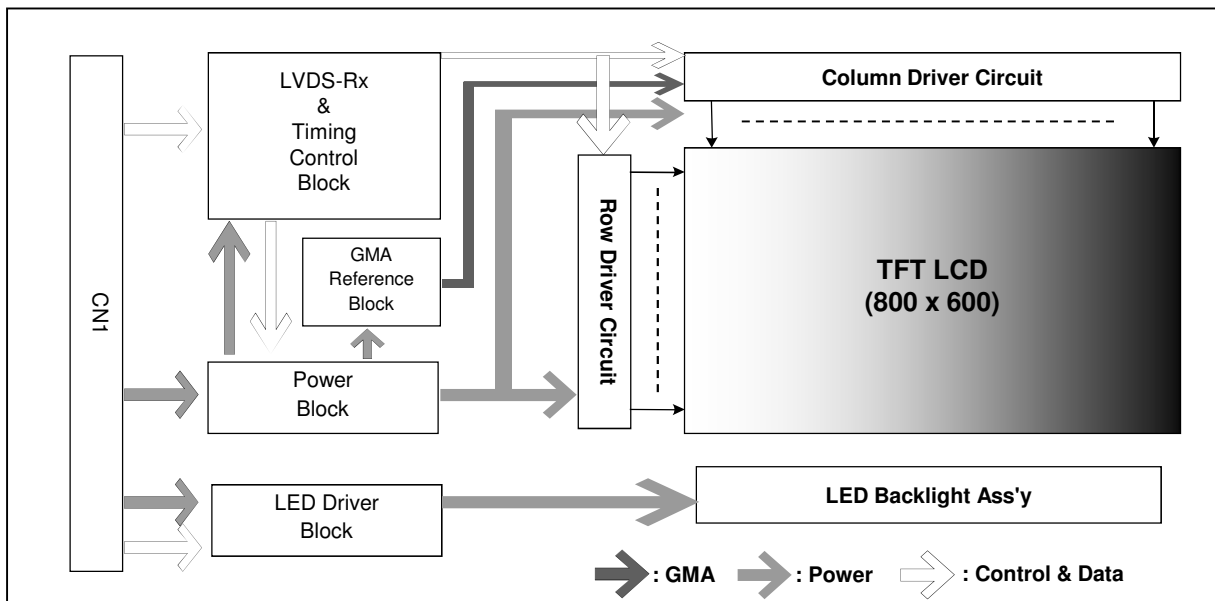

## General Features

Active Screen Size	12.1 inches(30.75cm) diagonal
Outline Dimension	276(H) × 209(V) × 9(D) mm (Typ.)
Pixel Pitch	0.3075 mm × 0.3075 mm
Pixel Format	800 horiz. By 600 vert. Pixels RGB strip arrangement
Color Depth	16,777,216 colors (A-FRC) @ 8-bit input 262,144 colors @ 6-bit input
Luminance, White	450 cd/m <sup>2</sup> (Typ.)
Power Consumption	Total 6.81 Watt(Typ.) @ LCM circuit 0.69 Watt(Typ.), B/L input TBD Watt(Typ.)
Weight	515g (Typ) 530g(Max)
Display Operating Mode	Transmissive mode, normally white
Surface Treatment	Anti-glare
RoHS Comply	Yes

## 2. Absolute Maximum Ratings

The following are maximum values which, if exceeded, may cause faulty operation or damage to the unit.

**Table 1. ABSOLUTE MAXIMUM RATINGS**

Parameter		Symbol	Values		Units	Notes
			Min	Max		
Power Input Voltage	LCD circuit	VCC	-0.3	3.6	Vdc	at 25 ± 5°C
	LED circuit	V <sub>LED</sub>	-0.3	12.6	Vdc	
Driver Control Voltage	LCD circuit	V <sub>BIT_SEL</sub>	-0.3	3.6	Vdc	
	LED circuit	V <sub>PWM</sub>	-0.3	5	Vdc	
		V <sub>LED_EN</sub>	-0.3	12.6	Vdc	
Operating Temperature		T <sub>OP</sub>	-20	70	°C	
Storage Temperature		T <sub>ST</sub>	-30	80	°C	1
Operating Ambient Humidity		H <sub>OP</sub>	10	90	%RH	1
Storage Humidity		H <sub>ST</sub>	10	90	%RH	1

Note : 1. Temperature and relative humidity range are shown in the figure below.  
 Wet bulb temperature should be 44°C Max, and no condensation of water.

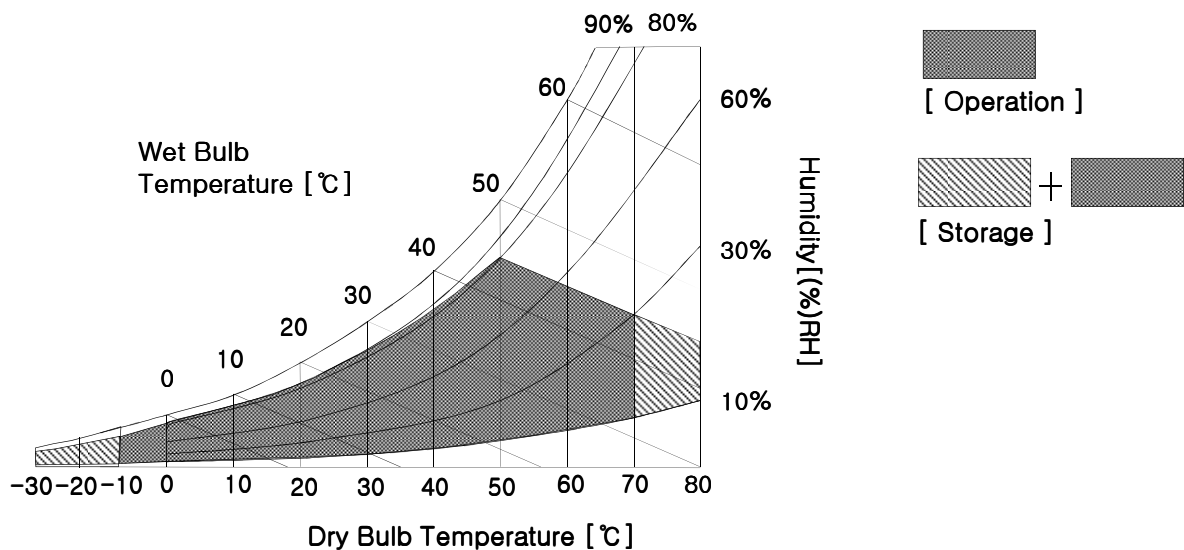

## Product Specification

**3. Electrical Specifications**
**3-1. Electrical Characteristics**

The LB121S03-TL05 requires two power inputs. One is employed to power the LCD electronics and to drive the TFT array and liquid crystal. The second input which powers the LED Backlight.

**Table 2. ELECTRICAL CHARACTERISTICS**

Parameter	Symbol	Values			Unit	Notes
		Min	Typ	Max		
MODULE :						
Power Supply Input Voltage	VCC	3.0	3.3	3.6	V <sub>DC</sub>	
Power Supply Input Current	I <sub>CC</sub>	-	230	270	mA	1
Power Consumption	P <sub>c</sub>	-	0.69	0.89	Watt	1
LED Backlight ( With LED Driver ) :						
LED Power Input Voltage	V <sub>LED</sub>	10.8	12	12.6	V	2
LED Power Input Current	I <sub>LED</sub>	-	TBD		A	3
LED Power Consumption	P <sub>LED</sub>	-	TBD		Watt	3
PWM Duty Ratio		10		100	%	4
PWM Frequency	F <sub>PWM</sub>	-	1	-	KHz	5
PWM High Level Voltage	V <sub>PWM_H</sub>	3	3.3	5	V	
PWM Low Level Voltage	V <sub>PWM_L</sub>	0		0.5	V	
LED_EN High Voltage	V <sub>LED_EN_H</sub>	3	3.3	V <sub>LED</sub>	V	
LED_EN Low Voltage	V <sub>LED_EN_L</sub>	0		0.5	V	
Life Time		50,000	-	-	Hrs	6

Note)

- The specified current and power consumption are under the V<sub>cc</sub> = 3.3V , 25°C, f<sub>v</sub> = 60Hz condition whereas Mosaic pattern(8x6) is displayed and f<sub>v</sub> is the frame frequency.

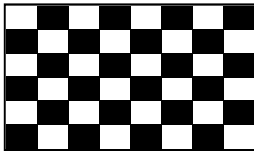

- The measuring position is the connector of LCM and the test conditions are under 25°C.
- The current and power consumption with LED Driver are under the V<sub>LED</sub> = 12.0V , 25°C, Dimming of max luminance whereas white pattern is displayed.
- The operation of LED Driver below minimum dimming ratio may cause flickering or reliability issue.
- This Spec. is not effective at 100% dimming ratio as an exception because it has DC level equivalent to 0Hz. In spite of acceptable range as defined, the PWM frequency should be fixed and stable for more consistent brightness control at any specific level desired.
- The life time is determined as the time at which brightness of LED is 50% compare to that of initial value at the typical LED current.

## Product Specification

**3-2. Interface Connections**

The electronics interface connector is a model IS100-L30R-C23 manufactured by UJU.

**Table 3. MODULE CONNECTOR PIN CONFIGURATION (CN1)**

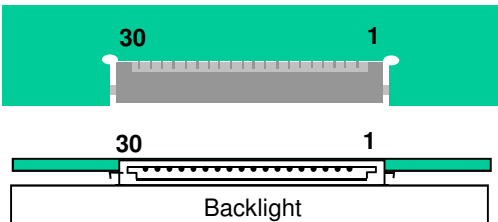
Pin	Symbol	Description	Notes
1	VCC	Power Supply for module, 3.3V Typ.	1, Interface chips 1.1 LCD : THine, KE5M6U2730WFP(LCD Controller) including LVDS Receiver 1.2 System : THC63LVDM83R or Equivalent  2, Connector 2.1 LCD : IS100-L30R-C23, UJU or Equivalent 2.2 Mating : FI-X30H and FI-X30HL (Manufactured by JAE) or Equivalent  <div style="text-align: center;"> <b>Rear view of LCM</b>   </div>
2	VCC	Power Supply for module, 3.3V Typ.	
3	GND	Ground	
4	Bit_SEL	Bit Selection, High(3.3V)/NC : 8 Bit, Low : 6 Bit	
5	A1M	Negative LVDS differential data input	
6	A1P	Positive LVDS differential data input	
7	GND	Ground	
8	A2M	Negative LVDS differential data input	
9	A2P	Positive LVDS differential data input	
10	GND	Ground	
11	A3M	Negative LVDS differential data input	
12	A3P	Positive LVDS differential data input	
13	GND	Ground	
14	CLKM	Negative LVDS differential clock input	
15	CLKP	Positive LVDS differential clock input	
16	GND	GND	
17	A4M	Negative LVDS differential data input(for 8 bit)	
18	A4P	Positive LVDS differential data input(for 8 bit)	
19	NC	Used only LGD internal test. Please treat it as NC.	
20	NC	Used only LGD internal test. Please treat it as NC.	
21	GND	Ground	
22	GND	Ground	
23	GND	Ground	
24	GND	Ground	
25	PWM	System PWM input for dimming control	
26	LED_EN	High(Typ.3.3V): Backlight On, Low(0V): Backlight Off	
27	GND	GND	
28	VLED	Power Supply, 12V Typ.	
29	VLED	Power Supply, 12V Typ.	
30	VLED	Power Supply, 12V Typ.	

- Notes : 1. All GND(ground) pins should be connected together and the LCD's metal frame.  
 2. All  $V_{CC}$ (power input) pins should be connected together.



Product Specification

3-3. Connection between Host system and LVDS receiver

Connection between Host system and LVDS receiver should be different by input signal condition(8bit or 6bit). Please refer to 3.3.1 and 3.3.2.

3.3.1 Input data signal : 8bit

If input data is 8bit, connect MSB 2bit of R,G,B to TD0~TD5 pin of LVDS Tx. Refer to FIG 1 and Table 5 for more detail.

Fig 1. REQUIRED SIGNAL ASSIGNMENT FOR LVDS TRANSMITTER(THC63LVDM83R) – 8Bit

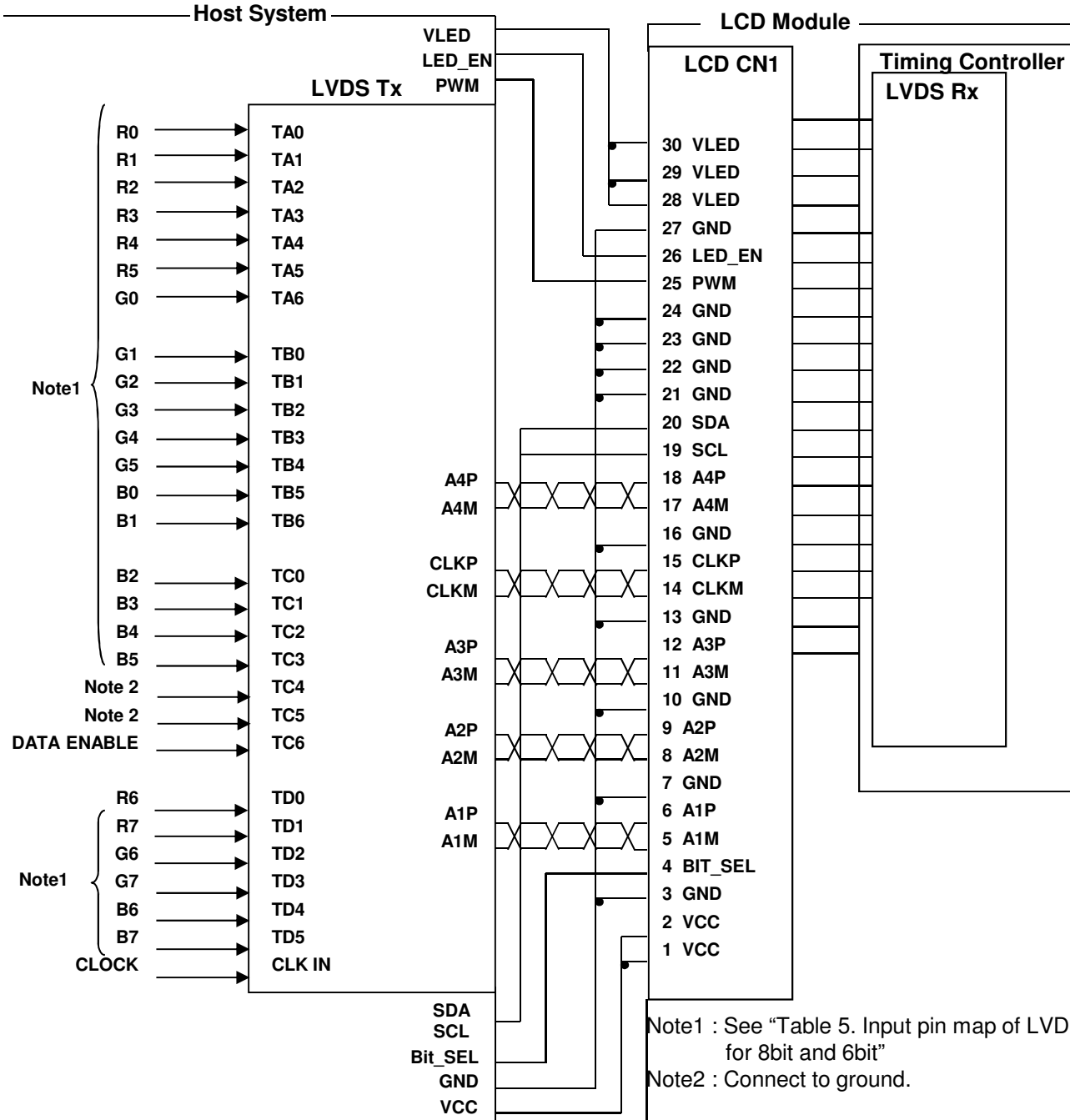

Product Specification

3.3.2 Input data signal : 6bit

If input data is 6bit, pin map of host system should be different with 8bit. Refer to FIG 2 and Table 5 for more detail.

Fig 2. REQUIRED SIGNAL ASSIGNMENT FOR LVDS TRANSMITTER(THC63LVDM83R) – 6Bit

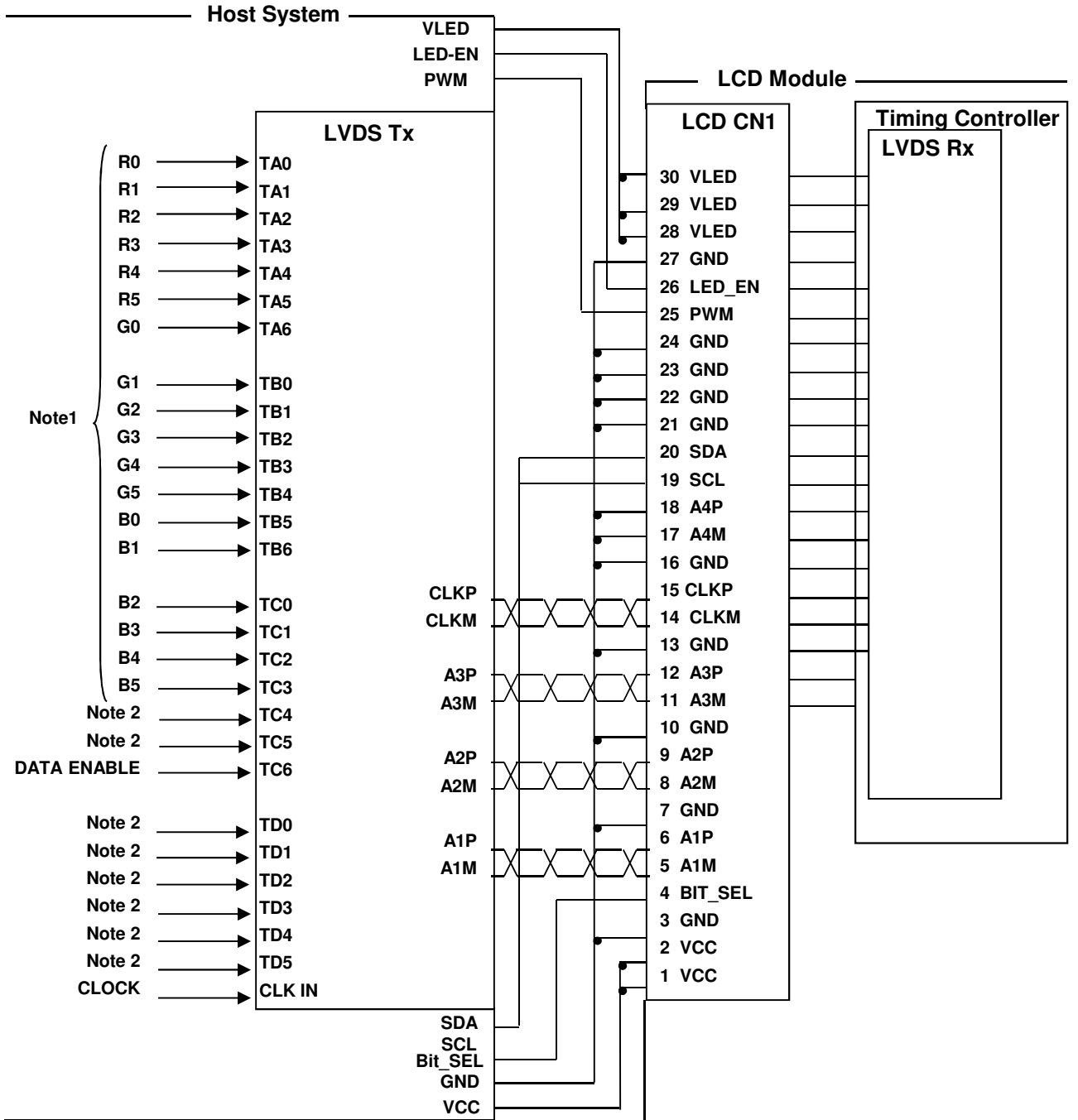

Note1 : R0(6bit) is not equal to R0(8bit). See "Table 5. Input pin map of LVDS Tx for 8bit and 6bit" for more detail.  
Note2 : Connect to ground.

## Product Specification

**Table 5. Input pin map of LVDS Tx for 8bit and 6bit**

TTL Data		LVDS Tx input Pin (Pin #)	TTL Data		LVDS Tx input Pin (Pin #)	Note
8bit			6Bit			
LSB	R0	TA0 (51)		-	-	If input data is 6bit, don't connect LSB two data to LVDS Tx.
	R1	TA1 (52)		-	-	
	R2	TA2 (54)	LSB	R0	TA0 (51)	TTL R2(8bit)=TTL R0(6bit)
	R3	TA3 (55)		R1	TA1 (52)	TTL R3(8bit)=TTL R1(6bit)
	R4	TA4 (56)		R2	TA2 (54)	TTL R4(8bit)=TTL R2(6bit)
	R5	TA5 (3)		R3	TA3 (55)	TTL R5(8bit)=TTL R3(6bit)
	R6	TD0 (50)		R4	TA4 (56)	TTL R6(8bit)=TTL R4(6bit)
MSB	R7	TD1 (2)	MSB	R5	TA5 (3)	TTL R7(8bit)=TTL R5(6bit)
LSB	G0	TA6 (4)		-	-	If input data is 6bit, don't connect LSB two data to LVDS Tx.
	G1	TB0 (6)		-	-	
	G2	TB1 (7)	LSB	G0	TA6 (4)	TTL G2(8bit)=TTL G0(6bit)
	G3	TB2 (11)		G1	TB0 (6)	TTL G3(8bit)=TTL G1(6bit)
	G4	TB3 (12)		G2	TB1 (7)	TTL G4(8bit)=TTL G2(6bit)
	G5	TB4 (14)		G3	TB2 (11)	TTL G5(8bit)=TTL G3(6bit)
	G6	TD2 (8)		G4	TB3 (12)	TTL G6(8bit)=TTL G4(6bit)
MSB	G7	TD3 (10)	MSB	G5	TB4 (14)	TTL G7(8bit)=TTL G5(6bit)
LSB	B0	TB5 (15)		-	-	If input data is 6bit, don't connect LSB two data to LVDS Tx.
	B1	TB6 (19)		-	-	
	B2	TC0 (20)	LSB	B0	TB5 (15)	TTL B2(8bit)=TTL B0(6bit)
	B3	TC1 (22)		B1	TB6 (19)	TTL B3(8bit)=TTL B1(6bit)
	B4	TC2 (23)		B2	TC0 (20)	TTL B4(8bit)=TTL B2(6bit)
	B5	TC3 (24)		B3	TC1 (22)	TTL B5(8bit)=TTL B3(6bit)
	B6	TD4 (16)		B4	TC2 (23)	TTL B6(8bit)=TTL B4(6bit)
MSB	B7	TD5 (18)	MSB	B5	TC3 (24)	TTL B7(8bit)=TTL B5(6bit)
Data Enable		TC6 (30)	Data Enable		TC6 (30)	
CLOCK		CLKIN (31)	CLOCK		CLKIN (31)	

Note : LVDS Tx - THC63LVDM83R(Thine) or equivalent.

## Product Specification

**3-4. LVDS Signal Timing Specifications**
**3-4.1. DC specification**

Description	Symbol	Min	Max	Unit	Notes
LVDS Differential Voltage	$ V_{ID} $	100	600	mV	-
LVDS Common mode Voltage	$V_{CM}$	0.6	1.8	V	-
LVDS Input Voltage Range	$V_{IN}$	0.3	2.1	V	-

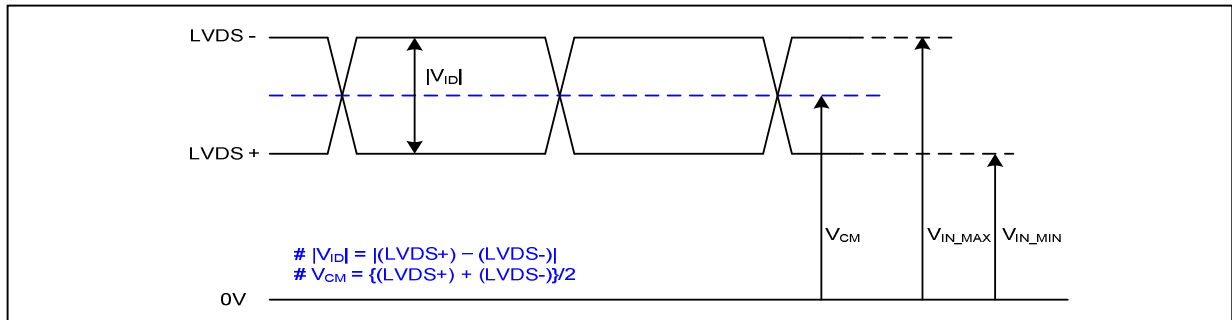
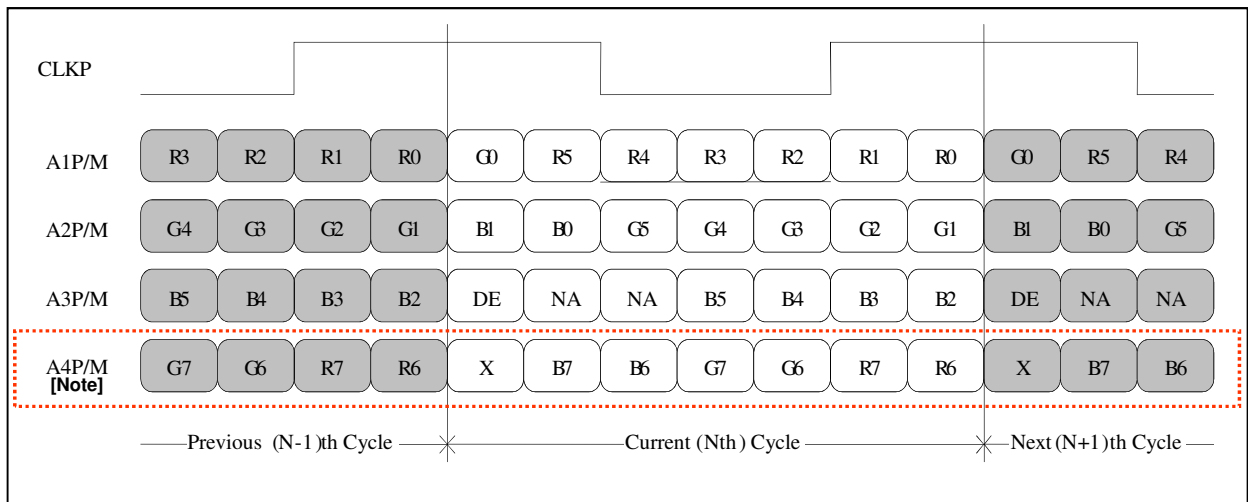

**3-4.2. Data format**

Note : When input condition of 'Bit SEL' is low for 6bit operation(262,144 colors), A4 P/M is excluded among the pairs

## Product Specification

**3-4.3. AC specification**

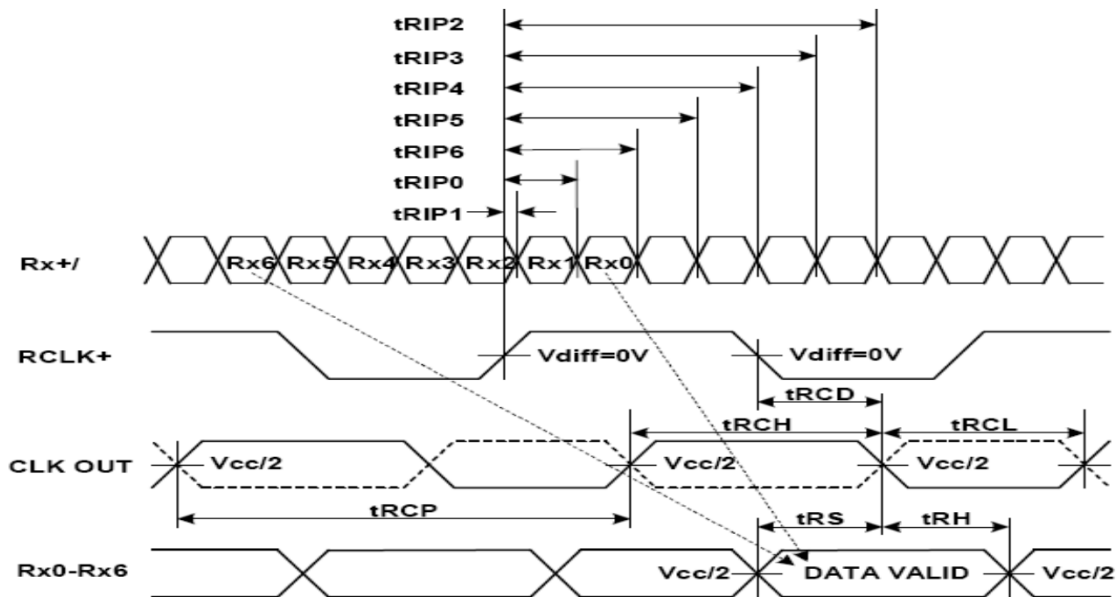
Symbol	Parameter	Min	Typ	Max	Unit
tCLK	LVDS CLK Period	25	25.9	27	ns
tRCH	CLK OUT High Time	-	4T/7	-	ns
tRCL	CLK OUT Low Time	-	3T/7	-	ns
tRS	Data Setup to CLK OUT	3T/7-2.5			ns
TRH	Data Hold from CLK OUT	4T/7-3.5	-	-	ns
tRIP1	Input Data Position 0	-0.4	0.0	0.4	ns
tRIP0	Input Data Position 1	T/7-0.4	T/7	T/7+0.4	ns
tRIP6	Input Data Position 2	2T/7-0.4	2T/7	2T/7+0.4	ns
tRIP5	Input Data Position 3	3T/7-0.4	3T/7	3T/7+0.4	ns
tRIP4	Input Data Position 4	4T/7-0.4	4T/7	4T/7+0.4	ns
tRIP3	Input Data Position 5	5T/7-0.4	5T/7	5T/7+0.4	ns
tRIP2	Input Data Position 6	6T/7-0.4	6T/7	6T/7+0.4	ns



&lt; AC Timing Diagram &gt;

## Product Specification

**3-5. Signal Timing Specification**

This is the signal timing required at the input of the CNT1. All of the interface signal timing should be satisfied with the following specifications and specifications of LVDS Tx/Rx for its proper operation.

**Table 6. Timing Table**

ITEM	Symbol		Min	Typ	Max	Unit	Note
DCLK	Frequency	fCLK	37.0	38.5	40.0	MHz	
Hsync	Period	tHP	990	1024	1100	tCLK	
	Width	tWH	12	64	120		
Vsync	Period	tVP	606	625	730	tHP	
	Width	tWV	1	6	24		
Data Enable	Horizontal back porch	tHBP	32	88	120	tCLK	
	Horizontal front porch	tHFP	32	72	80		
	Horizontal Active	tWHA	800	800	800		
	Vertical back porch	tVBP	2	15	22	tHP	
	Vertical front porch	tVFP	3	4	5		
	Vertical Active	tWVA	600	600	600		

**Notes**

- DE Only mode operation.
- tHFP, tWH and tHBP should be any times of a character number (8).  $tHFP+tWH+tHBP < (1/2)tWHA$
- No variation of the total number of Hsync and DE in a frame is required for normal operation.
- No variation of the total number of clock in a Hsync period for tVBP is required for normal operation.

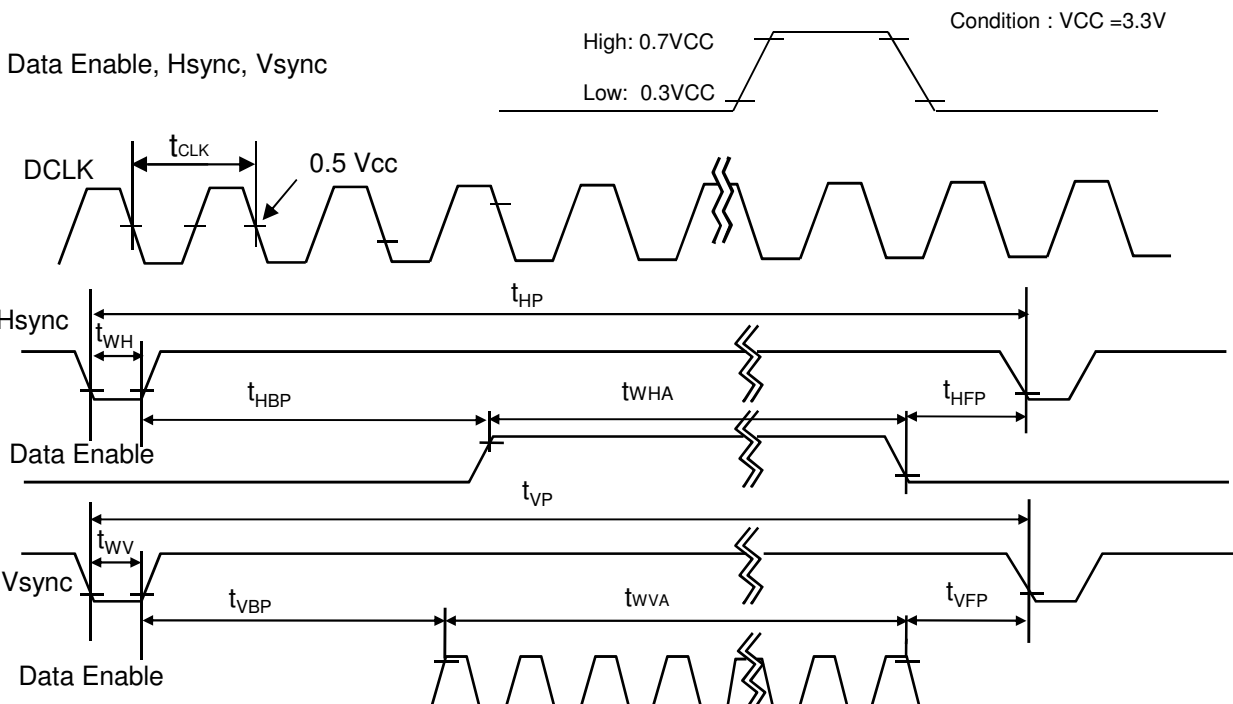

### 3-6. Display Color and Input Signals

#### 3-6-1. Input Condition of Bit\_SEL signal and data signals

LB121S03-TL05 can display 16,777,216 color in 256 gray scales and 262,144 colors in 64 gray scales by input condition of Bit\_SEL signal and data signals. See following table.

**Table 7. FRC and Input data signal**

Input data signals	Bit_SEL	Input signal for Pin 1 of CN1	Input signal for Pin 2 of CN1	Display color	Notes
8-bit	High/NC	A4P	A4M	16,777,216	1,3
6-bit	Low	GND	GND	262,144	2,4

Note 1 : See “3-6-2.Color Input Data Reference(16,777,216)”

Note 2 : See “3-6-3. Color Input Data Reference(262,144)”

Note 3 : See “3-3-1. Input data signal : 8bit”

Note 4 : See “3-3-2. Input data signal : 6bit”

## Product Specification

**3-6-2. Color Input Data Reference(16,777,216 color)**

The brightness of each primary color (red, green and blue) is based on the 8-bit gray scale data input for the color ; the higher the binary input, the brighter the color. The table below provides a reference for color versus data input. Please see “3-6-1. Input Condition of FRC signal and data signals” for 16,777,216 color.

**Table 8-1. COLOR DATA REFERENCE**

Color		Input Color Data																							
		RED								GREEN								BLUE							
		MSB				LSB				MSB				LSB				MSB				LSB			
		R7	R6	R5	R4	R3	R2	R1	R0	G7	G6	G5	G4	G3	G2	G1	G0	B7	B6	B5	B4	B3	B2	B1	B0
Basic Color	Black	0	0	0	0	0	0	0	0	0	0	0	0	0	0	0	0	0	0	0	0	0	0	0	0
	Red	1	1	1	1	1	1	1	1	0	0	0	0	0	0	0	0	0	0	0	0	0	0	0	0
	Green	0	0	0	0	0	0	0	0	1	1	1	1	1	1	1	1	0	0	0	0	0	0	0	0
	Blue	0	0	0	0	0	0	0	0	0	0	0	0	0	0	0	0	1	1	1	1	1	1	1	1
	Cyan	0	0	0	0	0	0	0	0	1	1	1	1	1	1	1	1	1	1	1	1	1	1	1	1
	Magenta	1	1	1	1	1	1	1	1	0	0	0	0	0	0	0	0	1	1	1	1	1	1	1	1
	Yellow	1	1	1	1	1	1	1	1	1	1	1	1	1	1	1	1	0	0	0	0	0	0	0	0
	White	1	1	1	1	1	1	1	1	1	1	1	1	1	1	1	1	1	1	1	1	1	1	1	1
RED	RED (000)	0	0	0	0	0	0	0	0	0	0	0	0	0	0	0	0	0	0	0	0	0	0	0	0
	RED (001)	0	0	0	0	0	0	0	1	0	0	0	0	0	0	0	0	0	0	0	0	0	0	0	0
	...	...								...								...							
	RED (255)	1	1	1	1	1	1	1	0	0	0	0	0	0	0	0	0	0	0	0	0	0	0	0	0
	RED (255)	1	1	1	1	1	1	1	1	0	0	0	0	0	0	0	0	0	0	0	0	0	0	0	0
GREEN	GREEN (000)	0	0	0	0	0	0	0	0	0	0	0	0	0	0	0	0	0	0	0	0	0	0	0	0
	GREEN (001)	0	0	0	0	0	0	0	0	0	0	0	0	0	0	0	1	0	0	0	0	0	0	0	0
	...	...								...								...							
	GREEN (255)	0	0	0	0	0	0	0	0	1	1	1	1	1	1	1	0	0	0	0	0	0	0	0	0
	GREEN (255)	0	0	0	0	0	0	0	0	1	1	1	1	1	1	1	1	0	0	0	0	0	0	0	0
BLUE	BLUE (000)	0	0	0	0	0	0	0	0	0	0	0	0	0	0	0	0	0	0	0	0	0	0	0	0
	BLUE (001)	0	0	0	0	0	0	0	0	0	0	0	0	0	0	0	0	0	0	0	0	0	0	0	1
	...	...								...								...							
	BLUE (254)	0	0	0	0	0	0	0	0	0	0	0	0	0	0	0	0	1	1	1	1	1	1	1	0
	BLUE (255)	0	0	0	0	0	0	0	0	0	0	0	0	0	0	0	0	1	1	1	1	1	1	1	1



## Product Specification

**3-6-3. Color Input Data Reference(262,144 color)**

The brightness of each primary color (red, green and blue) is based on the 6-bit gray scale data input for the color ; the higher the binary input, the brighter the color. The table below provides a reference for color versus data input. Please see “3-6-1. Input Condition of FRC signal and data signals” for 262,144 color.

**Table 8-2. COLOR DATA REFERENCE**

Color		Input Color Data																					
		RED						GREEN						BLUE									
		MSB						LSB		MSB						LSB		MSB					
		R5	R4	R3	R2	R1	R0	G5	G4	G3	G2	G1	G0	B5	B4	B3	B2	B1	B0				
Basic Color	Black	0	0	0	0	0	0	0	0	0	0	0	0	0	0	0	0	0	0				
	Red	1	1	1	1	1	1	0	0	0	0	0	0	0	0	0	0	0	0				
	Green	0	0	0	0	0	0	1	1	1	1	1	1	0	0	0	0	0	0				
	Blue	0	0	0	0	0	0	0	0	0	0	0	0	1	1	1	1	1	1				
	Cyan	0	0	0	0	0	0	1	1	1	1	1	1	1	1	1	1	1	1				
	Magenta	1	1	1	1	1	1	0	0	0	0	0	0	1	1	1	1	1	1				
	Yellow	1	1	1	1	1	1	1	1	1	1	1	1	0	0	0	0	0	0				
	White	1	1	1	1	1	1	1	1	1	1	1	1	1	1	1	1	1	1				
RED	RED (00)	0	0	0	0	0	0	0	0	0	0	0	0	0	0	0	0	0	0				
	RED (01)	0	0	0	0	0	1	0	0	0	0	0	0	0	0	0	0	0	0				
	...	...						...						...									
	RED (62)	1	1	1	1	1	0	0	0	0	0	0	0	0	0	0	0	0	0				
	RED (63)	1	1	1	1	1	1	0	0	0	0	0	0	0	0	0	0	0	0				
GREEN	GREEN (00)	0	0	0	0	0	0	0	0	0	0	0	0	0	0	0	0	0	0				
	GREEN (01)	0	0	0	0	0	0	0	0	0	0	0	1	0	0	0	0	0	0				
	...	...						...						...									
	GREEN (62)	0	0	0	0	0	0	1	1	1	1	1	0	0	0	0	0	0	0				
	GREEN (63)	0	0	0	0	0	0	1	1	1	1	1	1	0	0	0	0	0	0				
BLUE	BLUE (00)	0	0	0	0	0	0	0	0	0	0	0	0	0	0	0	0	0	0				
	BLUE (01)	0	0	0	0	0	0	0	0	0	0	0	0	0	0	0	0	0	1				
	...	...						...						...									
	BLUE (62)	0	0	0	0	0	0	0	0	0	0	0	0	1	1	1	1	1	0				
	BLUE (63)	0	0	0	0	0	0	0	0	0	0	0	0	1	1	1	1	1	1				

### 3-7. Power Sequence

#### 3-7-1. LCD Driving circuit

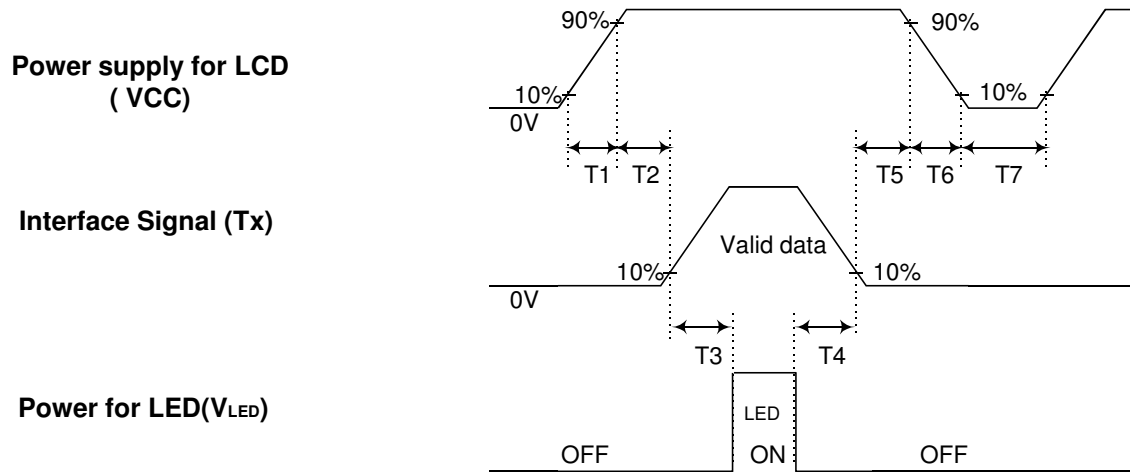
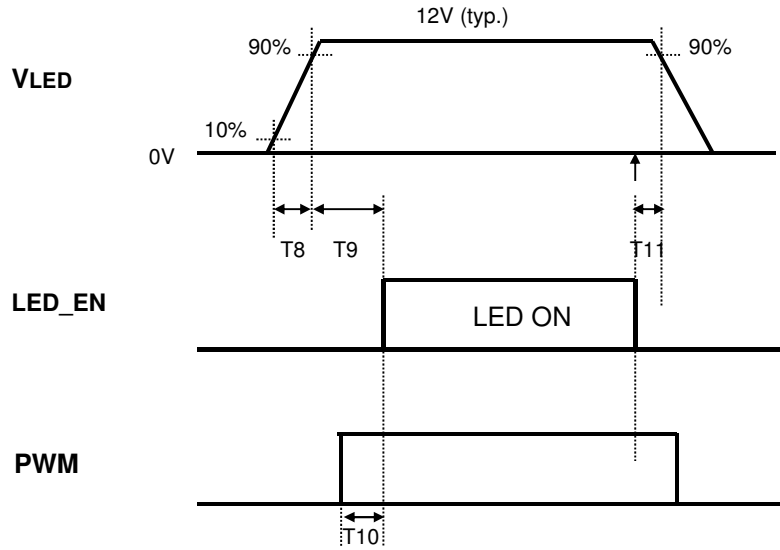

**Table 9. POWER SEQUENCE TABLE**

Parameter	Value			Units
	Min.	Typ.	Max.	
T <sub>1</sub>	-	-	10	(ms)
T <sub>2</sub>	10	-	50	(ms)
T <sub>3</sub>	200	-	-	(ms)
T <sub>4</sub>	200	-	-	(ms)
T <sub>5</sub>	0	-	50	(ms)
T <sub>6</sub>	-	-	10	(ms)
T <sub>7</sub>	2	-	-	(s)

Note)

1. Please avoid floating state of interface signal at invalid period.
2. When the interface signal is invalid, be sure to pull down the power supply for LCD VCC to 0V.
3. Lamp power must be turn on after power supply for LCD and interface signal are valid.

3-7-2. Sequence for LED Driver



Parameter	Value			Units
	Min.	Typ.	Max.	
T <sub>8</sub>	20	-	-	ms
T <sub>9</sub>	500	-	-	ms
T <sub>10</sub>	0	-	-	ms
T <sub>11</sub>	10	-	-	ms

Notes : 1. T<sub>8</sub> describes rising time of 0V to 12V and this parameter does not applied at restarting time.  
Even though T<sub>1</sub> is over the specified value, there is no problem if I<sup>2</sup>T spec of fuse is satisfied.

#### 4. Optical Specification

Optical characteristics are determined after the unit has been 'ON' and stable for approximately 30 minutes in a dark environment at 25°C. The values specified are at an approximate distance 50cm from the LCD surface at a viewing angle of  $\Phi$  and  $\Theta$  equal to 0°.

FIG. 3 presents additional information concerning the measurement equipment and method.

**FIG. 3 Optical Characteristic Measurement Equipment and Method**

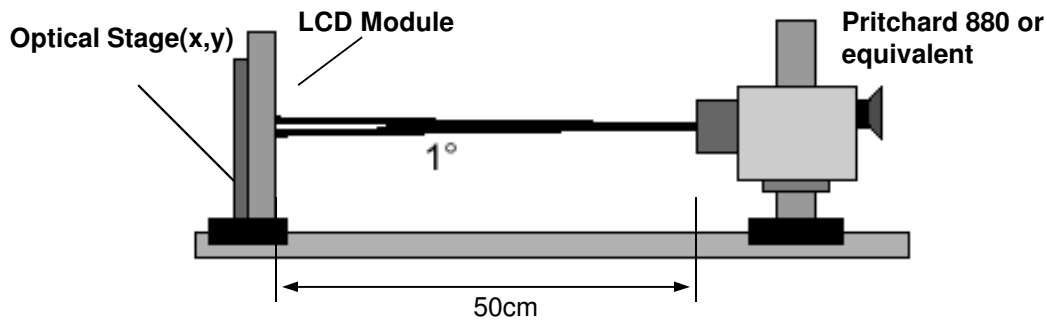

**Table 10. OPTICAL CHARACTERISTICS**

$T_a=25^\circ\text{C}$ ,  $V_{CC}=3.3\text{V}$ ,  $f_v=60\text{Hz}$ ,  $D_{clk}=38.5\text{MHz}$ ,  $\text{LED PWM}=100\%$

Parameter	Symbol	Values			Units	Notes
		Min	Typ	Max		
Contrast Ratio	CR	500	600	-		1
Surface Luminance, white		360	450		cd/m <sup>2</sup>	2
Luminance Variation	$\delta_{\text{WHITE}}$	-	1.25	1.45		3
Response Time						4
Rise Time	$T_{rR}$	-	10	20	ms	
Decay Time	$T_{rD}$	-	20	30	ms	
Color Coordinates						
WHITE	$W_x$		0.304			
	$W_y$		0.320			
RED	$R_x$		0.631			
	$R_y$		0.330			
GREEN	$G_x$	Typ -0.03	0.324	Typ +0.03		
	$G_y$		0.619			
BLUE	$B_x$		0.150			
	$B_y$		0.051			
Viewing Angle						5
x axis, right( $\Phi=0^\circ$ )	$\Theta_r$	65	70	-	degree	
x axis, left( $\Phi=180^\circ$ )	$\Theta_l$	65	70	-	degree	
y axis, up ( $\Phi=90^\circ$ )	$\Theta_u$	50	55	-	degree	
y axis, down ( $\Phi=270^\circ$ )	$\Theta_d$	60	65	-	degree	

Product Specification

Note)

1. Contrast Ratio(CR) is defined mathematically as

$$\text{Contrast Ratio} = \frac{\text{Surface Luminance with all white pixels}}{\text{Surface Luminance with all black pixels}}$$

2. Surface luminance is the center point across the LCD surface 50cm from the surface with all pixels displaying white. For more information see FIG 3.

3. The variation in surface luminance , The Panel total variation ( $\delta_{\text{WHITE}}$ ) is determined by measuring  $L_N$  at each test position 1 through 5, and then dividing the maximum  $L_N$  of 5 points luminance by minimum  $L_N$  of 5 points luminance. For more information see FIG 4.

$$\delta_{\text{WHITE}} = \text{Maximum}(L_1, L_2, \dots L_5) / \text{Minimum}(L_1, L_2, \dots L_5)$$

4. Response time is the time required for the display to transition from white to black (rise time,  $Tr_R$ ) and from black to white(Decay Time,  $Tr_D$ ). For additional information see FIG 5.

5. Viewing angle is the angle at which the contrast ratio is greater than 10. The angles are determined for the horizontal or x axis and the vertical or y axis with respect to the z axis which is normal to the LCD surface. For more information see FIG 6.

6. Gray scale specification

\*  $f_V=60\text{Hz}$

Gray Level	Luminance [%] (Typ)
L0	0.2
L31	0.8
L63	4.0
L95	10.5
L127	19.5
L159	33.0
L191	52.0
L223	75.0
L255	100

FIG. 4 Luminance

<measuring point for surface luminance & measuring point for luminance variation>

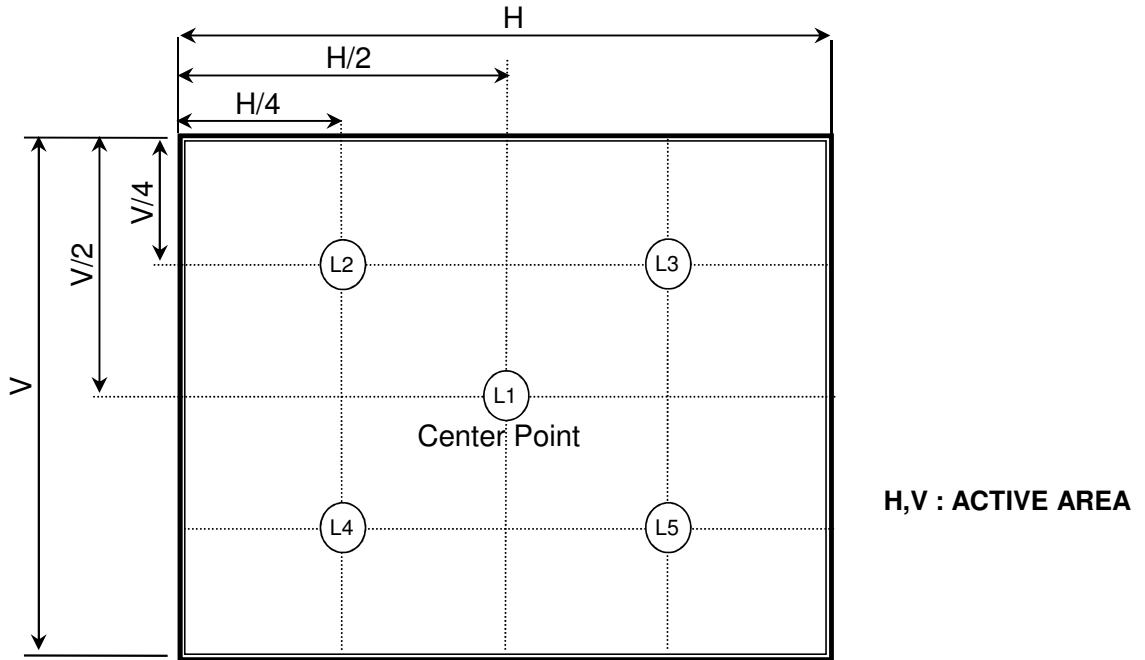

FIG. 5 Response Time

The response time is defined as the following figure and shall be measured by switching the input signal for “black” and “white”.

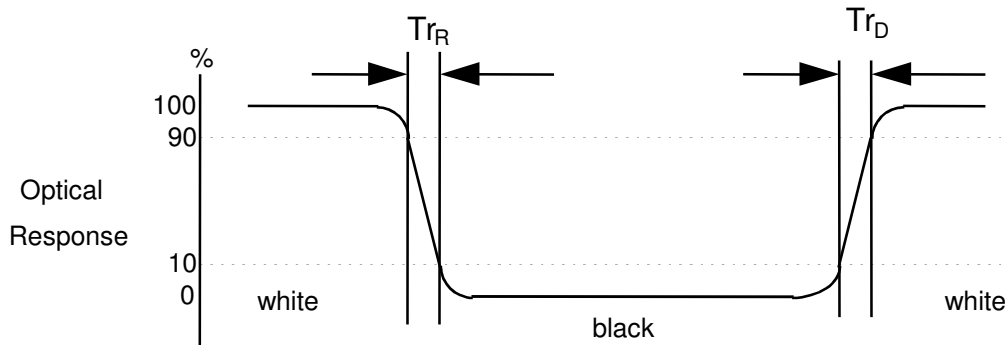
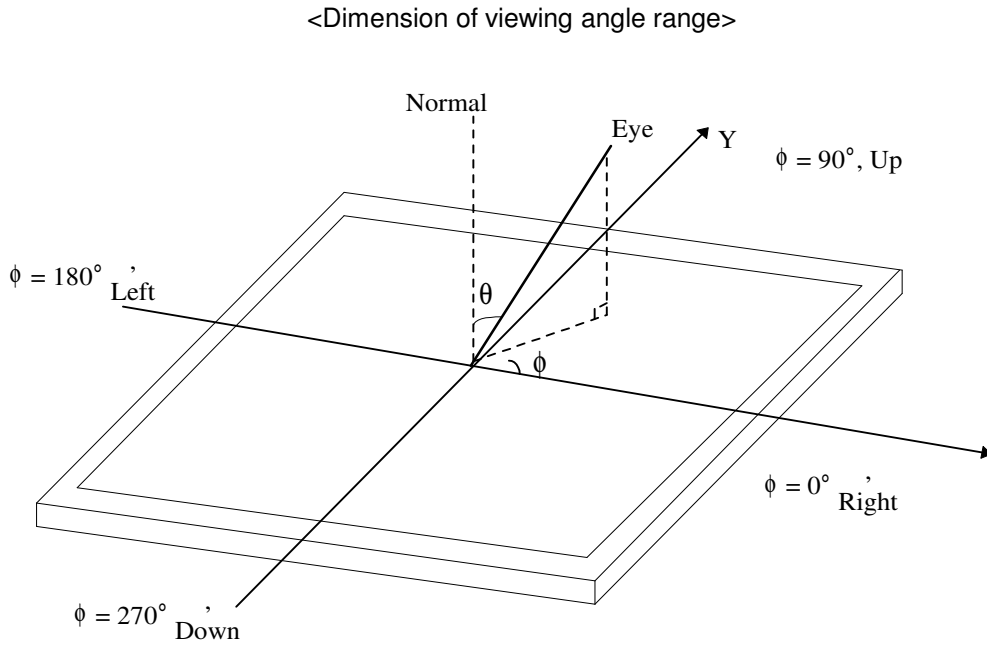

FIG. 6 Viewing angle



## 5. Mechanical Characteristics

The contents provide general mechanical characteristics for the model LB121S03-TL05. In addition the figures in the next page are detailed mechanical drawing of the LCD.

PARAMETER	SPECIFICATION	
Outline Dimension	Horizontal	276.0 ± 0.5mm
	Vertical	209.0 ± 0.5mm
	Depth	9 (Typ)
Active Display Area	Horizontal	246.0 mm
	Vertical	184.5 mm
Weight	530g (Max.)	
Surface Treatment	Anti-glare treatment	







## Product Specification

**6. Reliability**

Environment test condition

No.	Test Item	Conditions
1	High temperature storage test	Ta= 80°C, 240h
2	Low temperature storage test	Ta= -30°C, 240h
3	High temperature operation test	Ta= 70°C, 240h
4	Low temperature operation test	Ta= -20°C, 240h
5	Vibration test (non-operating)	Random, 10 ~ 300Hz, 1Grms,3 axis, 30min/axis
6	Shock test (non-operating)	Half sine wave, 120G, 2ms one shock of each six faces(I.e. run 180G 6ms for all six faces)
7	Altitude operating storage / shipment	0 ~ 10,000 feet (3,048m) 24Hr 0 ~ 40,000 feet (12,192m) 24Hr

{ Result Evaluation Criteria }

1. Evaluation should be tested after storage at room temperature for 24 hours.
2. There should be no change which might affect the practical display function when the display test quality test is conducted under normal operating condition.

## 7. International Standards

### 7-1. Safety

- a) UL 60950-1, Underwriters Laboratories Inc.  
Information Technology Equipment - Safety - Part 1 : General Requirements.
- b) CAN/CSA-C22.2 No. 60950-1-07, Canadian Standards Association.  
Information Technology Equipment - Safety - Part 1 : General Requirements.
- c) EN 60950-1, European Committee for Electrotechnical Standardization (CENELEC).  
Information Technology Equipment - Safety - Part 1 : General Requirements.

### 7-2. EMC

- a) ANSI C63.4 "American National Standard for Methods of Measurement of Radio-Noise Emissions from Low-Voltage Electrical and Electronic Equipment in the Range of 9 kHz to 40 GHz." American National Standards Institute (ANSI), 2003.
- b) CISPR 22 "Information technology equipment – Radio disturbance characteristics – Limit and methods of measurement." International Special Committee on Radio Interference (CISPR), 2005.
- c) CISPR 13 "Sound and television broadcast receivers and associated equipment – Radio disturbance characteristics – Limits and method of measurement." International Special Committee on Radio Interference (CISPR), 2006.

### 7-3. Environment

- a) RoHS, Directive 2011/65/EU of the European Parliament and of the council of 8 June 2011

Product Specification

## 8. Packing

### 8-1. Designation of Lot Mark

a) Lot Mark

A	B	C	D	E	F	G	H	I	J	K	L	M
---	---	---	---	---	---	---	---	---	---	---	---	---

A,B,C : SIZE(INCH)

E : MONTH

N~Q: INTERNAL CODE(NO DIGIT)

D : YEAR

F ~ M : SERIAL NO.

Note

1. YEAR

Year	2011	2012	2013	2014	2015	2016	2017	2018	2019	2020
Mark	A	B	C	D	E	F	G	H	J	K

2. MONTH

Month	Jan	Feb	Mar	Apr	May	Jun	Jul	Aug	Sep	Oct	Nov	Dec
Mark	1	2	3	4	5	6	7	8	9	A	B	C

b) Location of Lot Mark

Serial No. is printed on the label. The label is attached to the backside of the LCD module.  
This is subject to change without prior notice.

### 8-2. Packing Form

a) Package quantity in one box : 16 pcs

b) Box Size : 425mm × 328mm × 350mm

**Product Specification****9. PRECAUTIONS**

Please pay attention to the followings when you use this TFT LCD module.

**9-1. MOUNTING PRECAUTIONS**

- (1) You must mount a module using holes arranged in four corners or four sides.
- (2) You should consider the mounting structure so that uneven force (ex. Twisted stress) is not applied to the module. And the case on which a module is mounted should have sufficient strength so that external force is not transmitted directly to the module.
- (3) Please attach the surface transparent protective plate to the surface in order to protect the polarizer. Transparent protective plate should have sufficient strength in order to resist external force.
- (4) You should adopt radiation structure to satisfy the temperature specification.
- (5) Acetic acid type and chlorine type materials for the cover case are not desirable because the former generates corrosive gas of attacking the polarizer at high temperature and the latter causes circuit break by electro-chemical reaction.
- (6) Do not touch, push or rub the exposed polarizers with glass, tweezers or anything harder than HB pencil lead. And please do not rub with dust clothes with chemical treatment. Do not touch the surface of polarizer for bare hand or greasy cloth.(Some cosmetics are detrimental to the polarizer.)
- (7) When the surface becomes dusty, please wipe gently with absorbent cotton or other soft materials like chamois soaks with petroleum benzene. Normal-hexane is recommended for cleaning the adhesives used to attach front / rear polarizers. Do not use acetone, toluene and alcohol because they cause chemical damage to the polarizer.
- (8) Wipe off saliva or water drops as soon as possible. Their long time contact with polarizer causes deformations and color fading.
- (9) Do not open the case because inside circuits do not have sufficient strength.
- (10) As The IPS panel is sensitive & slim, please recommend the metal frame of the system supports the panel by the double side-mount.

**9-2. OPERATING PRECAUTIONS**

- (1) The spike noise causes the mis-operation of circuits. It should be lower than following voltage :  
 $V = \pm 200\text{mV}$  (Over and under shoot voltage)
- (2) Response time depends on the temperature. (In lower temperature, it becomes longer.)
- (3) Brightness depends on the temperature. (In lower temperature, it becomes lower.)  
And in lower temperature, response time (required time that brightness is stable after turned on) becomes longer.
- (4) Be careful for condensation at sudden temperature change. Condensation makes damage to polarizer or electrical contacted parts. And after fading condensation, smear or spot will occur.
- (5) When fixed patterns are displayed for a long time, remnant image is likely to occur.
- (6) Module has high frequency circuits. Sufficient suppression to the electromagnetic interference shall be done by system manufacturers. Grounding and shielding methods may be important to minimize the interference.
- (7) Please do not give any mechanical and/or acoustical impact to LCM. Otherwise, LCM can't be operated its full characteristics perfectly.
- (8) A screw which is fastened up the steels should be a machine screw.  
(if not, it causes metallic foreign material and deal LCM a fatal blow)
- (9) Please do not set LCD on its edge.
- (10) When LCMs are used for public display defects such as Yogure, image sticking can not be guaranteed.

### **9-3. ELECTROSTATIC DISCHARGE CONTROL**

Since a module is composed of electronic circuits, it is not strong to electrostatic discharge. Make certain that treatment persons are connected to ground through wrist band etc. And don't touch interface pin directly.

### **9-4. PRECAUTIONS FOR STRONG LIGHT EXPOSURE**

Strong light exposure causes degradation of polarizer and color filter.

### **9-5. STORAGE**

When storing modules as spares for a long time, the following precautions are necessary.

- (1) Store them in a dark place. Do not expose the module to sunlight or fluorescent light. Keep the temperature between 5°C and 35°C at normal humidity.
- (2) The polarizer surface should not come in contact with any other object.  
It is recommended that they be stored in the container in which they were shipped.

### **9-6. HANDLING PRECAUTIONS FOR PROTECTION FILM**

- (1) The protection film is attached to the bezel with a small masking tape.  
When the protection film is peeled off, static electricity is generated between the film and polarizer.  
This should be peeled off slowly and carefully by people who are electrically grounded and with well ion-blown equipment or in such a condition, etc.
- (2) When the module with protection film attached is stored for a long time, sometimes there remains a very small amount of glue still on the bezel after the protection film is peeled off.
- (3) You can remove the glue easily. When the glue remains on the bezel surface or its vestige is recognized, please wipe them off with absorbent cotton waste or other soft material like chamois soaked with normal-hexane.