

TFT-DISPLAY DATASHEET

DATA IMAGE

Model: FX1001P2DSSWMG01

BRIEF SPEC.:

Main Feature	Landscape Normally Black Wide Viewing Angle
Active Screen Area	216.96 x 135.6 [mm]
Diagonal Format	10.1" 16:10
Resolution	1280 X 800
Colors	8 Bit
Backlight	Black
Brightness	1000 cd/m ²
LED Life Time	50K(h)
Interface	LVDS
Viewing Angle	85/85 L/R 85/85
Touchscreen	no
Power Supply	3.3V (Typ.)
Module Outline	231 x 153.8 x 10.2 [mm]
Operation Temperature	-20 ... +70 °C
Storage Temperature	-30... +80 °C
Surface Treatment	Glare Hard Coating





DATA IMAGE CORPORATION

TFT Module Specification Preliminary

ITEM NO.: FX1001P2DSSWMG01

Table of Contents

1. COVER & CONTENTS	1
2. RECORD OF REVISION	2
3. GENERAL SPECIFICATIONS	3
4. ABSOLUTE MAXIMUM RATINGS	3
5. ELECTRICAL CHARACTERISTICS	3
6. INPUT SIGNAL CHARACTERISTICS	5
7. OPTICAL CHARACTERISTIC	7
8. BLOCK DIAGRAM	9
9. PIN CONNECTIONS	10
10. QUALITY ASSURANCE	12
11. LCM PRODUCT LABEL DEFINE.....	16
12. PRECAUTIONS IN USE LCM	18
13. OUTLINE DRAWING	19
14. PACKAGE INFORMATION.....	20

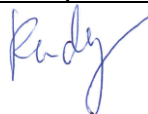
Customer Companies	QA Approved	DQA Check	R&D Approved	R&D Check
				
Customer Approved by	Version:	Issued Date:	Total Pages:	Prepared
	1	30/JAN/16'	20	

2. RECORD OF REVISION

Rev	Date	Item	Page	Comment	Source
1	30/JAN/16'			Initial Preliminary	ESR0411002

3. GENERAL SPECIFICATIONS

Parameter	Specifications	Unit
Screen Size	10.1 (diagonal)	inch
Display Format	1280(H) x (R,G,B) x 800(V)	dot
Active Area	216.96(W) x 135.6(H)	mm
Pixel Pitch	0.1695(W) x 0.1695(H)	mm
Pixel Configuration	RGB-Stripe	
Outline Dimension	231 (W) x153.8 (H) x10.2 _{MAX} (D)	mm
Surface treatment	Glare , Hard -Coating	
Display Mode	Normally Black	
Interface	LVDS	
Viewing Direction	All	
Weight	TBD	g
Display mode	Normally Black, Transmissive	
Our components and processes are compliant to RoHS standard		

4. ABSOLUTE MAXIMUM RATINGS

Parameter	Symbol	Min.	Max.	Unit	Remark
Power voltage	VDD	-0.3	7	V	Note2
Logic input signal voltage	V _{Signal}	3.0	3.6		
Power voltage for LED	LED_VCCS	-0.3	30	V	
Operating temperature	TOP	-20	70	°C	
Storage temperature	TST	-30	80	°C	

Note 1: Permanent damage may occur to the LCD module if beyond this specification. Functional operation should be restricted to the conditions described under normal operating conditions.

Note 2: Operating temperature 25°C, humidity 55%RH.

5. ELECTRICAL CHARACTERISTICS

5.1 Typical Operation Conditions

Parameter	Symbol	Min.	Typ.	Max.	Unit	Remark	
Power voltage	VDD	3.0	3.3	3.6	V	Note 2,4	
VDD Current	White Pattern	I _{DD}	-	0.27	-	A	Note 3,4
VDD Power Consumption	White Pattern	P _{DD}	-	-	1.0	W	
Rush Current		I _{Rush}	-	-	1.5	A	Note 1,4,5
Allowable Logic/LCD Drive Ripple Voltage	V _{VDD-RP}	-	-	300	mV	Note 4	
Power voltage for LED	LED_VCCS	10.8	12	13.2	V		
Power current for LED	I _{LED_VCCS}		620	800	mA	LED_VCCS=12V	
LED_PWM Signal Logic Voltage	High	V _{PWM}	2	-	LED_VCCS	V	
	Low		0	-	0.8	V	
LED_PWM Frequency	FPWM	100	-	1000	Hz		
LED_PWM duty		1		100	%		
LED Life Time		50000			hrs	Note 6	

Note 1 : Measure Condition

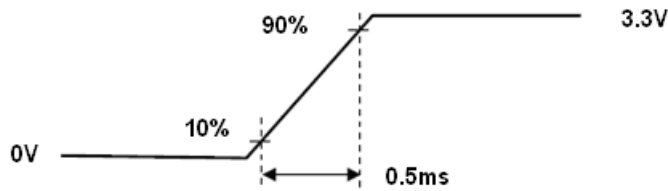

VDD Rising Time

Note 2 : VDD Power Dip Condition

$V_{TH} < V_{DD} \leq V_{min}$, $t_d \leq 10ms$ (a time of the voltage return to normal), our panel can revive automatically.

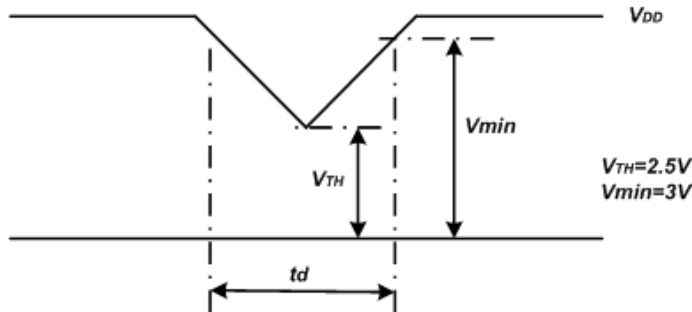

VDD Power Dip

Note 3 : Frame Rate=60Hz, VDD=3.3V, DC Current.

Note 4 : Operating temperature 25°C, humidity 55%RH.

Note 5 : The reference measurement circuit of rush current.

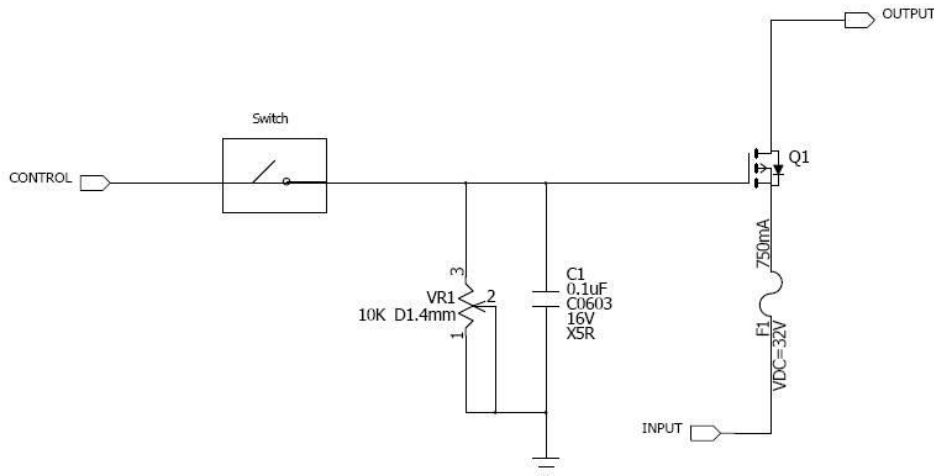

Note 6: The “LED life time” is defined as the module brightness decrease to 50% original brightness at $T_a=25^\circ C$.

6. INPUT SIGNAL CHARACTERISTICS

6.1 LVDS Receiver

Parameter	Symbol	Min.	Typ.	Max.	Unit	Remark
Differential input high Threshold voltage	RXVTH	-	-	+100	mV	VCM=1.2V
Differential input low Threshold voltage	RXVTL	-100	-	-	mV	
Differential voltage	VID	200	-	400	mV	
Common Mode Voltage	V _{CM}	0.3+(VID/2)	-	VDD-1.2-(VID/2)	V	
Common Mode Voltage	ΔV _{CM}	-	-	50	mV	VCM=1.2V

Note 1 : Input signals shall be low or Hi- resistance state when VDD is off.

Note 2 : All electrical characteristics for LVDS signal are defined and shall be measured at the interface connector of LCD.

Voltage Definitions

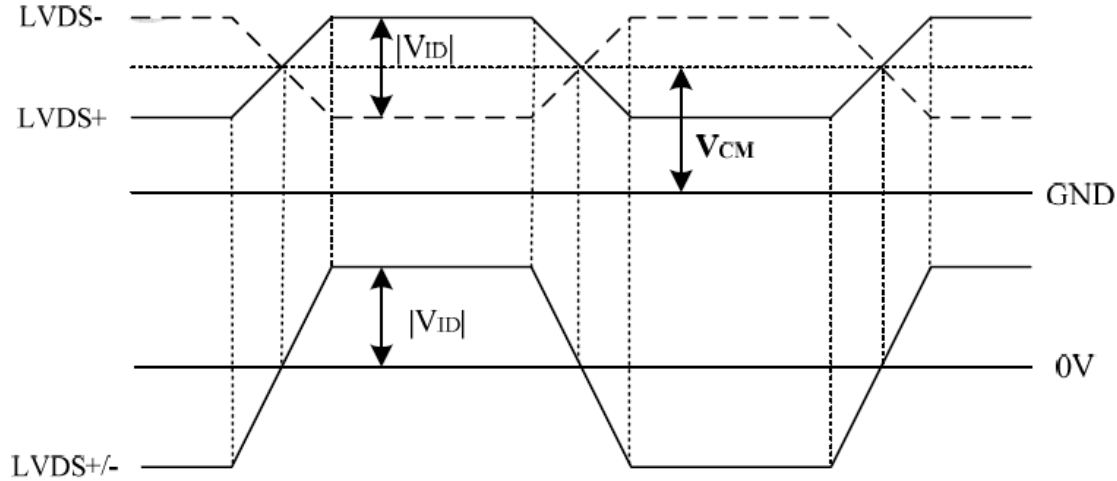

LVDS Data Mapping

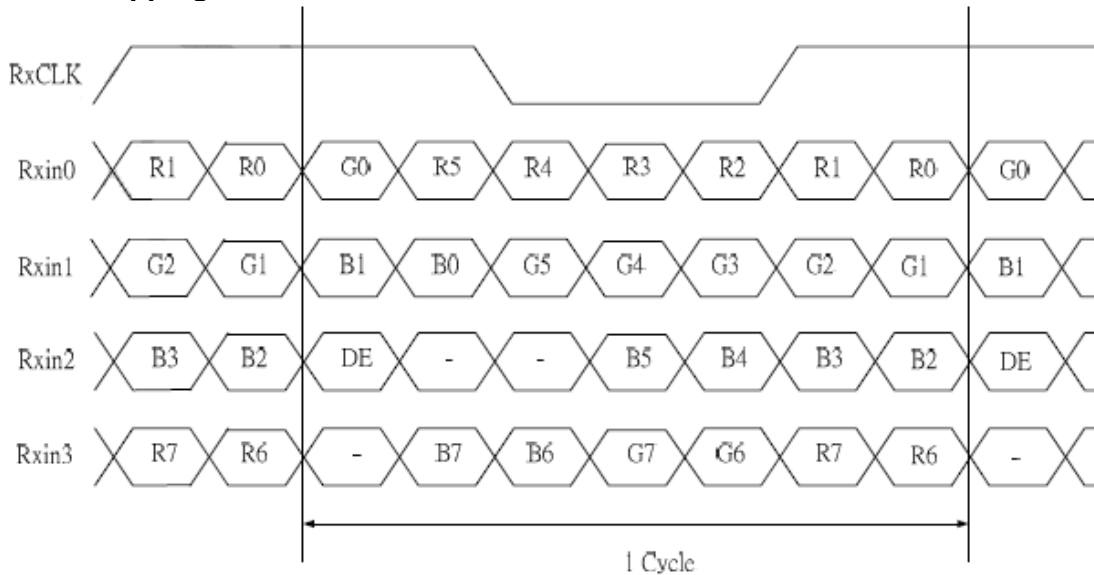

6.2 Interface Timings

Parameter	Symbol	Min.	Typ.	Max.	Unit	Remark
Frame Rate	-	-	60	-	Hz	
Frame Period	tv	815	823	1023	line	
Vertical display area	tvd	800			line	
Vertical Blanking Time	tVW+tvBP+tvFP	15	23	33	line	
1 Line Scanning Time	tH	1410	1440	1470	clock	
Horizontal Display Time	tHD	1280			clock	
Horizontal Blanking Time	tHW+tHBP+tHFP	60	160	190	clock	
Clock Rate	1/Tc	68.9	71.1	73.4	MHz	

7. OPTICAL CHARACTERISTIC

Parameter	Symbol	Condition	Min.	Typ.	Max.	Unit	Remarks
Viewing Angle (CR≥10)	θ_L	$\Phi=180^\circ$ (9 o'clock)	75	85	-	deg	Note 1
	θ_R	$\Phi=0^\circ$ (3 o'clock)	75	85	-		
	θ_T	$\Phi=90^\circ$ (12 o'clock)	75	85	-		
	θ_B	$\Phi=270^\circ$ (6 o'clock)	75	85	-		
Contrast Ratio	CR	Normal $\theta=\Phi=0^\circ$	600	800	-		Note 4
Response time	Rising +Falling		-	25	50	ms	Note 3
Color chromaticity	Rx		Typ. -0.05	Typ. +0.05	0.569	-	Note 5
	Ry				0.335	-	
	Gx				0.339	-	
	Gy				0.568	-	
	Bx				0.160	-	
	By				0.127	-	
	Wy				0.329	-	
Luminance	L		900	1000	-	cd/m ²	
Luminance uniformity	YU	70	75	-	%	Note 6	

Test Conditions:

- VDD=3.3V, LED_VCCS=12V, LED_PWM=100%Duty, the ambient temperature is 25°C.
- The test systems refer to Note 2.

Note 1: Definition of viewing angle range

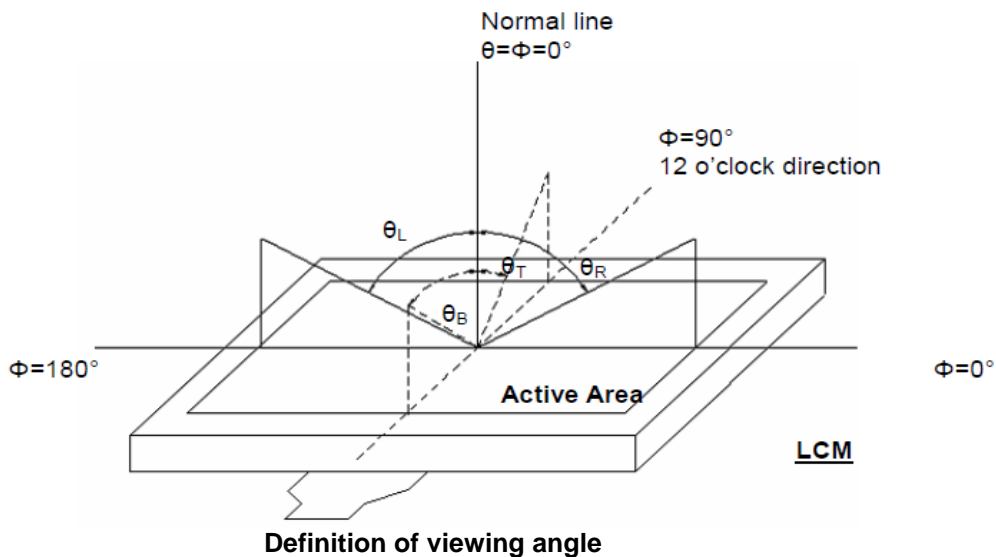

Note 2: Definition of optical measurement system.

The optical characteristics should be measured in dark room. After 2 minutes operation, the optical properties are measured at the center point of the LCD screen. (Viewing angle is measured by ELDIM-EZ contrast/Height :1.2mm, other items are measured by BM-7A/ Field of view: 1° /Height: 500mm.)

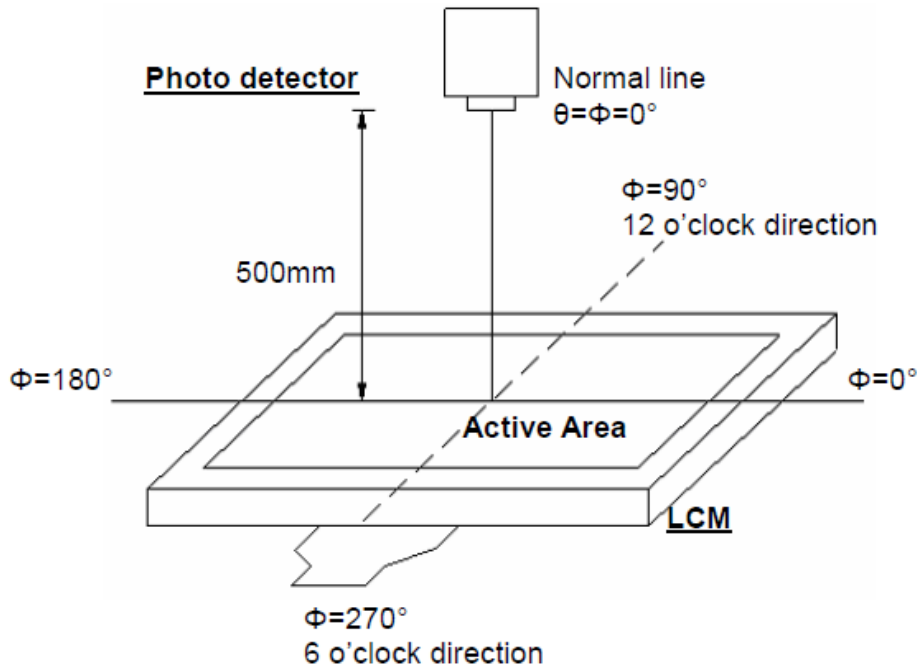

Optical measurement system setup

Note 3: Definition of Response time

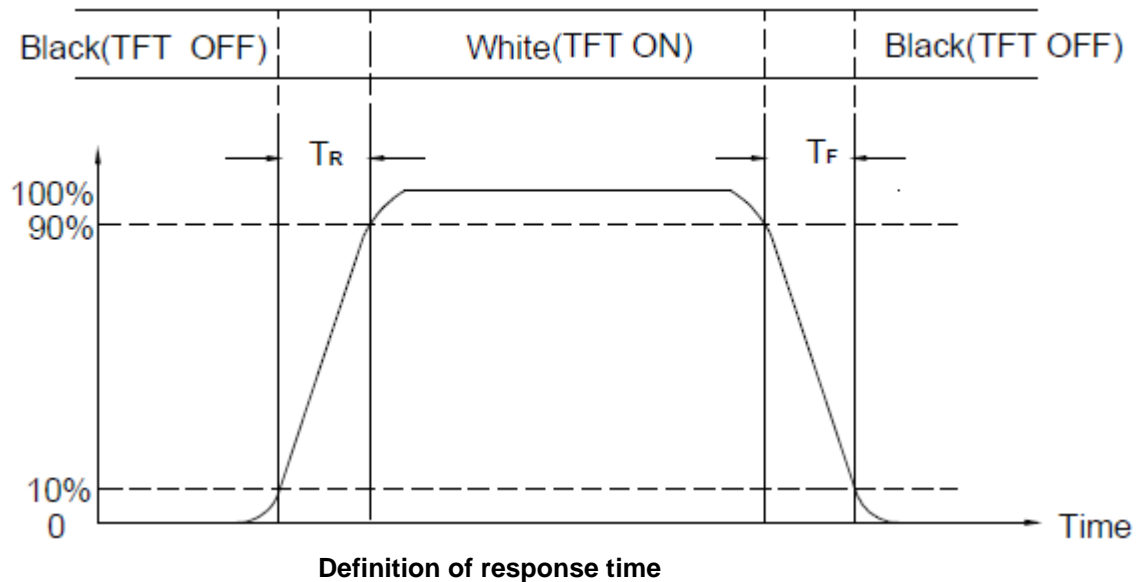

Note 4: Definition of contrast ratio

$$\text{Contrast ratio (CR)} = \frac{\text{Luminance measured when LCD on the "White" state}}{\text{Luminance measured when LCD on the "Black" state}}$$

Note 5: Definition of color chromaticity (CIE1931)
Color coordinates measured at center point of LCD.

Note 6: Measuring the center area of the panel. The LED driving condition is LED_VCCS=12V

Note 7: Definition of Luminance Uniformity
Active area is divided into 9 measuring areas. Every measuring point is placed at the center of each measuring area.

$$\text{Luminance Uniformity (Yu)} = \frac{B_{min}}{B_{max}}$$

L-----Active area length W----- Active area width

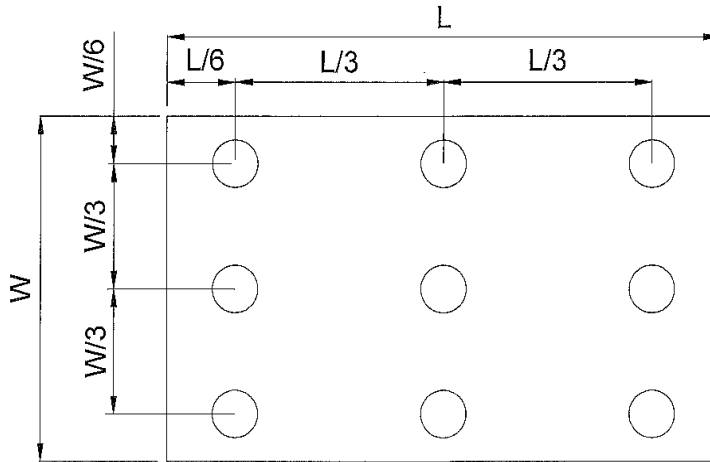

8. BLOCK DIAGRAM

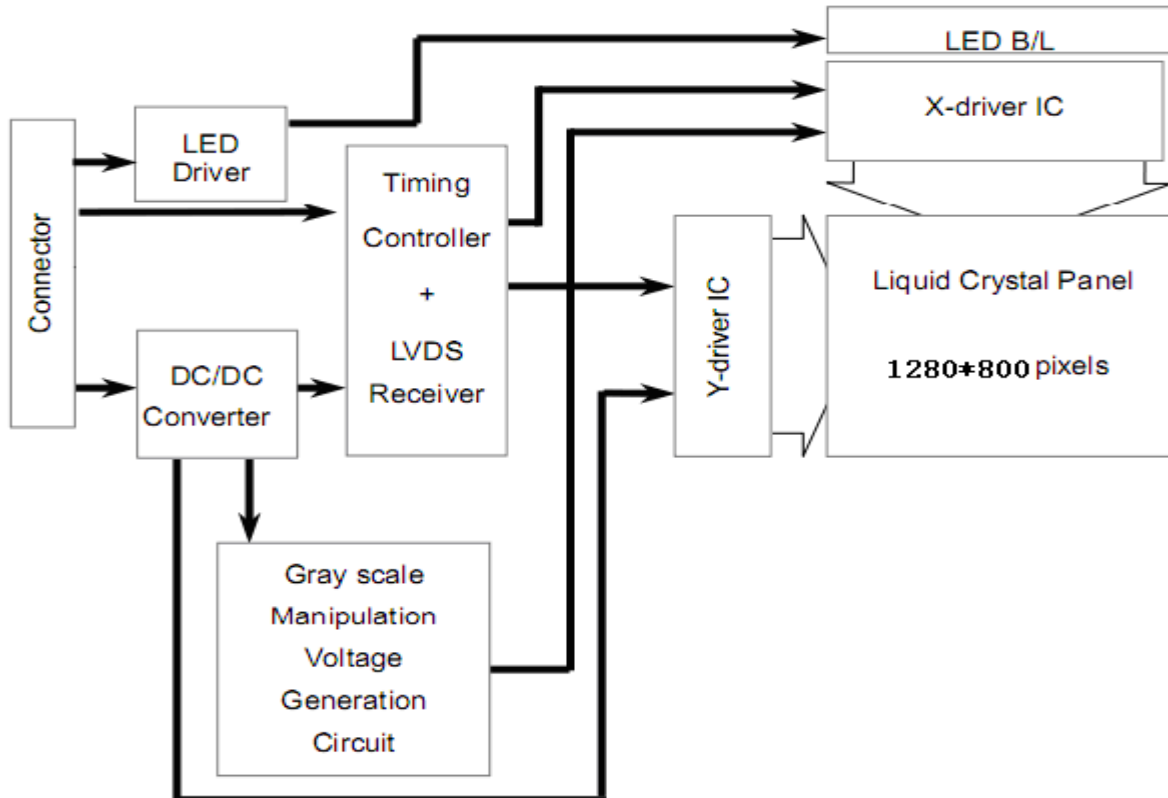

9. PIN CONNECTIONS

Pin No.	Symbol	Function	Remark
1	NC	No Connection	
2	VDD(3.3V)	Power Supply 3.3V	
3	VDD(3.3V)	Power Supply	
4	NC	No Connection	
5	NC	No Connection	
6	NC	No Connection	
7	NC	No Connection	
8	RXIN0-	-LVDS Differential Data Input	
9	RXIN0+	+LVDS Differential Data Input	
10	VSS	Ground	
11	RXIN1-	-LVDS Differential Data Input	
12	RXIN1+	+LVDS Differential Data Input	
13	VSS	Ground	
14	RXIN2-	-LVDS Differential Data Input	
15	RXIN2+	+LVDS Differential Data Input	
16	VSS	Ground	
17	RXCLK-	-LVDS Differential Clock Input	
18	RXCLK+	+LVDS Differential Clock Input	
19	VSS	Ground	
20	RXIN3-	-LVDS Differential Data Input	
21	RXIN3+	+LVDS Differential Data Input	
22	VSS	Ground	
23	VSS	Ground	
24	VSS	Ground	
25	VSS	Ground	
26	NC	No Connection	
27	LED_PWM	PWM Input Signal for LED Driver	
28	NC	No Connection	
29	NC	No Connection	
30	NC	No Connection	
31	LED_VCCS(+12V)	LED Power Supply (+12V)	
32	LED_VCCS(+12V)	LED Power Supply (+12V)	
33	LED_VCCS(+12V)	LED Power Supply (+12V)	
34	NC	No Connection	
35	NC	No Connection	
36	NC	No Connection	
37	NC	No Connection	
38	NC	No Connection	
39	NC	No Connection	
40	NC	No Connection	

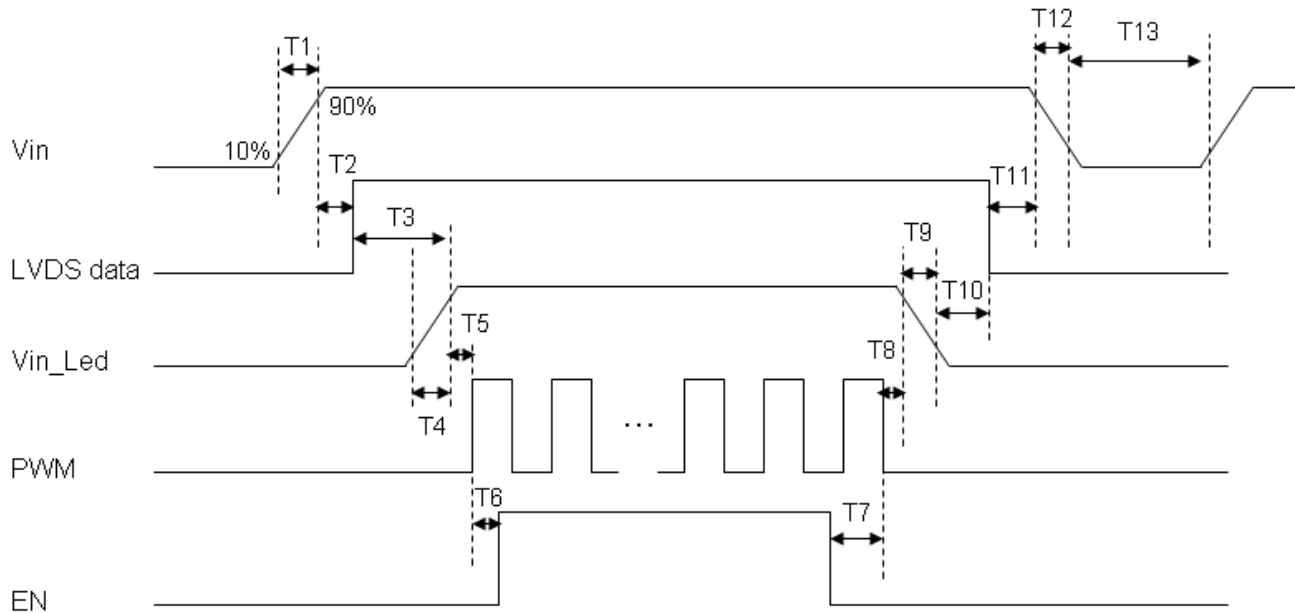
Power ON/OFF Sequence

Power Sequencing Requirements

Parameter	Symbol	Min.	Typ.	Max.	Unit
VIN Rise Time	T1	0.5	--	10	ms
VIN Good to Signal Valid	T2	30	--	90	ms
Signal Valid to Backlight On	T3	200	--	--	ms
Backlight Power on Time	T4	0.5	--	--	ms
Backlight VDD Good to System PWM on	T5	10	--	--	ms
System PWM on to Backlight Enable on	T6	10	--	--	ms
Backlight Enable off to System PWM off	T7	0	--	--	ms
System PWM off to B/L Power Disable	T8	10	--	--	ms
Backlight Power off Time	T9	0.5	10	30	
Backlight Off to Signal Disable	T10	200	--	--	ms
Signal Disable to Power Down	T11	0	--	50	ms
VIN Fall Time	T12	0.5	10	30	ms
Power Off	T13	500	--	--	ms

10. QUALITY ASSURANCE

10.1. Test Conditions

10.1.1 Temperature and Humidity(Ambient Temperature)

Temperature : $25 \pm 5^{\circ}\text{C}$

Humidity : $65 \pm 5\%$

10.1.2 Operation

Unless specified otherwise, test will be conducted under function state.

10.1.3 Container

Unless specified otherwise, vibration test will be conducted to the product itself without putting it in a container.

10.1.4 Test Frequency

In case of related to deterioration such as shock test. It will be conducted only once.

10.1.5 Test Method

No.	Item	Test Conditions	Remark
1	High Temperature Storage Test	Ta=80°C, 240hrs	IEC68-2-2
2	Low Temperature Storage Test	Ta=-30°C, 240hrs	IEC68-2-1
3	High Temperature Operation Test	Ts=70°C, 240hrs	IEC68-2-2
4	Low Temperature Operation Test	Ta=-20°C, 240hrs	IEC68-2-1
5	High Temperature and High Humidity Operation Test	T=60°C,90%RH,240hrs	IEC68-2-3
6	Thermal cycling storage test	-30°C ----25°C -----80°C ,200Cycle 30min 5min 30min	IEC68-2-14
7	vibration test	Frequency:10~55HZ Amplitude:1.5mm Sweep time:11min Test period:6Cycles for each direction of X,Y,Z	IEC68-2-6
8	Drop test	Height :60cm 1 conner,3edges,6surfaces	IEC68-2-32
9	Shock test	100G,6ms,Direction:±X±Y±Z Cycle:3times	IEC68-2-27
10	ESD test	Location: LCM/TP surface Condition:150pf 330Ω Contact +/- 8kV Air +/-15kV Criteria: Class C	IEC61000-4-2

10.2 Inspection condition

10.2.1 Inspection conditions

10.2.1.1 Inspection Distance : 35 ± 5 cm

10.2.1.2 View Angle :

- (1) Inspection under operating condition : $\pm 5^\circ$
- (2) Inspection under non-operating condition : $\pm 45^\circ$

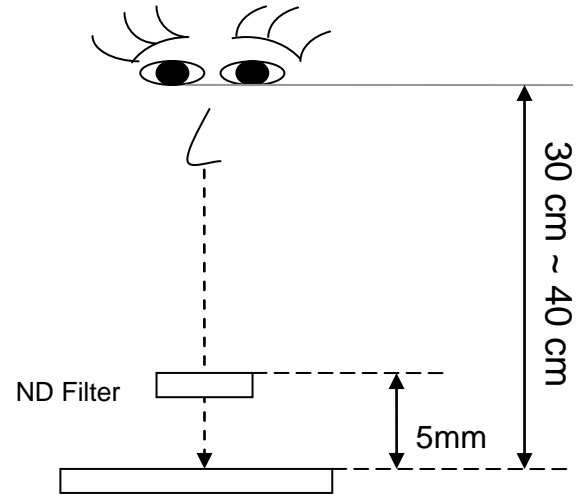
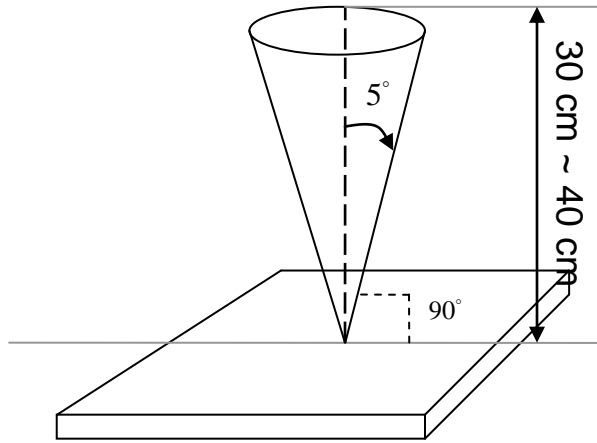

10.2.2 Environment conditions :

Ambient Temperature :		$25 \pm 5^\circ\text{C}$
Ambient Humidity :		$65 \pm 5\%$
Ambient Illumination	Cosmetic Inspection	400 ~ 600lux
	Functional Inspection	300 ~ 500lux

10.2.3 Definition of applicable Zones



10.3 Inspection Parameters

No.	Parameter	Criteria																		
1	Operating	Display function: No Display malfunction (Major)																		
		Contrast ratio (Black, White): Does not meet specified range in the spec. (Major) (Note:3)																		
		Line Defect: No obvious Vertical and Horizontal line defect in bright, dark and colored. (Major) (Note:1)																		
		Point Defect (Red, green, blue, dark): Active area ≤ 8 dots (Minor)(Note:1)																		
		<table border="1"> <thead> <tr> <th>Item</th> <th>Acceptable number</th> <th>Total</th> <th>Class Of Defects</th> <th>AQL Level</th> </tr> </thead> <tbody> <tr> <td>Bright</td> <td>4</td> <td rowspan="2">8</td> <td rowspan="4">Minor</td> <td rowspan="4">1.5</td> </tr> <tr> <td>Dark</td> <td>4</td> </tr> <tr> <td>Adjacent Bright</td> <td>1</td> <td>1</td> </tr> <tr> <td>Adjacent Dark</td> <td>1</td> <td>1</td> </tr> </tbody> </table>	Item	Acceptable number	Total	Class Of Defects	AQL Level	Bright	4	8	Minor	1.5	Dark	4	Adjacent Bright	1	1	Adjacent Dark	1	1
		Item	Acceptable number	Total	Class Of Defects	AQL Level														
		Bright	4	8	Minor	1.5														
		Dark	4																	
		Adjacent Bright	1	1																
		Adjacent Dark	1	1																
Non-uniformity: Visible through 2%ND filter white, R, G, B and gray 50%pattern. (Minor)																				
Foreign material in Black or White spots shape ($W > 1/4L$) (Note: 5)																				
<table border="1"> <thead> <tr> <th>Dimension</th> <th>Acceptable number</th> <th>Class Of Defects</th> <th>AQL Level</th> </tr> </thead> <tbody> <tr> <td>$D \leq 0.3$</td> <td>*</td> <td rowspan="3">Minor</td> <td rowspan="3">1.5</td> </tr> <tr> <td>$0.3 < D \leq 0.5$</td> <td>4</td> </tr> <tr> <td>$D > 0.5$</td> <td>0</td> </tr> </tbody> </table>	Dimension	Acceptable number	Class Of Defects	AQL Level	$D \leq 0.3$	*	Minor	1.5	$0.3 < D \leq 0.5$	4	$D > 0.5$	0								
Dimension	Acceptable number	Class Of Defects	AQL Level																	
$D \leq 0.3$	*	Minor	1.5																	
$0.3 < D \leq 0.5$	4																			
$D > 0.5$	0																			
$D = (\text{Long} + \text{Short}) / 2$ * : Disregard																				
Foreign Material in Line or spiral shape ($W \leq 1/4L$) (Note: 4)																				
<table border="1"> <thead> <tr> <th>Dimension</th> <th>Acceptable number</th> <th>Class Of Defects</th> <th>AQL Level</th> </tr> </thead> <tbody> <tr> <td>$W > 0.1\text{mm}, L > 5\text{mm}$</td> <td>0</td> <td rowspan="3">Minor</td> <td rowspan="3">1.5</td> </tr> <tr> <td>$L \leq 5\text{mm}, 0.07\text{mm} < W \leq 0.1\text{mm}$</td> <td>4</td> </tr> <tr> <td>$L \leq 5\text{mm}, W < 0.07\text{mm}$</td> <td>*</td> </tr> </tbody> </table>	Dimension	Acceptable number	Class Of Defects	AQL Level	$W > 0.1\text{mm}, L > 5\text{mm}$	0	Minor	1.5	$L \leq 5\text{mm}, 0.07\text{mm} < W \leq 0.1\text{mm}$	4	$L \leq 5\text{mm}, W < 0.07\text{mm}$	*								
Dimension	Acceptable number	Class Of Defects	AQL Level																	
$W > 0.1\text{mm}, L > 5\text{mm}$	0	Minor	1.5																	
$L \leq 5\text{mm}, 0.07\text{mm} < W \leq 0.1\text{mm}$	4																			
$L \leq 5\text{mm}, W < 0.07\text{mm}$	*																			
L : Length W : Width * : Disregard																				
2	External Inspection (non-operating)	Dimension: Outline (Major)																		
		Bezel appearance: uneven (Minor)																		
		Scratch on the Polarize & Touch Panel : (Note:2)																		
		<table border="1"> <thead> <tr> <th>Dimension</th> <th>Acceptable number</th> <th>Class Of Defects</th> <th>AQL Level</th> </tr> </thead> <tbody> <tr> <td>$W > 0.1\text{mm}, L > 5\text{mm}$</td> <td>0</td> <td rowspan="3">Minor</td> <td rowspan="3">1.5</td> </tr> <tr> <td>$L \leq 5\text{mm}, 0.07\text{mm} < W \leq 0.1\text{mm}$</td> <td>4</td> </tr> <tr> <td>$L \leq 5\text{mm}, W < 0.07\text{mm}$</td> <td>*</td> </tr> </tbody> </table>	Dimension	Acceptable number	Class Of Defects	AQL Level	$W > 0.1\text{mm}, L > 5\text{mm}$	0	Minor	1.5	$L \leq 5\text{mm}, 0.07\text{mm} < W \leq 0.1\text{mm}$	4	$L \leq 5\text{mm}, W < 0.07\text{mm}$	*						
		Dimension	Acceptable number	Class Of Defects	AQL Level															
		$W > 0.1\text{mm}, L > 5\text{mm}$	0	Minor	1.5															
		$L \leq 5\text{mm}, 0.07\text{mm} < W \leq 0.1\text{mm}$	4																	
		$L \leq 5\text{mm}, W < 0.07\text{mm}$	*																	
		L : Length W : Width * : Disregard																		
		Dent and spots shape on the polarize (Note:2): (Note: 5)																		
<table border="1"> <thead> <tr> <th>Dimension</th> <th>Acceptable number</th> <th>Class Of Defects</th> <th>AQL Level</th> </tr> </thead> <tbody> <tr> <td>$D \leq 0.3$</td> <td>*</td> <td rowspan="3">Minor</td> <td rowspan="3">1.5</td> </tr> <tr> <td>$0.3 < D \leq 0.5$</td> <td>4</td> </tr> <tr> <td>$D > 0.5$</td> <td>0</td> </tr> </tbody> </table>	Dimension	Acceptable number	Class Of Defects	AQL Level	$D \leq 0.3$	*	Minor	1.5	$0.3 < D \leq 0.5$	4	$D > 0.5$	0								
Dimension	Acceptable number	Class Of Defects	AQL Level																	
$D \leq 0.3$	*	Minor	1.5																	
$0.3 < D \leq 0.5$	4																			
$D > 0.5$	0																			
$D = (\text{Long} + \text{Short}) / 2$ * : Disregard																				

Class of defects	Definition	
	AQL 0.65	It is a defect that is likely to result in failure or to reduce materially the usability of the product for the intended function.
	AQL 1.5	It is a defect that will not result in functioning problem with deviation classified.

Note:1.(a)Bright point defect is defined as point defect of R,G,B with area >1/2 pixel respectively

(b)Dark point defect is defined as visible in full white pattern.

(c)The point defect must under 2% ND Filter visible .

Note:2 The external inspection should be conducted at the distance 30 ± 5 cm between the eyes of inspector and the panel .

Note:3 Luminance measurement for contrast ratio is at the distance 50 ± 5 cm between the detective head and the panel with ambient luminance less than 1 lux. Contrast ratio is obtained at optimum view angle.

Note:4 W-Width in mm , L-length of Max.(L1,L2) in mm.

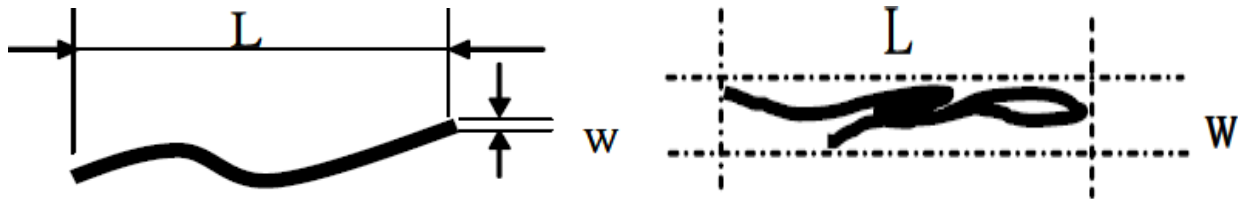

Note:5 Spot Foreign Material ($W \geq L/4$)

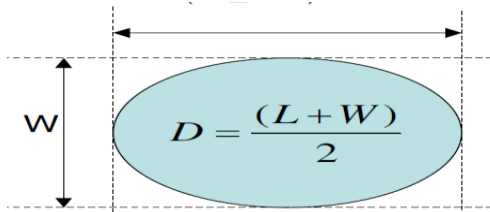

10.4 Sampling Condition

Unless otherwise agree in written, the sampling inspection shall be applied to the incoming inspection of customer.

Lot size: Quantity of shipment lot per model.

Sampling type: normal inspection, single sampling

Sampling table: ISO 2859

Inspection level: Level II

11. LCM PRODUCT LABEL DEFINE

Product Label style:

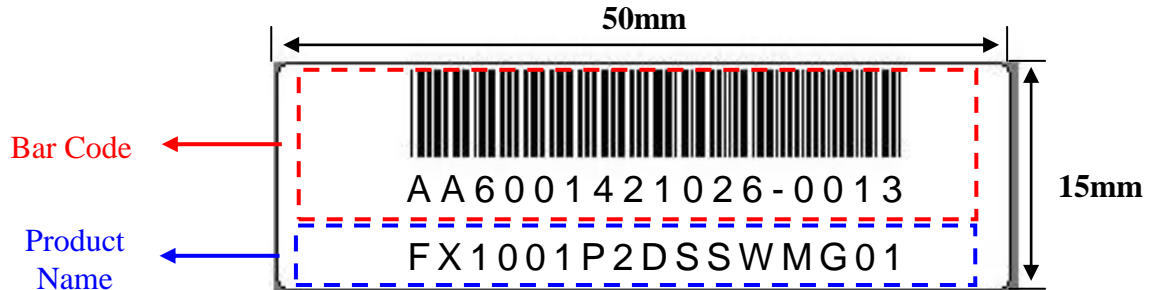

BarCode Define:

A A 6 0014 2 10 26-0013

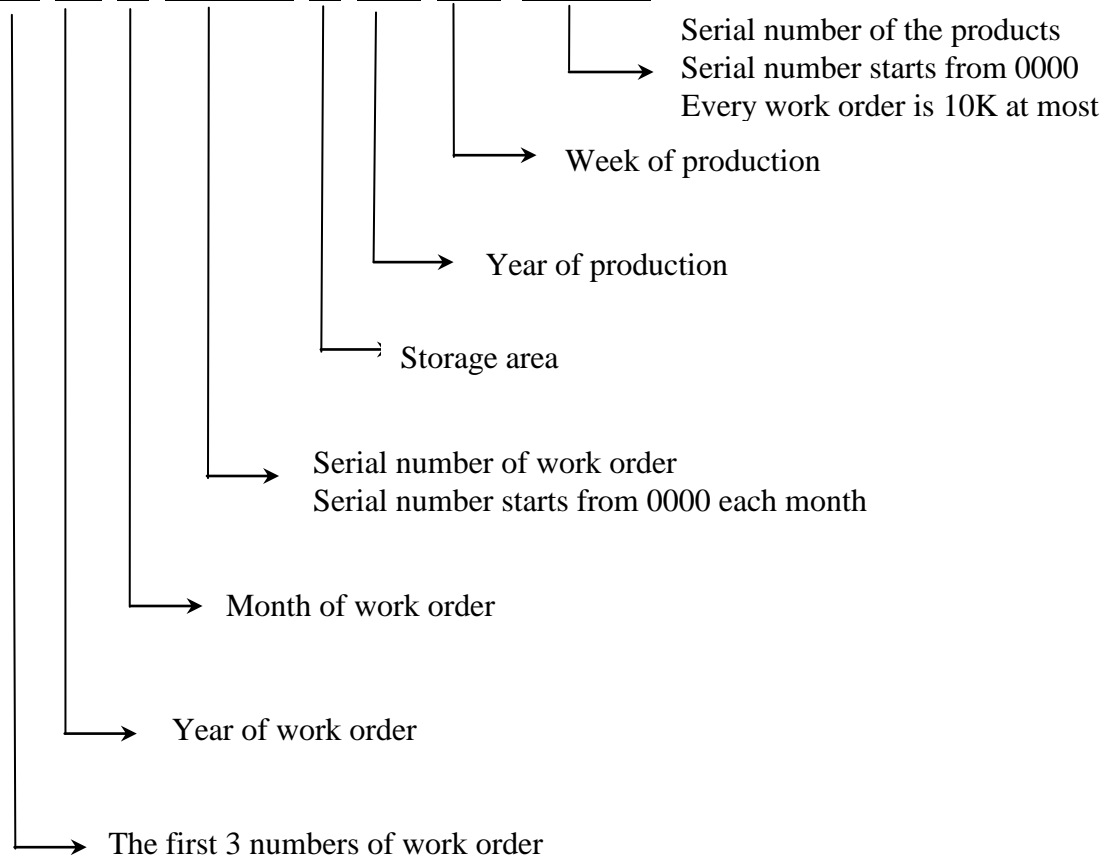

Product Name Define:

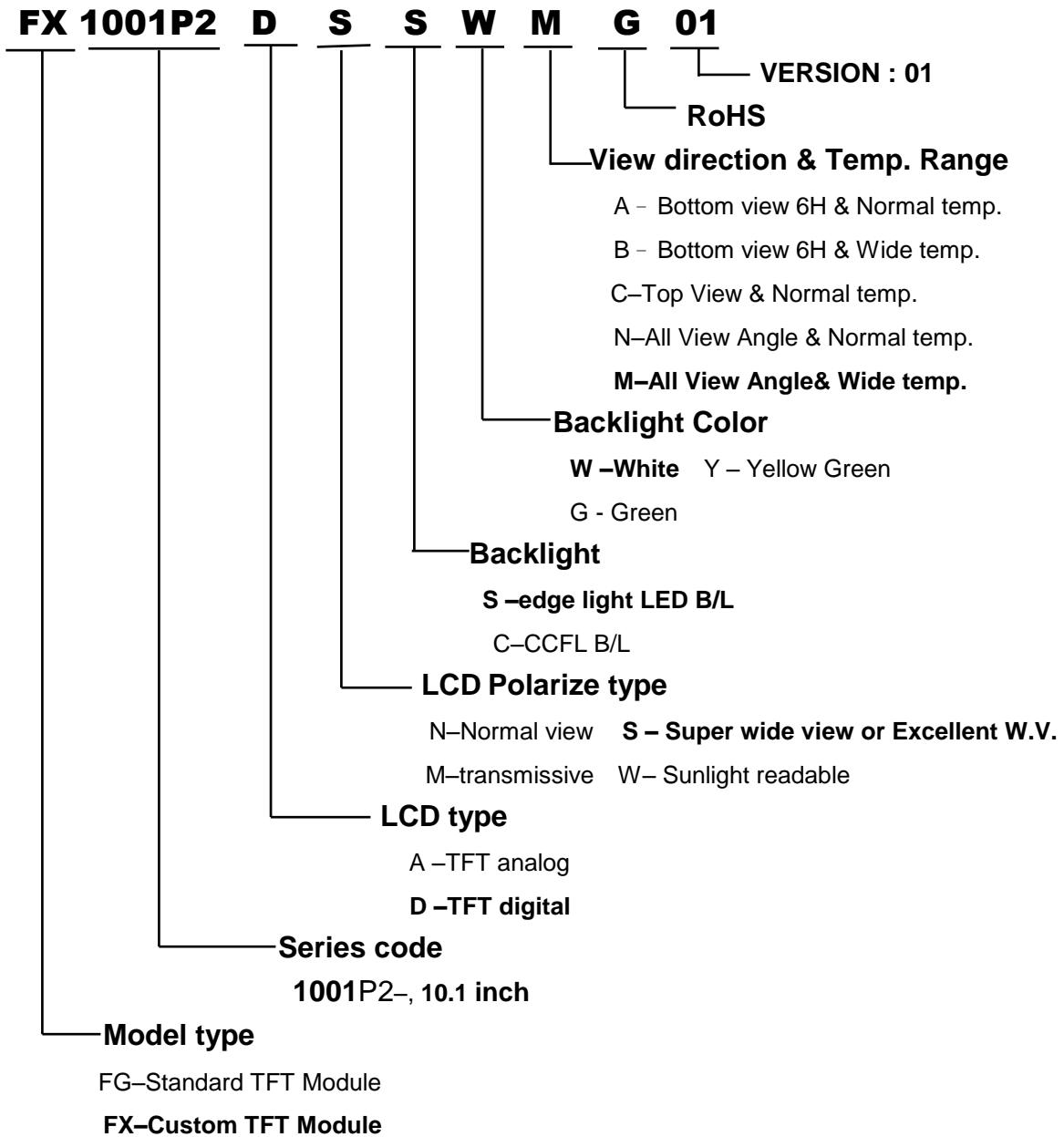

12. PRECAUTIONS IN USE LCM

1. ASSEMBLY PRECAUTIONS

- (1) You must mount a module using holes arranged in four corners or four sides.
- (2) You should consider the mounting structure so that uneven force (ex. Twisted stress) is not applied to the module. And the case on which a module is mounted should have sufficient strength so that external force is not transmitted directly to the module.
- (3) Do not touch, push or rub the exposed polarizers with glass, tweezers or anything harder than HB pencil lead. And please do not rub with dust clothes with chemical treatment.
- (4) Wipe off saliva or water drops as soon as possible. Their long time contact with polarizer causes deformations and color fading.
- (5) Do not open the case because inside circuits do not have sufficient strength.
- (6) Please do not take a LCD module to pieces and reconstruct it. Resolving and reconstructing modules may cause them not to work well.
- (7) Please do not touch metal frames with bare hands and soiled gloves. A color change of the metal frames can happen during a long preservation of soiled LCD modules.
- (8) Please pay attention to handling lead wire of backlight so that it is not tugged in connecting with inverter.

2. OPERATING PRECAUTIONS

- (1) Please be sure to turn off the power supply before connecting and disconnecting signal input cable.
- (2) Please do not change variable resistance settings in LCD module. They are adjusted to the most suitable value. If they are changed, it might happen LCD does not satisfy the characteristics specification
- (3) Be careful for condensation at sudden temperature change. Condensation makes damage to polarizer or electrical contacted parts. And after fading condensation, smear or spot will occur.
- (4) When fixed patterns are displayed for a long time, remnant image is likely to occur.
- (5) Module has high frequency circuits. Sufficient suppression to the electromagnetic interference shall be done by system manufacturers. Grounding and shielding methods may be important to minimize the interference.
- (6) Please consider that LCD backlight takes longer time to become stable of radiation characteristics in low temperature than in room temperature.

3. ELECTROSTATIC DISCHARGE CONTROL

- (1) The operator should be grounded whenever he/she comes into contact with the module. Never touch any of the conductive parts such the copper leads on the PCB and the interface terminals with any

parts of the human body.

- (2) The modules should be kept in antistatic bags or other containers resistant to static for storage.
- (3) Only properly grounded soldering irons should be used.
- (4) If an electric screwdriver is used, it should be well grounded and shielded from commutator sparks.
- (5) The normal static prevention measures should be observed for work clothes and working benches; for the latter conductive (rubber) mat is recommended
- (6) Since dry air is inductive to statics, a relative humidity of 50-60% is recommended.

4. STORAGE PRECAUTIONS

- (1) When you store LCDs for a long time, it is recommended to keep the temperature between 0°C-40°C without the exposure of sunlight and to keep the humidity less than 90%RH.
- (2) Please do not leave the LCDs in the environment of high humidity and high temperature such as 60°C 90%RH
- (3) Please do not leave the LCDs in the environment of low temperature; below -20°C.

5. OTHERS

- (1) A strong incident light into LCD panel might cause display characteristics' changing inferior because of polarizer film, color filter, and other materials becoming inferior. Please do not expose LCD module direct sunlight and strong UV rays
- (2) Please pay attention to a panel side of LCD module not to contact with other materials in preserving it alone.
- (3) For the packaging box, please pay attention to the followings:
 - a. Please do not pile them up more than 5 boxes. (They are not designed so.) And please do not turn over.
 - b. Please handle packaging box with care not to give them sudden shock and vibrations. And also please do not throw them up.
 - c. Packing box and inner case for LCDs are made of cardboard. So please pay attention not to get them wet. (Such like keeping them in high humidity or wet place can occur getting them wet.)

6. LIMITED WARRANTY

Unless otherwise agreed between DATA IMAGE and customer, DATA IMAGE will replace or repair any of its LCD and LCM which is found to be defective electrically and visually when inspected in accordance with DATA IMAGE acceptance standards, for a period on one year from date of shipment. Confirmation of such date shall be based on freight documents. The warranty liability of DATA IMAGE is limited to repair and/or replacement on the terms set forth above. DATA IMAGE will not responsible for any subsequent or consequential events.

Confidential Document
13. OUTLINE DRAWING

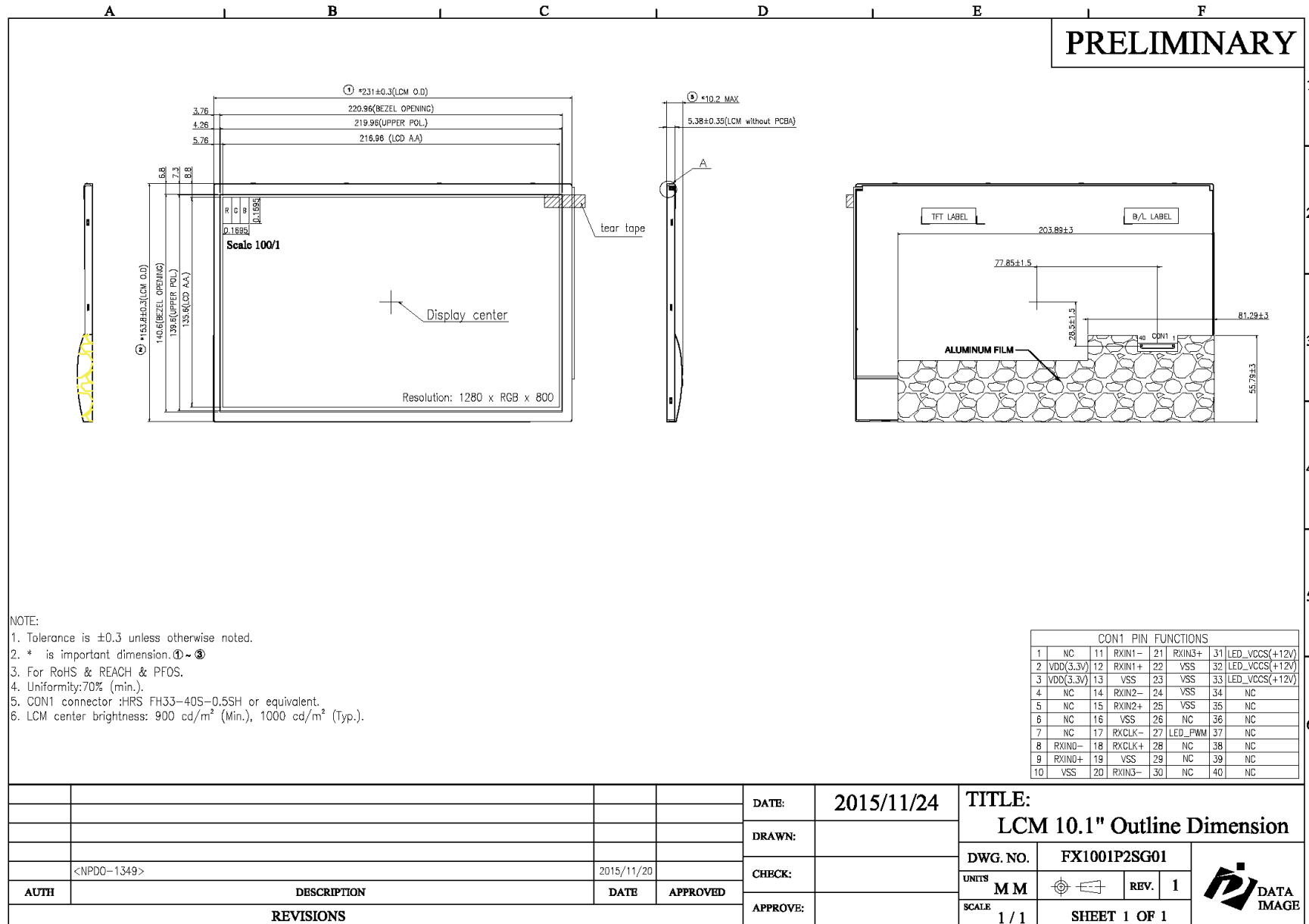

14. PACKAGE INFORMATION

TBD