

# TFT-DISPLAY DATASHEET

## DATA IMAGE

Model: FX1001P1DSSWMG01

### BRIEF SPEC.:

Main Feature	Landscape Normally Black Wide Viewing Angle
Active Screen Area	216.96 x 135.6 [mm]
Diagonal   Format	10.1"   16:10
Resolution	1280 X 800
Colors	8 Bit
Backlight	Black
Brightness	500 cd/m <sup>2</sup>
LED Life Time	50K(h)
Interface	LVDS
Viewing Angle	85/85 L/R 85/85
Touchscreen	no
Power Supply	3.3V (Typ.)
Module Outline	231 x 153.8 x 9.84 [mm]
Operation Temperature	-20 ... +70 °C
Storage Temperature	-30... +80 °C
Surface Treatment	Glare Hard Coating



# DATA IMAGE CORPORATION

## TFT Module Specification Preliminary

ITEM NO.: FX1001P1DSSWMG01

### Table of Contents

- 1. COVER & CONTENTS ..... 1
- 2. RECORD OF REVISION ..... 2
- 3. GENERAL SPECIFICATIONS ..... 3
- 4. ABSOLUTE MAXIMUM RATINGS ..... 3
- 5. ELECTRICAL CHARACTERISTICS ..... 3
- 6. PIXEL FORMAT IMAGE ..... 4
- 7. INPUT SIGNAL CHARACTERISTICS ..... 4
- 8. OPTICAL CHARACTERISTIC ..... 7
- 9. BLOCK DIAGRAM ..... 9
- 10. PIN CONNECTIONS ..... 10
- 11. QUALITY ASSURANCE ..... 13
- 12. LCM PRODUCT LABEL DEFINE..... 17
- 13. PRECAUTIONS IN USE LCM ..... 19
- 14. OUTLINE DRAWING ..... 20
- 15. PACKAGE INFORMATION..... 21

Customer Companies	QA Approval	QA Check	R&D Approval	R&D Check
	<i>pretty</i>	<i>Seven</i>	<i>Gromer</i>	<i>Shone</i>
Approved by	Version:	Issued Date:	Sheet Code:	Total Pages:
	4	18/JAN/16'		21

**2. RECORD OF REVISION**

Rev	Date	Item	Page	Comment	Source
1	07/NOV/15'			Initial preliminary	ESR S1510013
2	25/NOV/15'	14	20	Modify OUTLINE DRAWING from Rev 1 to 2.	11S-FB0010
3	14/DEC/15'	5.1	3	Modify Power Supply Current for LED.	11S-FC0005
4	18/JAN/16'	5.1	3	Add LED life time	110-FC0029
		11.2.4	15	Modify Inspection condition	110-G10016
		14	20	Modify OUTLINE DRAWING from Rev 2 to 3.	

### 3. GENERAL SPECIFICATIONS

Parameter	Specifications	Unit
Screen Size	10.1 (diagonal)	inch
Display Format	1280(H) x (R,G,B) x 800(V)	dot
Active Area	216.96(W) x 135.60(H)	mm
Pixel Pitch	0.1695(W) x 0.1695(H)	mm
Pixel Configuration	RGB-Stripe	
Outline Dimension	231 (W) x153.8 (H) x9.84 (D)	mm
Surface treatment	Glare , Hard -Coating	
Interface	LVDS	
Weight	TBD	g
Display mode	Normally Black, Transmissive	
Our components and processes are compliant to RoHS standard		

### 4. ABSOLUTE MAXIMUM RATINGS

(Note 1)

Parameter	Symbol	MIN.	MAX.	Unit	Remark
Power voltage	V <sub>DD</sub>	-0.3	5	V	
Operating temperature	T <sub>OP</sub>	-20	70	°C	
Storage temperature	T <sub>ST</sub>	-30	80	°C	

Note 1: The absolute maximum rating values of this product are not allowed to be exceeded at any times. Should a module be used with any of the absolute maximum ratings exceeded, the characteristics of the module may not be recovered, or in an extreme case, the module may be permanently destroyed.

### 5. ELECTRICAL CHARACTERISTICS

#### 5.1 Typical Operation Conditions

Parameter	Symbol	MIN.	TYP.	MAX.	Unit	Remark
Power voltage	V <sub>DD</sub>	2.5	3.3	3.6	V	Note 1
Power Supply Voltage for LED	V <sub>IN</sub>	-	12	-	V	
Power Supply Current for LED	I <sub>VIN</sub>	-	390	460	mA	
Input logic high voltage	V <sub>IH</sub>	0.8V <sub>DD</sub>	-	3.6	V	Note 1
Input logic low voltage	V <sub>IL</sub>	0	-	0.2 V <sub>DD</sub>	V	
Input signal Voltage	BLBRT	0.3	-	V <sub>IN</sub>		
	BLEN	0.3	-	V <sub>IN</sub>		
LED life time		50,000	-	-	hr	

Note 1: V<sub>DD</sub> setting should match the signals output voltage of customer's system board.

## 6. Pixel Format Image

Figure 3 shows the relationship of the input signals and LCD pixel format image

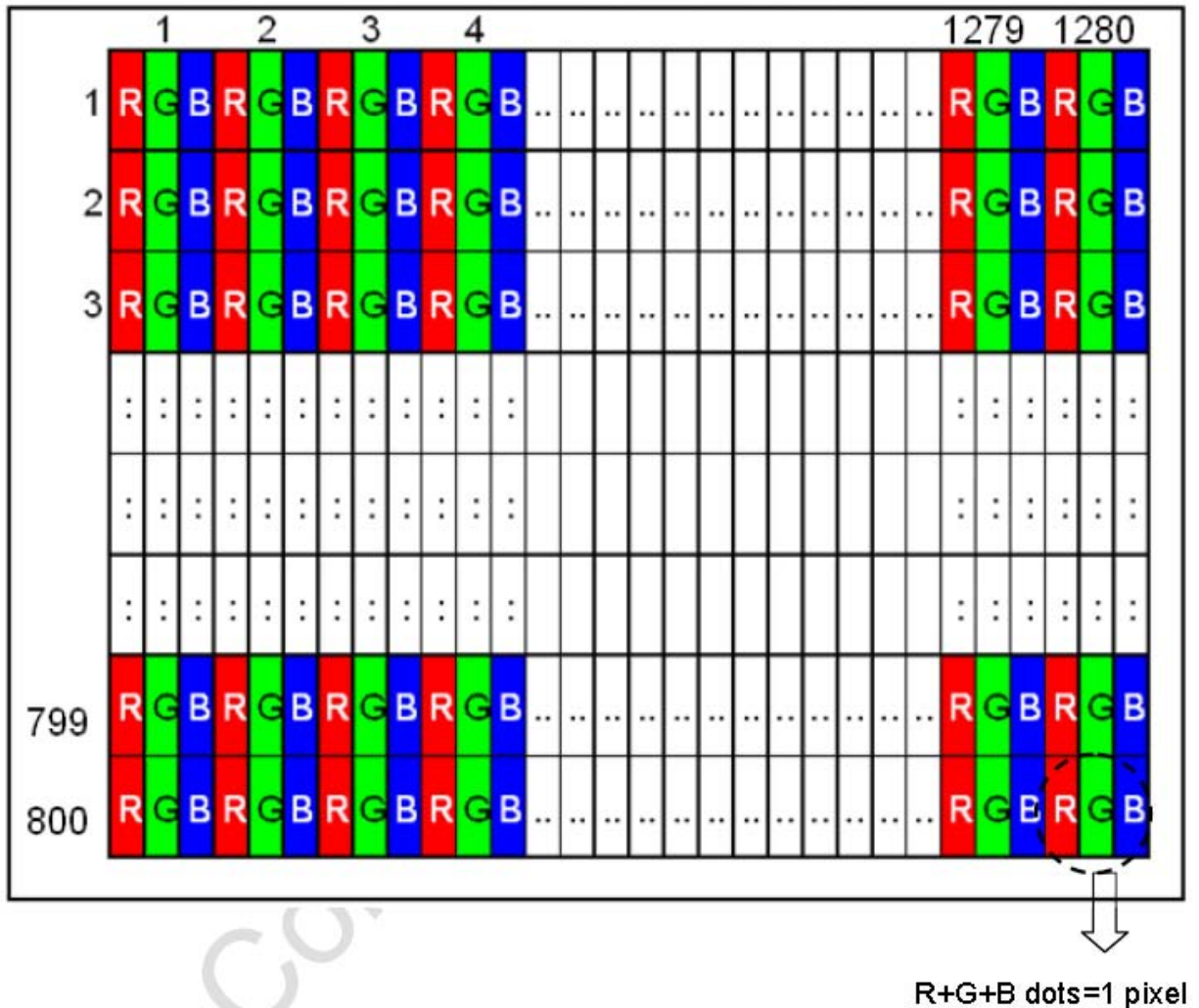

Figure 3 Pixel Format

## 7. INPUT SIGNAL CHARACTERISTICS

### 7.1 LVDS Receiver

Parameter	Symbol	MIN.	TYP.	MAX.	Unit	Remark
Differential input high Threshold voltage	RxVTH	-	-	+100	mV	V <sub>CM</sub> =1.2V
Differential input low Threshold voltage	RxVTL	-100	-	-	mV	
Common Mode Voltage	V <sub>CM</sub>	0.3+(VID/2)	-	VDD-1.2-(VID/2)	V	
Common Mode Voltage	ΔV <sub>CM</sub>	-	-	50	mV	V <sub>CM</sub> =1.2V
Differential voltage	VID	200	-	400	mV	

Note : Input signals shall be low or Hi-Z state when VDD is off.

(2) All electrical characteristics for LVDS signal are defined and shall be measured at the interface connector of LCD.

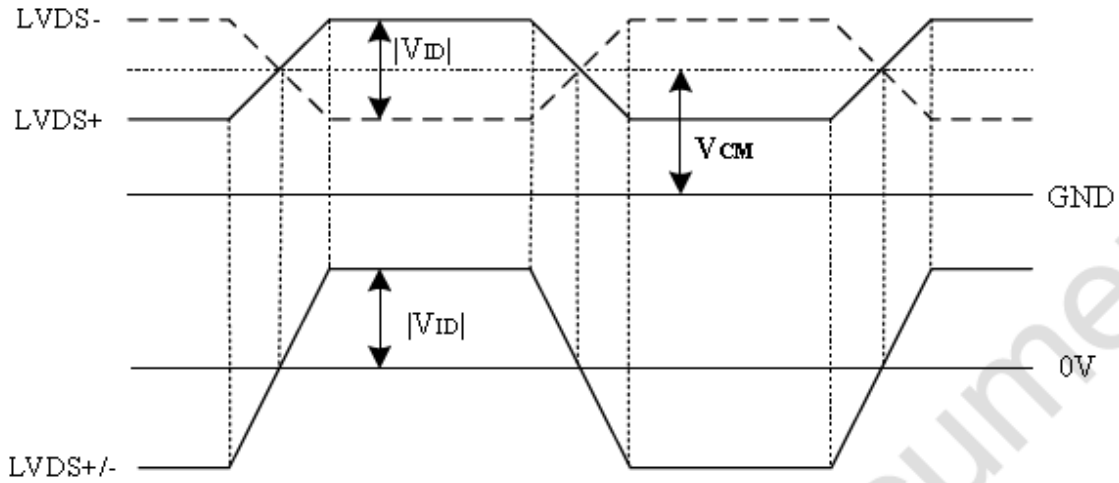
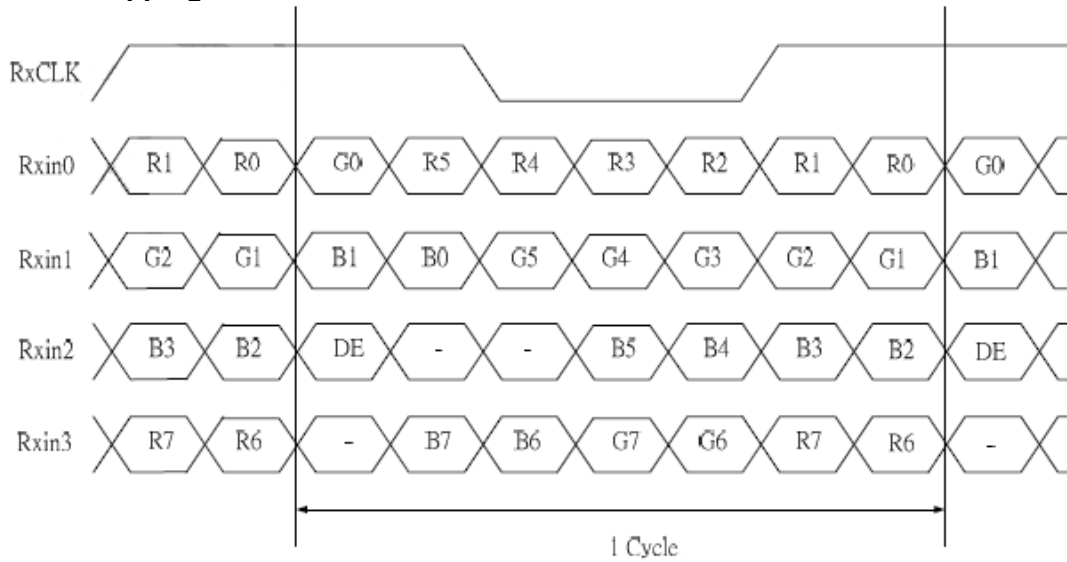
**Voltage Definitions**

**LVDS Data Mapping**

### 7.2 Interface Timings

Parameter	Symbol	MIN.	TYP.	MAX.	Unit	Remark
Frame Rate	-	-	60	-	Hz	
Frame Period	$t_v$	815	823	1023	line	
Vertical display area	$t_{vd}$	800			line	
Vertical Blanking Time	$t_{vw}+t_{vbp}+t_{vfp}$	15	23	33	line	
1 Line Scanning Time	$t_H$	1410	1440	1470	clock	
Horizontal Display Time	$t_{HD}$	1280			clock	
Horizontal Blanking Time	$t_{HW}+t_{HBP}+t_{HFP}$	60	160	190	clock	
Clock Rate	$1/T_C$	68.9	71.1	73.4	MHz	

### 7.3 Timing Diagram of Interface Signal (DE mode)

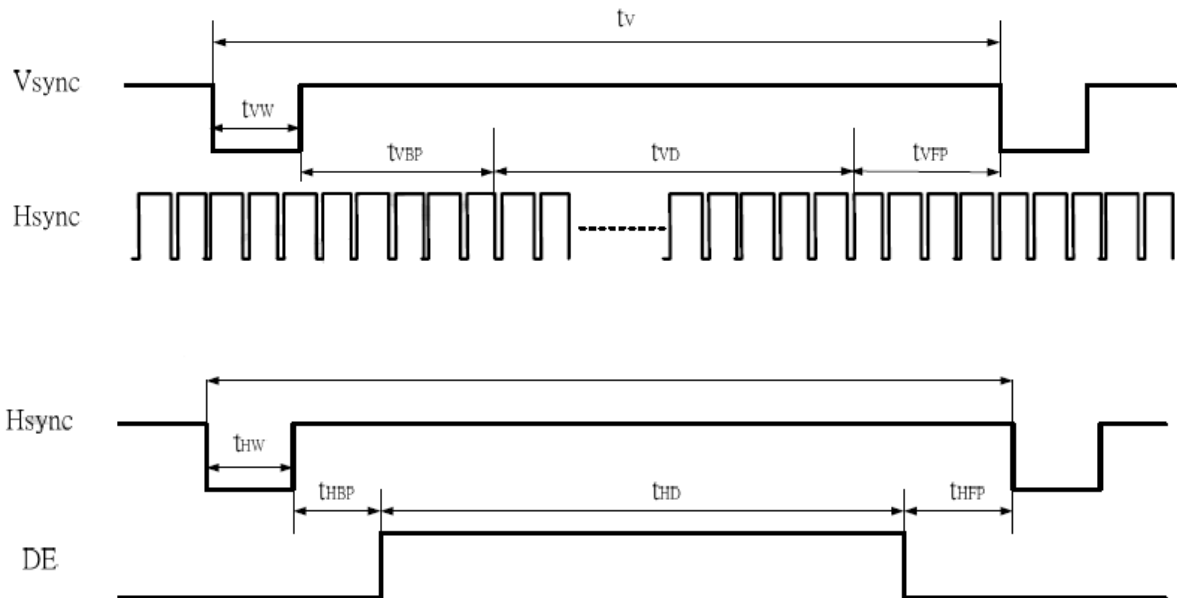
Timing Characteristics



### 8. OPTICAL CHARACTERISTIC

Parameter	Symbol	Condition	MIN.	TYP.	MAX.	Unit	Remarks	
Viewing Angle (CR≥10)	$\theta_L$	$\Phi=180^\circ$ (9 o'clock)	75	85	-	deg	Note 1	
	$\theta_R$	$\Phi=0^\circ$ (3 o'clock)	75	85	-			
	$\theta_T$	$\Phi=90^\circ$ (12 o'clock)	75	85	-			
	$\theta_B$	$\Phi=270^\circ$ (6 o'clock)	75	85	-			
Contrast Ratio	CR	Normal $\theta=\Phi=0^\circ$	600	800	-		Note 4	
Response time	Rising +Falling		-	25	50	ms	Note 3	
Color chromaticity	Rx		Normal $\theta=\Phi=0^\circ$	Typ. -0.03	0.561	Typ. +0.03	-	Note 2,5,6
	Ry				0.334		-	
	Gx				0.341		-	
	Gy				0.568		-	
	Bx				0.161		-	
	By				0.129		-	
	Wx	Typ. -0.05		0.313	Typ. +0.05	-		
Wy	0.329	-						
Luminance	L	400	500	-	cd/m <sup>2</sup>	Note 6		
Luminance uniformity	Yu	70	75	-	%	Note 7		

Test Conditions:

- VDD=3.3V, LED\_VCCS=12V (Backlight current), the ambient temperature is 25°C.
- The test systems refer to Note 2.

Note 1: Definition of viewing angle range

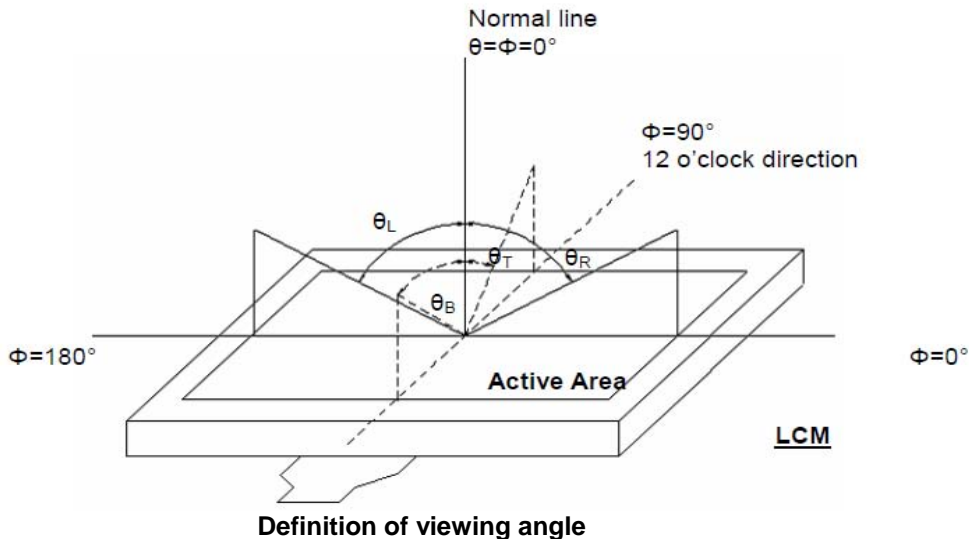

Note 2: Definition of optical measurement system.

The optical characteristics should be measured in dark room. After 30 minutes operation, the optical properties are measured at the center point of the LCD screen. (Viewing angle is measured by ELDIM-EZ contrast/Height :1.2mm, Response time is measured by Photo detector TOPCON BM-7, other items are measured by BM-5A/ Field of view: 1° /Height: 500mm.)

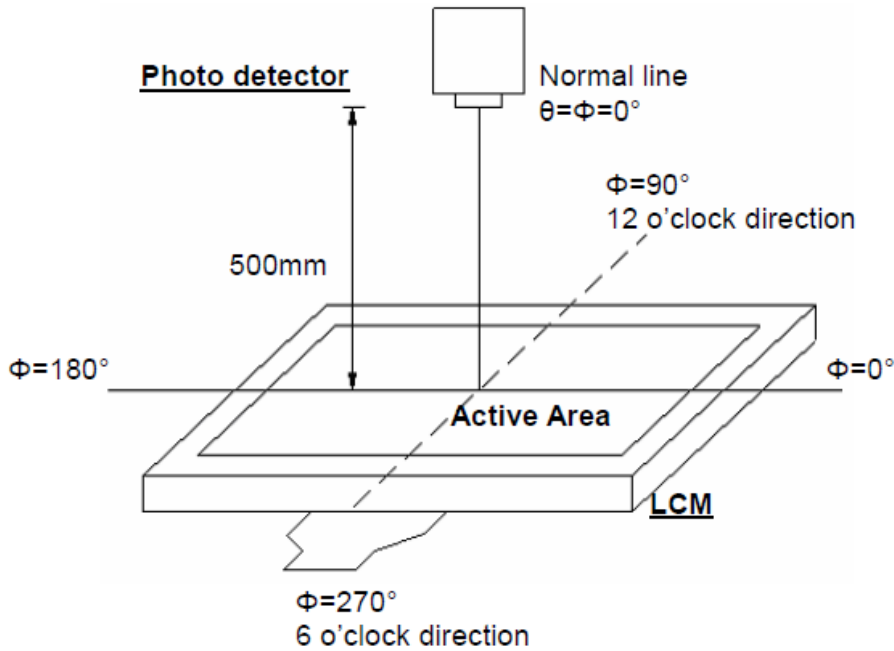

**Optical measurement system setup**

Note 3: Definition of Response time

The response time is defined as the LCD optical switching time interval between "White" state and "Black" state. Rise time ( $T_{ON}$ ) is the time between photo detector output intensity changed from 90% to 10%. And fall time ( $T_{OFF}$ ) is the time between photo detector output intensity changed from 10% to 90%.

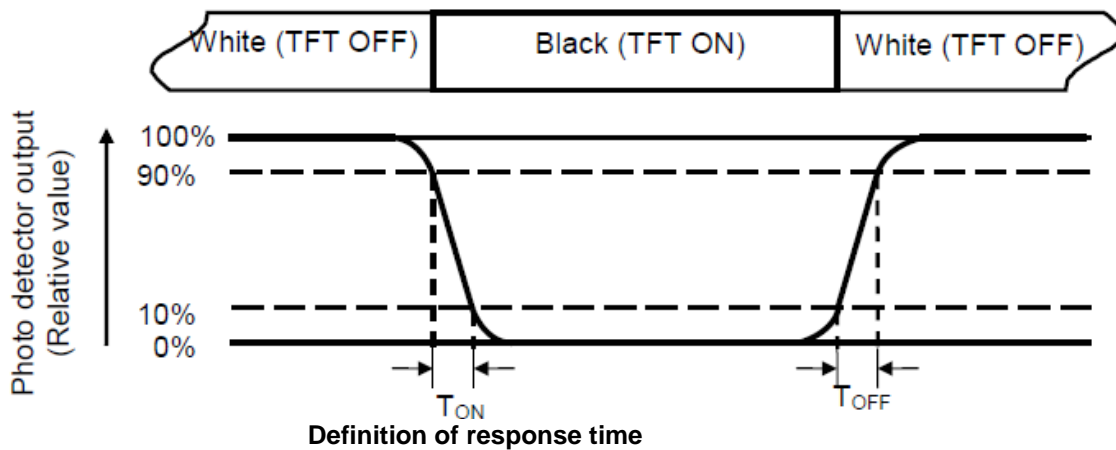

Note 4: Definition of contrast ratio

$$\text{Contrast ratio (CR)} = \frac{\text{Luminance measured when LCD on the "White" state}}{\text{Luminance measured when LCD on the "Black" state}}$$

Note 5: Definition of color chromaticity (CIE1931)  
Color coordinates measured at center point of LCD.

Note 6: Measuring the center area of the panel. The LED driving condition is LED\_VCCS=12V

Note 7: Definition of Luminance Uniformity

Active area is divided into 9 measuring areas. Every measuring point is placed at the center of each measuring area.

$$\text{Luminance Uniformity (Yu)} = \frac{B_{min}}{B_{max}}$$

L-----Active area length      W----- Active area width

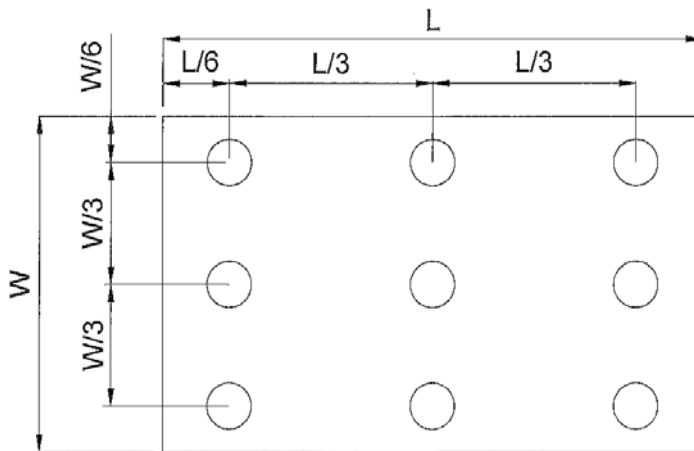

## 9. BLOCK DIAGRAM

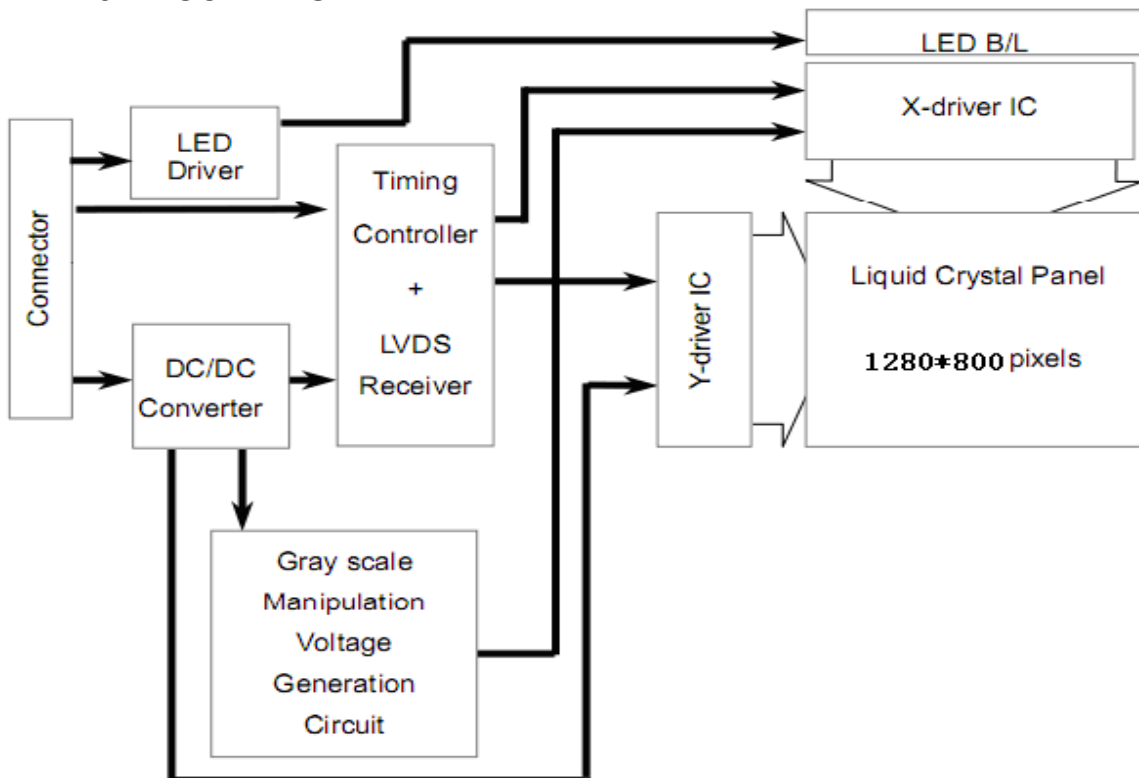

## 10. PIN CONNECTIONS

### 10.1 CN1 FUNCTIONS

Pin No	Symbol	Function
1	NC	No connection
2	BIST	BIST pin
3	RXIN3+	LVDS receiver signal CH3(+)
4	RXIN3-	LVDS receiver signal CH3(-)
5	GND	Ground
6	CK IN+	LVDS receiver signal CK(+)
7	CK IN-	LVDS receiver signal CK(-)
8	GND	Ground
9	RXIN2+	LVDS receiver signal CH2(+)
10	RXIN2-	LVDS receiver signal CH2(-)
11	GND	Ground
12	RXIN1+	LVDS receiver signal CH1(+)
13	RXIN1-	LVDS receiver signal CH1(-)
14	GND	Ground
15	RXIN0+	LVDS receiver signal CH0(+)
16	RXIN0-	LVDS receiver signal CH0(-)
17	GND	Ground
18	NC	No connection
19	VDD	power supply
20	VDD	power supply

**10.2 CN2 FUNCTIONS**

Pin No	Symbol	Function
1	GND	Ground
2	BLBRT	PWM signal(Brightness adjustment)
3	BLEN	ON/OFF terminal voltage
4	GND	Ground
5	VIN	+12V power supply
6	VIN	+12V power supply
7	VIN	+12V power supply
8	GND	Ground

BLBRT: The frequency must be in the range of 100Hz to 22 kHz

BLEN: High = IC is enabled; low = IC is disabled.

Note: BLBRT is used to adjust backlight brightness.

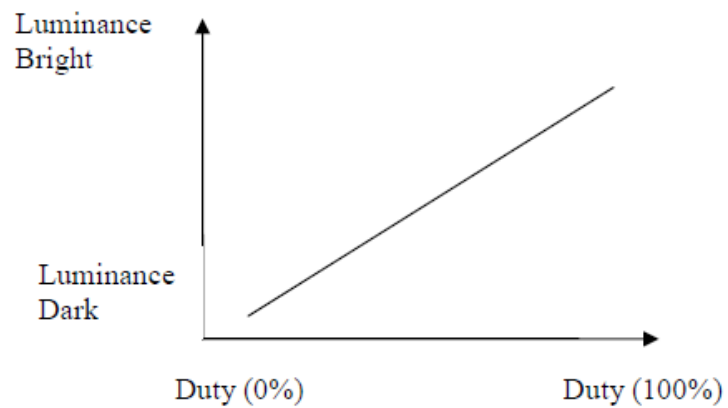

**Power ON/OFF Sequence**

Power on/off sequence is as follows. Interface signals are also shown in the chart. Signals from any system shall be Hi-Z state or low level when VDD is off.

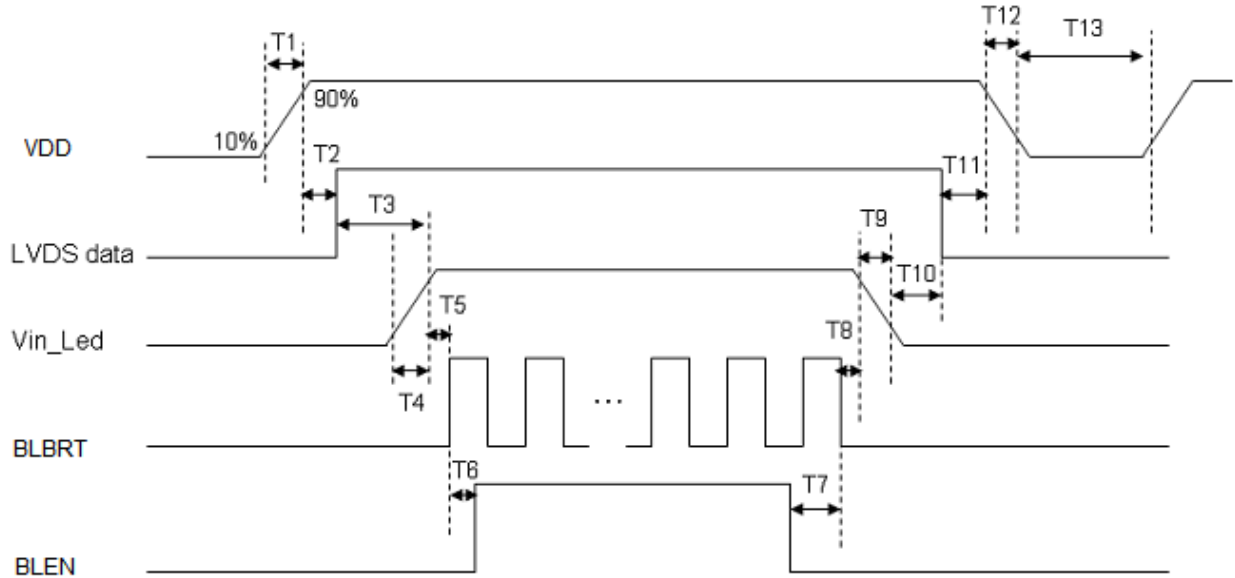

**Figure 9-3 Power Sequence**

**10.3.1 Power Sequencing Requirements**

Parameter	Symbol	min	Typ.	max	Unit
VDD Rise Time	T1	0.5	--	10	ms
VDD Good to Signal Valid	T2	30	--	90	ms
Signal Valid to Backlight On	T3	200	--	--	ms
Backlight Power on Time	T4	0.5	--	--	ms
Backlight VIN Good to System PWM on	T5	10	--	--	ms
System PWM on to Backlight Enable on	T6	10	--	--	ms
Backlight Enable off to System PWM off	T7	0	--	--	ms
System PWM off to B/L Power Disable	T8	10	--	--	ms
Backlight Power off Time	T9	0.5	10	30	
Backlight Off to Signal Disable	T10	200	--	--	ms
Signal Disable to Power Down	T11	0	--	50	ms
VDD Fall Time	T12	0.5	10	30	ms
Power Off	T13	500	--	--	ms

## 11. QUALITY ASSURANCE

### 11.1. Test Conditions

#### 11.1.1 Temperature and Humidity(Ambient Temperature)

Temperature :  $25 \pm 5^{\circ}\text{C}$   
 Humidity :  $65 \pm 5\%$

#### 11.1.2 Operation

Unless specified otherwise, test will be conducted under function state.

#### 11.1.3 Container

Unless specified otherwise, vibration test will be conducted to the product itself without putting it in a container.

#### 11.1.4 Test Frequency

In case of related to deterioration such as shock test. It will be conducted only once.

#### 11.1.5 Test Method

No.	Item	Test Conditions	Remark
1	High Temperature Storage Test	Ta=80°C, 240hrs	IEC68-2-2
2	Low Temperature Storage Test	Ta=-30°C, 240hrs	IEC68-2-1
3	High Temperature Operation Test	Ts=70°C, 240hrs	IEC68-2-2
4	Low Temperature Operation Test	Ta=-20°C, 240hrs	IEC68-2-1
5	High Temperature and High Humidity Operation Test	T=60°C, 90%RH, 240hrs	IEC68-2-3
6	Thermal cycling storage test	-30°C ----25°C -----80°C ,200Cycle 30min 5min 30min	IEC68-2-14
7	vibration test	Frequency:10~55HZ Amplitude:1.5mm Sweep time:11min Test period:6Cycles for each direction of X,Y,Z	IEC68-2-6
8	Drop test	Height :60cm 1 conner,3edges,6surfaces	IEC68-2-32
9	Shock test	100G,6ms,Direction:±X±Y±Z Cycle:3times	IEC68-2-27
10	ESD test	Location: LCM/TP surface Condition:150pf 330Ω Contact +/- 8kV Air +/-15kV Criteria: Class C	IEC61000-4-2

Note 1: Ta is the ambient temperature of samples.

Note 2: Ts is the temperature of panel's surface.

Note 3: In the standard condition, there shall be no practical problem that may affect the display function. After the reliability test, the product only guarantees operation, but don't guarantee all of the cosmetic specification.

Note 4: Before cosmetic and function test, the product must have enough recovery time, at least 2 hours at room temperature.

## 11.2 Inspection condition

### 11.2.1 Inspection conditions

11.2.1.1 Inspection Distance :  $35 \pm 5$  cm

11.2.1.2 View Angle :

- (1) Inspection under operating condition :  $\pm 5^\circ$
- (2) Inspection under non-operating condition :  $\pm 45^\circ$

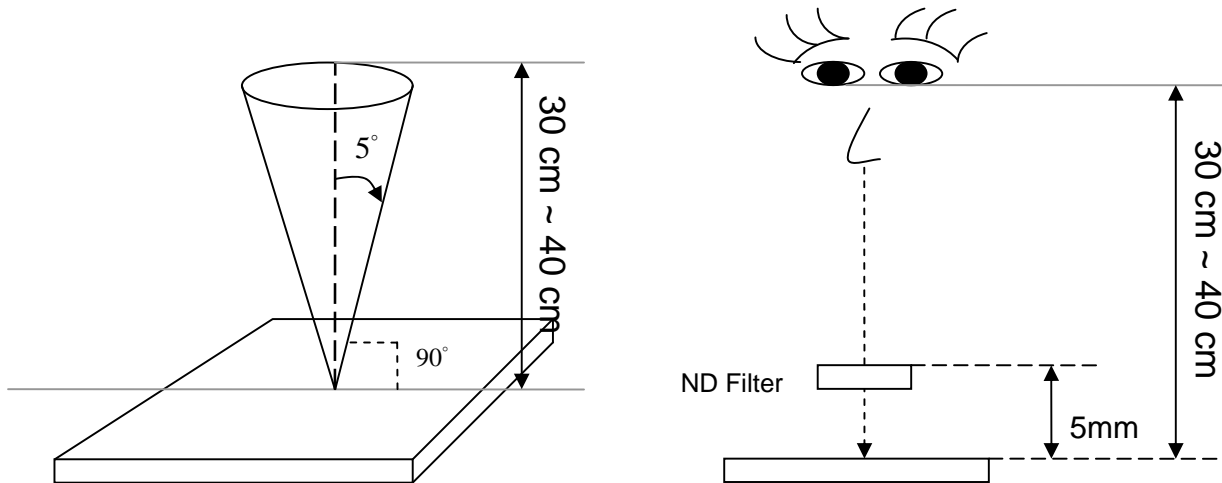

### 11.2.2 Environment conditions :

Ambient Temperature :		$25 \pm 5^\circ\text{C}$
Ambient Humidity :		$65 \pm 5\%$
Ambient Illumination	Cosmetic Inspection	400 ~ 600lux
	Functional Inspection	300 ~ 500lux

### 11.2.3 Definition of applicable Zones

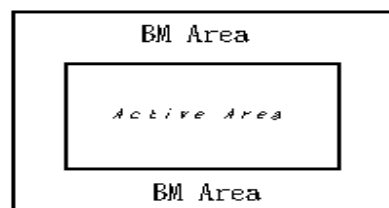

## 11.2.4 Inspection Parameters

No.	Parameter	Criteria														
1	Operating	Display function: No Display malfunction (Major)														
		Line Defect: No obvious Vertical and Horizontal line defect in bright, dark and colored.														
		Point Defect: Active area $\leq 6$ dots (Minor) (Note:1)														
		<table border="1"> <thead> <tr> <th rowspan="2">Item</th> <th>Acceptable number</th> <th rowspan="2">Total</th> </tr> <tr> <th>Active Area</th> </tr> </thead> <tbody> <tr> <td rowspan="2">Bright</td> <td>Random</td> <td>3</td> </tr> <tr> <td>Two dots adjacent</td> <td>1</td> </tr> <tr> <td rowspan="2">Dark</td> <td>Random</td> <td>4</td> </tr> <tr> <td>Two dots adjacent</td> <td>2</td> </tr> </tbody> </table>	Item	Acceptable number	Total	Active Area	Bright	Random	3	Two dots adjacent	1	Dark	Random	4	Two dots adjacent	2
		Item		Acceptable number		Total										
			Active Area													
Bright	Random	3														
	Two dots adjacent	1														
Dark	Random	4														
	Two dots adjacent	2														
Non-uniformity: Visible through 2%ND filter White , R , G ,B and gray 50% pattern.																
Foreign material in Black or White spots shape ( $W > 1/4L$ )																
<table border="1"> <thead> <tr> <th>Zone</th> <th>Acceptable number</th> <th>Class of Defects</th> </tr> </thead> <tbody> <tr> <td>Dimension <math>D &gt; 0.5</math></td> <td>0</td> <td rowspan="3">Minor</td> </tr> <tr> <td><math>0.3 &lt; D \leq 0.5</math></td> <td>5</td> </tr> <tr> <td><math>0.3 \leq D</math></td> <td>*</td> </tr> </tbody> </table> <p style="text-align: center;"><math>D = (\text{Long} + \text{Short}) / 2</math>      *: Disregard</p>	Zone	Acceptable number	Class of Defects	Dimension $D > 0.5$	0	Minor	$0.3 < D \leq 0.5$	5	$0.3 \leq D$	*						
Zone	Acceptable number	Class of Defects														
Dimension $D > 0.5$	0	Minor														
$0.3 < D \leq 0.5$	5															
$0.3 \leq D$	*															
Foreign Material in Line or spiral shape ( $W \leq 1/4L$ ) (Note: 4)																
<table border="1"> <thead> <tr> <th>Zone</th> <th>Zone</th> <th>Acceptable number</th> <th>Class of Defects</th> </tr> </thead> <tbody> <tr> <td>L (mm) <math>L &gt; 10</math></td> <td>W(mm) <math>W &gt; 0.1</math></td> <td>0</td> <td rowspan="3">Minor</td> </tr> <tr> <td><math>L \leq 10</math></td> <td><math>0.07 &lt; W \leq 0.1</math></td> <td>5</td> </tr> <tr> <td><math>L \leq 10</math></td> <td><math>W \leq 0.07</math></td> <td>*</td> </tr> </tbody> </table> <p style="text-align: center;">L : Length    W : Width      *: Disregard</p>	Zone	Zone	Acceptable number	Class of Defects	L (mm) $L > 10$	W(mm) $W > 0.1$	0	Minor	$L \leq 10$	$0.07 < W \leq 0.1$	5	$L \leq 10$	$W \leq 0.07$	*		
Zone	Zone	Acceptable number	Class of Defects													
L (mm) $L > 10$	W(mm) $W > 0.1$	0	Minor													
$L \leq 10$	$0.07 < W \leq 0.1$	5														
$L \leq 10$	$W \leq 0.07$	*														
2	External Inspection (non-operating)	Dimension: Outline (Major)														
		Bezel appearance: uneven (Minor)														
		Scratch on the polarize: (Note:2)														
		<table border="1"> <thead> <tr> <th>Zone</th> <th>Zone</th> <th>Acceptable number</th> <th>Class of Defects</th> </tr> </thead> <tbody> <tr> <td>L (mm) <math>L &gt; 10</math></td> <td>W(mm) <math>W &gt; 0.1</math></td> <td>0</td> <td rowspan="3">Minor</td> </tr> <tr> <td><math>L \leq 10</math></td> <td><math>0.05 &lt; W \leq 0.1</math></td> <td>5</td> </tr> <tr> <td><math>L \leq 10</math></td> <td><math>W \leq 0.05</math></td> <td>*</td> </tr> </tbody> </table> <p style="text-align: center;">L : Length    W : Width      *: Disregard</p>	Zone	Zone	Acceptable number	Class of Defects	L (mm) $L > 10$	W(mm) $W > 0.1$	0	Minor	$L \leq 10$	$0.05 < W \leq 0.1$	5	$L \leq 10$	$W \leq 0.05$	*
		Zone	Zone	Acceptable number	Class of Defects											
L (mm) $L > 10$	W(mm) $W > 0.1$	0	Minor													
$L \leq 10$	$0.05 < W \leq 0.1$	5														
$L \leq 10$	$W \leq 0.05$	*														
Dent or bubble on the polarize (Note:2)																
<table border="1"> <thead> <tr> <th>Zone</th> <th>Acceptable number</th> <th>Class of Defects</th> </tr> </thead> <tbody> <tr> <td>Dimension <math>D &gt; 0.5</math></td> <td>0</td> <td rowspan="3">Minor</td> </tr> <tr> <td><math>0.3 &lt; D \leq 0.5</math></td> <td>5</td> </tr> <tr> <td><math>0.3 \leq D</math></td> <td>*</td> </tr> </tbody> </table> <p style="text-align: center;"><math>D = (\text{Long} + \text{Short}) / 2</math>      *: Disregard</p>	Zone	Acceptable number	Class of Defects	Dimension $D > 0.5$	0	Minor	$0.3 < D \leq 0.5$	5	$0.3 \leq D$	*						
Zone	Acceptable number	Class of Defects														
Dimension $D > 0.5$	0	Minor														
$0.3 < D \leq 0.5$	5															
$0.3 \leq D$	*															
3	Others	Issues which is not defined defect :defect must be visible through 2% ND Filter.														



Class of defects	Definition	
	AQL 0.65	It is a defect that is likely to result in failure or to reduce materially the usability of the product for the intended function.
	AQL 1.5	It is a defect that will not result in functioning problem with deviation classified.

Note:1.(a)Bright point defect is defined as point defect of R,G,B with area >1/2 pixel respectively  
 (b)Dark point defect is defined as visible in full white pattern.  
 (c)The point defect must under 2% ND Filter visible .

Note:2 The external inspection should be conducted at the distance 30± 5cm between the eyes of inspector and the panel .

Note:3 Luminance measurement for contrast ratio is at the distance 50± 5cm between the detective head and the panel with ambient luminance less than 1 lux. Contrast ratio is obtained at optimum view angle.

Note:4 W-Width in mm , L-length of Max.(L1,L2) in mm.

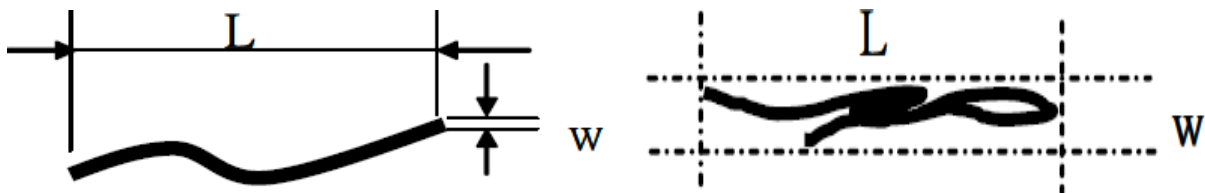

Note:5 Spot Foreign Material ( $W \geq L/4$ )

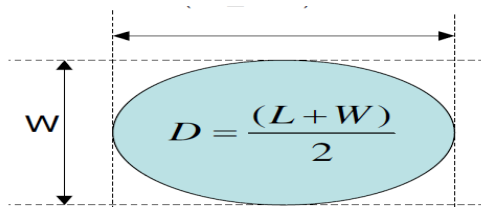

### 11.3 Sampling Condition

Unless otherwise agree in written, the sampling inspection shall be applied to the incoming inspection of customer.

Lot size: Quantity of shipment lot per model.

Sampling type: normal inspection, single sampling

Sampling table: ISO 2859

Inspection level: Level II

## 12. LCM PRODUCT LABEL DEFINE

Product Label style:

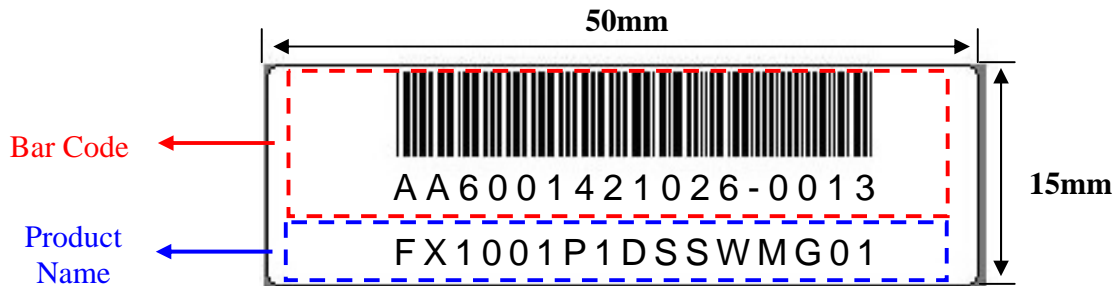

BarCode Define:

**A A 6 0014 2 10 26-0013**

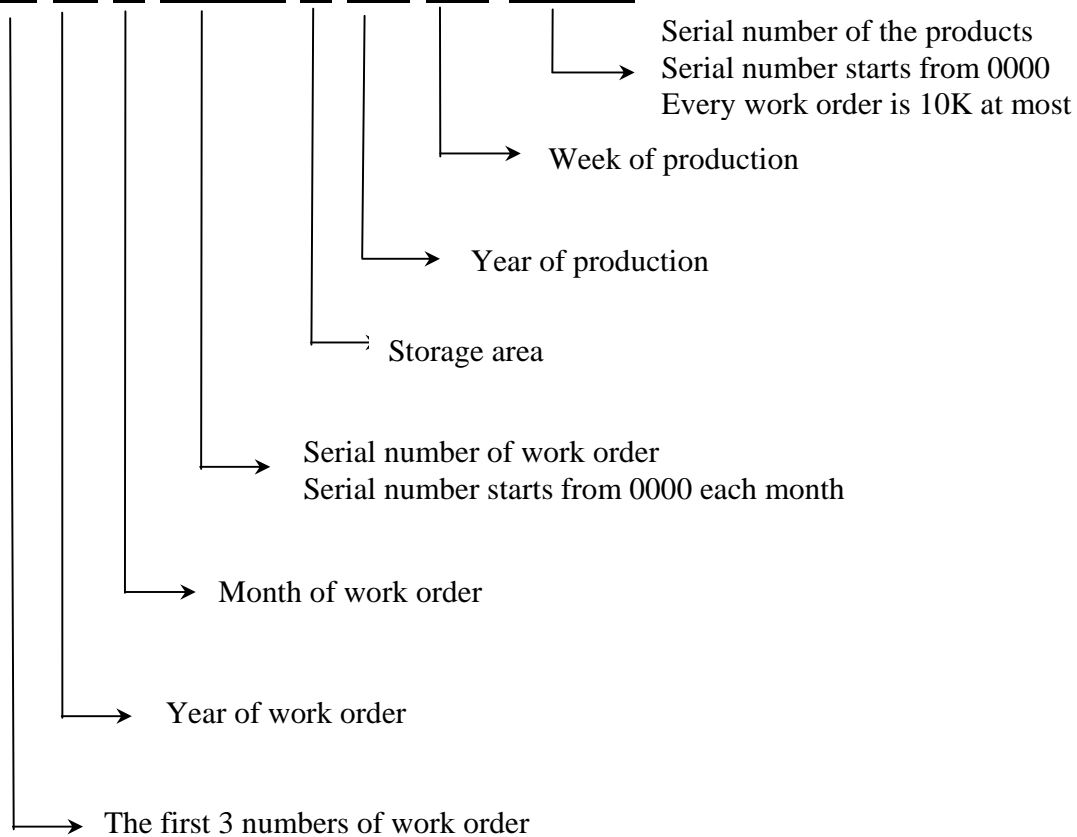

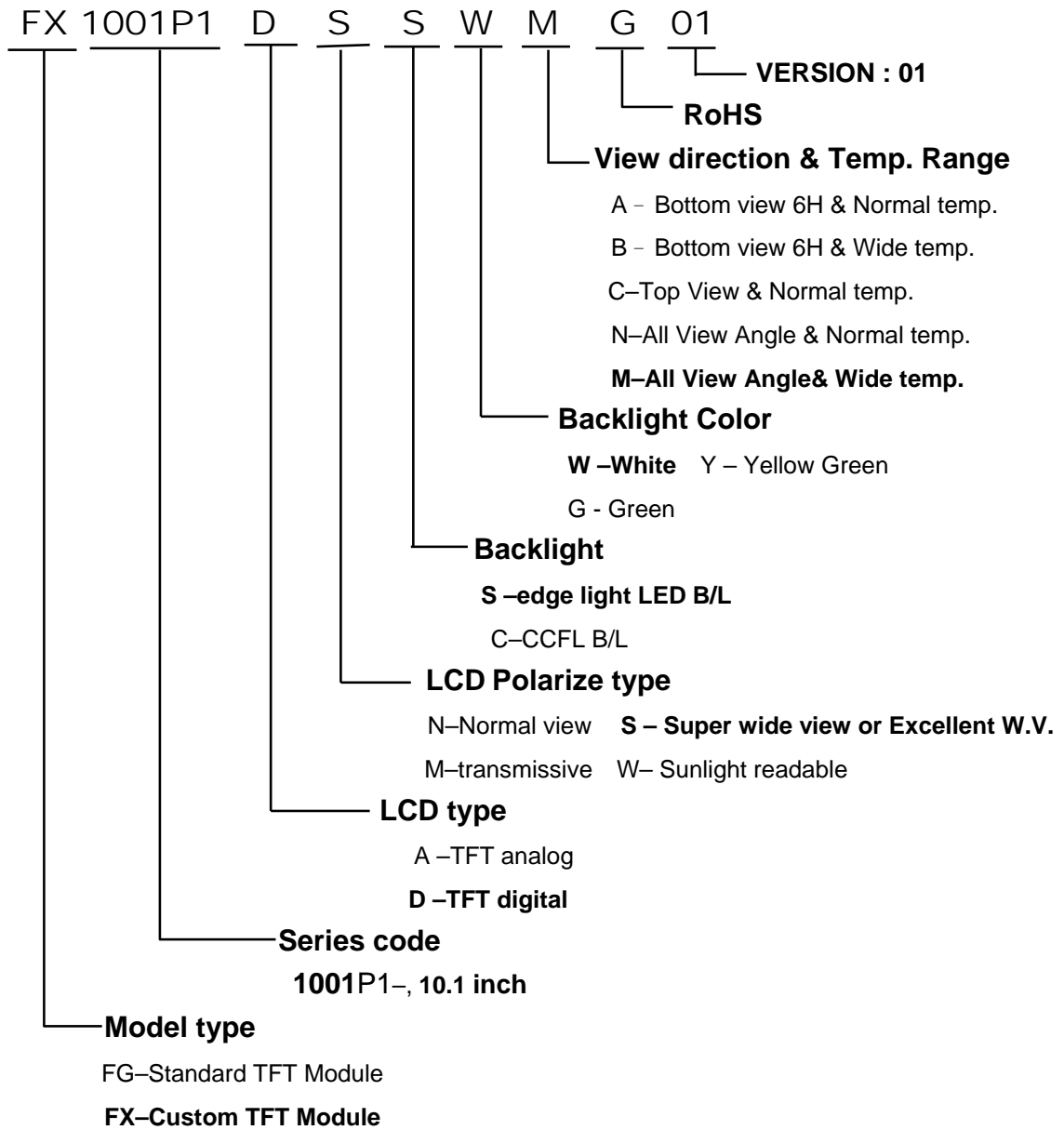
**Product Name Define:**

### 13. PRECAUTIONS IN USE LCM

#### 1. ASSEMBLY PRECAUTIONS

- (1) You must mount a module using holes arranged in four corners or four sides.
- (2) You should consider the mounting structure so that uneven force (ex. Twisted stress) is not applied to the module. And the case on which a module is mounted should have sufficient strength so that external force is not transmitted directly to the module.
- (3) Do not touch, push or rub the exposed polarizers with glass, tweezers or anything harder than HB pencil lead. And please do not rub with dust clothes with chemical treatment.
- (4) Wipe off saliva or water drops as soon as possible. Their long time contact with polarizer causes deformations and color fading.
- (5) Do not open the case because inside circuits do not have sufficient strength.
- (6) Please do not take a LCD module to pieces and reconstruct it. Resolving and reconstructing modules may cause them not to work well.
- (7) Please do not touch metal frames with bare hands and soiled gloves. A color change of the metal frames can happen during a long preservation of soiled LCD modules.
- (8) Please pay attention to handling lead wire of backlight so that it is not tugged in connecting with inverter.

#### 2. OPERATING PRECAUTIONS

- (1) Please be sure to turn off the power supply before connecting and disconnecting signal input cable.
- (2) Please do not change variable resistance settings in LCD module. They are adjusted to the most suitable value. If they are changed, it might happen LCD does not satisfy the characteristics specification
- (3) Be careful for condensation at sudden temperature change. Condensation makes damage to polarizer or electrical contacted parts. And after fading condensation, smear or spot will occur.
- (4) When fixed patterns are displayed for a long time, remnant image is likely to occur.
- (5) Module has high frequency circuits. Sufficient suppression to the electromagnetic interference shall be done by system manufacturers. Grounding and shielding methods may be important to minimize the interference.
- (6) Please consider that LCD backlight takes longer time to become stable of radiation characteristics in low temperature than in room temperature.

#### 3. ELECTROSTATIC DISCHARGE CONTROL

- (1) The operator should be grounded whenever he/she comes into contact with the module. Never touch any of the conductive parts such the copper leads on the PCB and the interface terminals with any

parts of the human body.

- (2) The modules should be kept in antistatic bags or other containers resistant to static for storage.
- (3) Only properly grounded soldering irons should be used.
- (4) If an electric screwdriver is used, it should be well grounded and shielded from commutator sparks.
- (5) The normal static prevention measures should be observed for work clothes and working benches; for the latter conductive (rubber) mat is recommended
- (6) Since dry air is inductive to statics, a relative humidity of 50-60% is recommended.

#### 4. STORAGE PRECAUTIONS

- (1) When you store LCDs for a long time, it is recommended to keep the temperature between 0°C-40°C without the exposure of sunlight and to keep the humidity less than 90%RH.
- (2) Please do not leave the LCDs in the environment of high humidity and high temperature such as 60°C 90%RH
- (3) Please do not leave the LCDs in the environment of low temperature; below -20°C.

#### 5. OTHERS

- (1) A strong incident light into LCD panel might cause display characteristics' changing inferior because of polarizer film, color filter, and other materials becoming inferior. Please do not expose LCD module direct sunlight and strong UV rays
- (2) Please pay attention to a panel side of LCD module not to contact with other materials in preserving it alone.
- (3) For the packaging box, please pay attention to the followings:
  - a. Please do not pile them up more than 5 boxes. (They are not designed so.) And please do not turn over.
  - b. Please handle packaging box with care not to give them sudden shock and vibrations. And also please do not throw them up.
  - c. Packing box and inner case for LCDs are made of cardboard. So please pay attention not to get them wet. (Such like keeping them in high humidity or wet place can occur getting them wet.)

#### 6. LIMITED WARRANTY

Unless otherwise agreed between DATA IMAGE and customer, DATA IMAGE will replace or repair any of its LCD and LCM which is found to be defective electrically and visually when inspected in accordance with DATA IMAGE acceptance standards, for a period on one year from date of shipment. Confirmation of such date shall be based on freight documents. The warranty liability of DATA IMAGE is limited to repair and/or replacement on the terms set forth above. DATA IMAGE will not responsible for any subsequent or consequential events.

Confidential Document  
**14. OUTLINE DRAWING**

**PRELIMINARY**

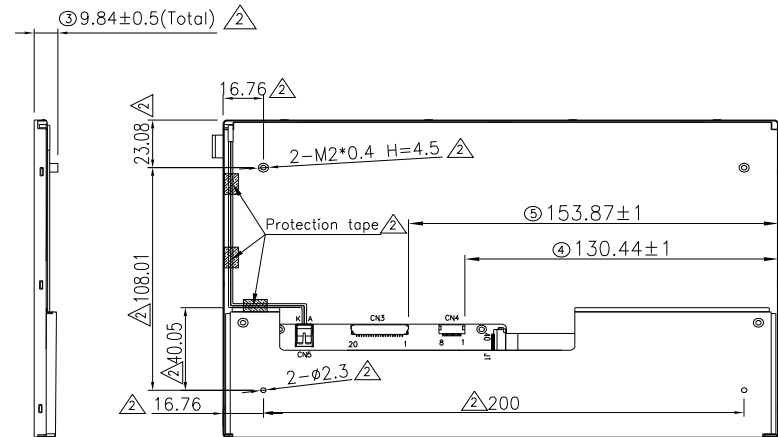
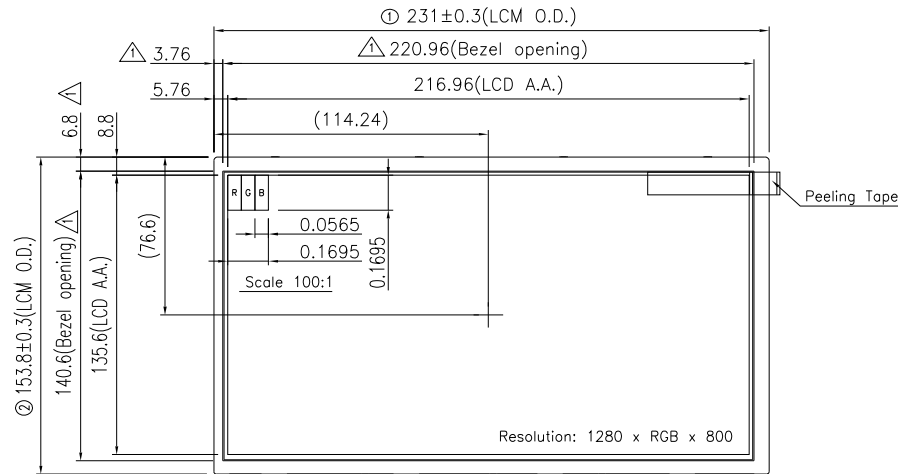

Note:

- For RoHS.
- Tolerance is ±0.3 unless otherwise noted.
- Important dimensions : ① ~ ⑤ .
- Center luminance : 500 cd/m<sup>2</sup> (Typ), 400 cd/m<sup>2</sup> (Min).
- CN3 connector : DF19G-20P-1H(54) (HIROSE).  
Matching connector : DF19G-20S-1C(05) (HIROSE).
- CN4 connector : SM08B-SHLS-G-TF(LF)(SN) (JST).  
Matching connector : SHLP-08V-S-B (JST).

CN3 FUNCTIONS			
1	NC	11	GND
2	BIST	12	RxIN1+
3	RxIN3+	13	RxIN1-
4	RxIN3-	14	GND
5	GND	15	RxIN0+
6	CK IN+	16	RxIN0-
7	CK IN-	17	GND
8	GND	18	NC
9	RxIN2+	19	VDD
10	RxIN2-	20	VDD

CN4 FUNCTIONS	
1	GND
2	BLBRT
3	BLBN
4	GND
5	VIN
6	VIN
7	VIN
8	GND

REVISIONS				DATE:	2015/11/3	TITLE: LCM OUTLINE DIMENSION	
△	Add four stand-offs& back cover on the back shield	ECR <110-FC0029>	2016/1/12	DRAWN:		DWG. NO.	FX1001P1SG01
△	Change the bezel opening dimensions	ECR <11S-FB0010>	2015/11/17	CHECK:		UNITS	M M
AUTH	DESCRIPTION	DATE	APPROVED	APPROVE:		SCALE	1 : 1
						REV.	3
						SHEET 1 OF 1	



**15. PACKAGE INFORMATION**  
**TBD**