

TFT-DISPLAY DATASHEET

DATA IMAGE

Model: FG0500E2DUSWVG01

BRIEF SPEC.:

Main Feature

Landscape

White LED Backlight

Active Screen Area	108.0 x 64.8 (mm)
Diagonal Format	5" 15:9
Resolution	800 X 480
Colors	262K/ 16.7M (6Bit)
Backlight	LED
Brightness	800 cd/m ²
LED Life Time	30K(h)
Interface	RGB
Viewing Angle	80/80 L/R 80/80
Touchscreen	No
Power Supply	3.3 V
Module Outline	118.4 x 77.45 x 4.18 (mm)
Operation Temperature	-30 ... +80 °C
Storage Temperature	-30... +80 °C
Surface Treatment	Anti-Glare



DATA IMAGE CORPORATION

TFT Module Specification Preliminary

ITEM NO.: FG0500E2DUSWMG01

Table of Contents

1. COVER & CONTENTS	1
2. RECORD OF REVISION	2
3. GENERAL SPECIFICATIONS	3
4. ABSOLUTE MAXIMUM RATINGS.....	3
5. ELECTRICAL CHARACTERISTICS	4
6. TIMING CHARACTERISTICS	5
7. PIN CONNECTIONS	7
8. POWER SEQUENCE.....	9
9. OPTICAL CHARACTERISTIC	10
10. QUALITY ASSURANCE	12
11. LCM PRODUCT LABEL DEFINE	16
12. PRECAUTIONS IN USE LCM	18
13. OUTLINE DRAWING	19
14. PACKAGE INFORMATION	20

Customer Companies	QA Approved	DQA Check	R&D Approved	R&D Check
	<i>Beth Jui</i>	<i>Huong</i>	<i>Alex</i>	<i>Yomo</i>
Customer Approved by	Version:	Issued Date:	Total Pages:	Prepared
	1	09/SEP/16'	20	<i>Rudy</i>

2. RECORD OF REVISION

Rev	Date	Item	Page	Comment	Source
1	09/SEP/16'			Initial Preliminary	ESR0509010

3. GENERAL SPECIFICATIONS

No.	Item	Specification	Unit
1	LCD size	5.0 (15: 9) Diagonal	inch
2	Outline Dimension	118.4x 77.45 x4.18	mm
3	Display Area	108.0 (H) x 64.8(V)	mm
4	Number of Pixel	800(H) x (RGB) x 480 (V)	pixels
5	Pixel pitch	0.135(H) x 0.135(V)	mm
6	Pixel arrangement	RGB Vertical stripe	
7	Display mode	Normally white	
8	Polarizer Surface treatment	Anti-Glare	
9	Weight	76	g
10	Back-light	LED Side-light type	
11	View direction	All	
12	LCD Clearing Point	> 95	°C

Remark: Our components and processes are compliant to RoHS standard.

4. ABSOLUTE MAXIMUM RATINGS

Parameter	Symbol	Min.	Max.	Unit	Remark
Power voltage	DV _{DD}	-0.3	5.0	V	
	AV _{DD}	-0.5	13.5	V	
	V _{GH}	-0.3	42.0	V	
	V _{GL}	-20.0	0.3	V	
	V _{GH} - V _{GL}	-	40.0	V	
Operating temperature	T _{OP}	-30	80	°C	
Storage temperature	T _{ST}	-30	80	°C	

Note : The absolute maximum rating values of this product are not allowed to be exceeded at any times. If a module be used with any of the absolute maximum ratings exceeded, the characteristics of the module may not be recovered..

5. ELECTRICAL CHARACTERISTICS

5.1 Typical operation conditions

Parameter	Symbol	Min.	Typ.	Max.	Unit	Remark
Power voltage	DV _{DD}	3.0	3.3	3.6	V	Note 2
	AV _{DD}	10.2	10.4	10.6	V	
	V _{GH}	15.8	16.0	16.2	V	
	V _{GL}	-6.2	-6.0	-5.8	V	
Input logic high voltage	V _{IH}	0.7 DV _{DD}	-	DV _{DD}	V	Note 3
Input logic low voltage	V _{IL}	0	-	0.3 DV _{DD}	V	

Note 1: Be sure to apply DV_{DD} and V_{GL} to the LCD first, and then apply V_{GH}.

Note 2: DV_{DD} setting should match the signals output voltage (refer to Note 3) of customer's system board.

Note 3: DCLK,HS,VS,RESET,U/D, L/R,DE,R0~R7,G0~G7,B0~B7,MODE,DITHB.

5.2 Current Consumption

Parameter	Symbol	Min.	Typ.	Max.	Unit	Remark
Current for Driver	I _{GH}	-	0.50	1	mA	V _{GH} =16.0V
	I _{GL}	-	0.54	1	mA	V _{GL} =-6.0V
	IDV _{DD}	-	4.2	10	mA	DV _{DD} =3.3V
	IAV _{DD}	-	19	50	mA	AV _{DD} =10.4V

5.3 Backlight Unit

The backlight system is an edge-lighting type with 18 LED

The characteristics of the LED are shown in the following tables.

Parameter	Symbol	Min.	Typ.	Max.	Unit	Remark
LED voltage	V _L	25	--	31.5	V	
LED current	I _L	--	40	--	mA	
LED Life Time		15,000	30,000	--	Hour	Note 1

Note 1: The "LED life time" is defined as the module brightness decrease to 50% original brightness at Ta=25°C and IL=40mA. The LED lifetime could be decreased if operating IL is larger than 40mA. The constant current driving method is suggested.



$$I_F = 20 \times 2 = 40 \text{ mA}, \quad V_F = 25 \sim 31.5 \text{ V}$$

backlight circuit

6. TIMING CHARACTERISTICS

6.1 AC Electrical Characteristics

Item	Symbol	Min.	Typ.	Max.	Unit	Remark
HS setup time	T_{hst}	8	-	-	ns	
HS hold time	T_{hhd}	8	-	-	ns	
VS setup time	T_{vst}	8	-	-	ns	
VS hold time	T_{vhd}	8	-	-	ns	
Data setup time	T_{dsu}	8	-	-	ns	
Data hole time	T_{dhd}	8	-	-	ns	
DE setup time	T_{esu}	8	-	-	ns	
DE hole time	T_{ehd}	8	-	-	ns	
DVDD Power On Slew rate	T_{POR}	-	-	20	ms	From 0 to 90% DVDD
RESET pulse width	T_{Rst}	1	-	-	ms	
DCLK cycle time	T_{coh}	20	-	-	ns	
DCLK pulse duty	T_{cwh}	40	50	60	%	

6.2 Input Clock and Data Timing Diagram

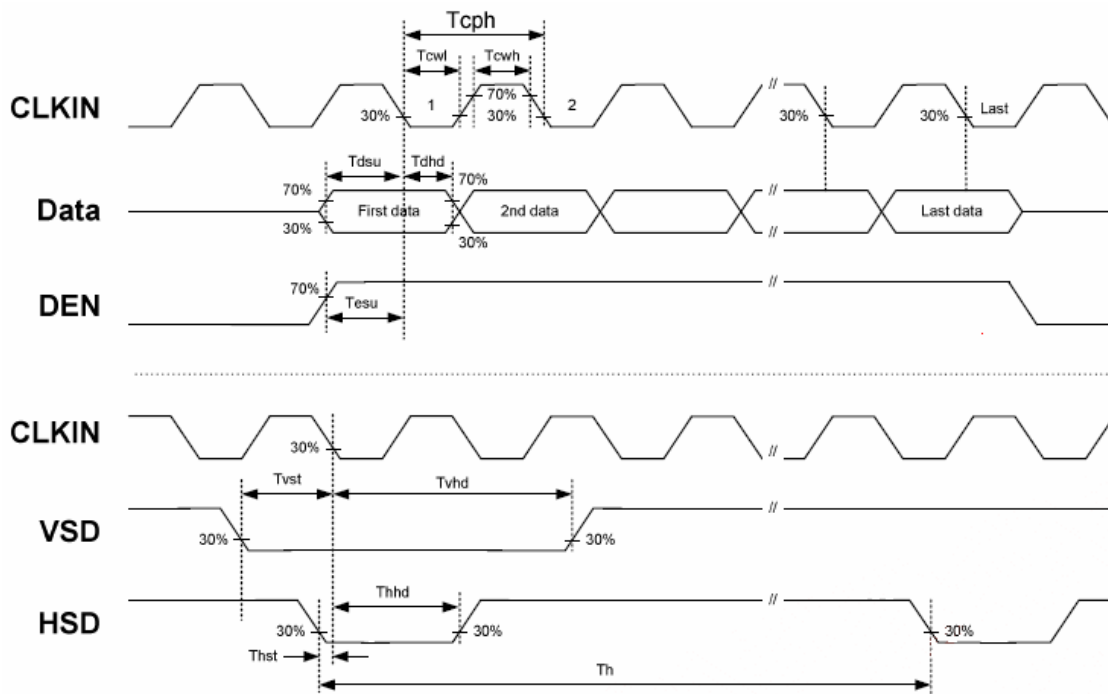

6.3 Timing

Item	Symbol	Min.	Typ.	Max.	Unit	Remark
Horizontal Display Area	thd	-	800	-	DCLK	
DCLK Frequency	fclk	26.4	33.3	46.8	MHz	
One Horizontal Line	th	862	1056	1200	DCLK	
HS pulse width	thpw	1	-	40	DCLK	
HS Blanking	thb	46	46	46	DCLK	
HS Front Porch	thfp	16	210	354	DCLK	

Item	Symbol	Min.	Typ.	Max.	Unit	Remark
Vertical Display Area	tvd	-	480	-	TH	
VS period time	tv	510	525	650	TH	
VS pulse width	tvpw	1	-	20	TH	
VS Blanking	tvb	23	23	23	TH	
VS Front Porch	tvfp	7	22	147	TH	

6.4 Data Input Format

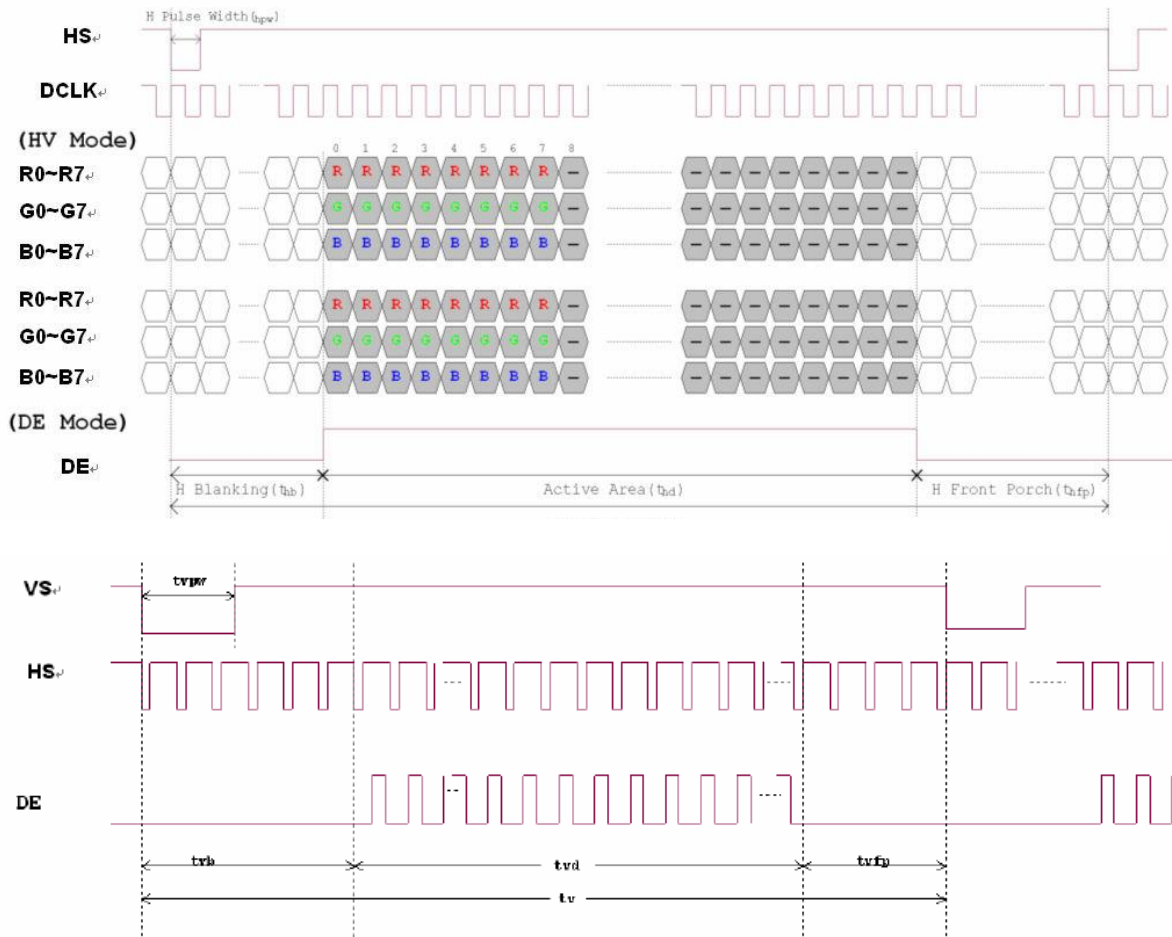

7. PIN CONNECTIONS

7.1 Input Pin Function

FPC Connector is used for the module electronics interface. The recommended model is FH12A-50S-0.5SH manufactured by Hirose.

Pin No.	Symbol	Description	Note
1	VLED1+	Power for LED backlight (Anode)	
2	VLED2+	Power for LED backlight (Anode)	
3	VLED1-	Power for LED backlight (Cathode)	
4	VLED2-	Power for LED backlight (Cathode)	
5	VGL	Gate OFF Voltage	
6	VGH	Gate ON Voltage	
7	GND	Power ground	
8	R0	Red data (LSB)	2
9	R1	Red data	2
10	R2	Red data	
11	R3	Red data	
12	R4	Red data	
13	GND	Power ground	
14	R5	Red data	
15	R6	Red data	
16	R7	Red data (MSB)	
17	G0	Green data (LSB)	2
18	G1	Green data	2
19	GND	Power ground	
20	G2	Green data	
21	G3	Green data	
22	G4	Green data	
23	G5	Green data	
24	G6	Green data	
25	GND	Power ground	
26	G7	Green data(MSB)	
27	B0	Blue data (LSB)	2
28	B1	Blue data	2
29	B2	Blue data	
30	B3	Blue data	
31	GND	Power ground	
32	B4	Blue data	
33	B5	Blue data	
34	B6	Blue data	
35	B7	Blue data(MSB)	
36	GND	Power ground	
37	DCLK	Sample clock	3
38	GND	Power ground	
39	DE	Data Input Enable	
40	HS	Horizontal Sync Input	
41	GND	Power ground	
42	VS	Vertical Sync Input	
43	RESET	Global reset pin.	6
44	U/D	Up/down selection	4,5
45	L/R	Left / right selection	4,5
46	MODE	DE/SYNC mode select	1
47	DITHB	Dithering function	7

48	DVDD	Power for Digital Circuit	
49	GND	Power Ground	
50	AVDD	Power for Analog Circuit	

I: input, O: output, P: Power

Note 1: DE/SYNC mode select. Normally pull high. When select DE mode, MODE="1", VS and HS must pull high. When select SYNC mode, MODE="0", DE must be grounded.

Note 2: When input 18 bits RGB data, the two low bits of R,G and B data must be grounded.

Note 3: Data shall be latched at the falling edge of DCLK.

Note 4: Selection of scanning mode

Setting of scan control input		Scanning direction
U/D	L/R	
DVDD	DVDD	Up to down, left to right
GND	GND	Down to up, right to left
DVDD	GND	Up to down, right to left
GND	DVDD	Down to up, left to right

Note 5: Definition of scanning direction.

Refer to the figure as below:

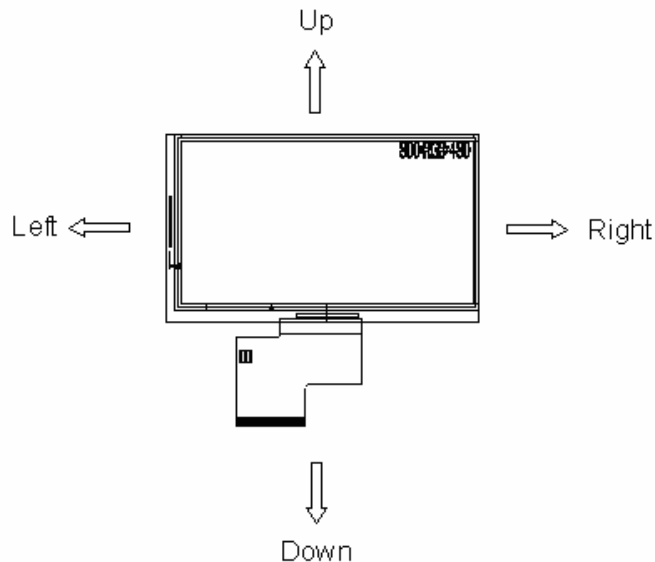

Note 6: Global reset pin. Active low to enter reset state. Suggest to connect with an RC reset circuit for stability. Normally pull high.

Note 7: Dithering function enable control, normally pull high.
 When DITHB="1", Disable internal dithering function,
 When DITHB="0", Enable internal dithering function,

8. POWER SEQUENCE

To prevent a latch-up or DC operation of the LCD module, the power on/off sequence should be as the diagram below.

Power on :

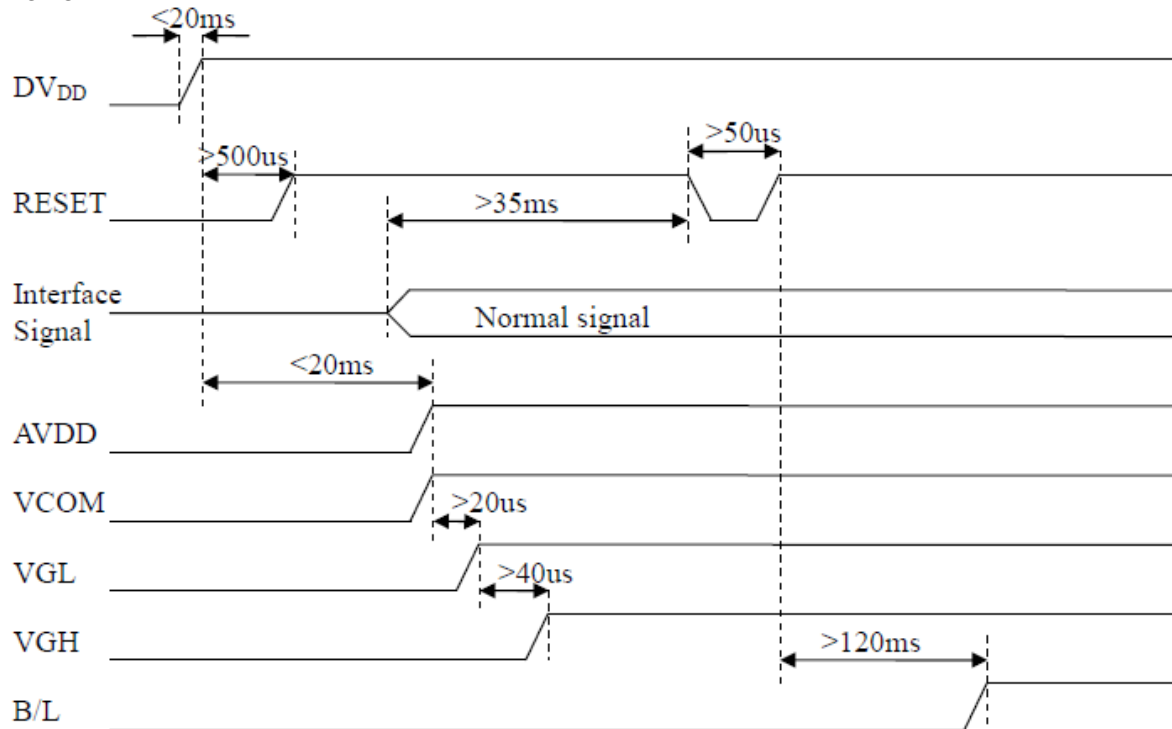

Power off :

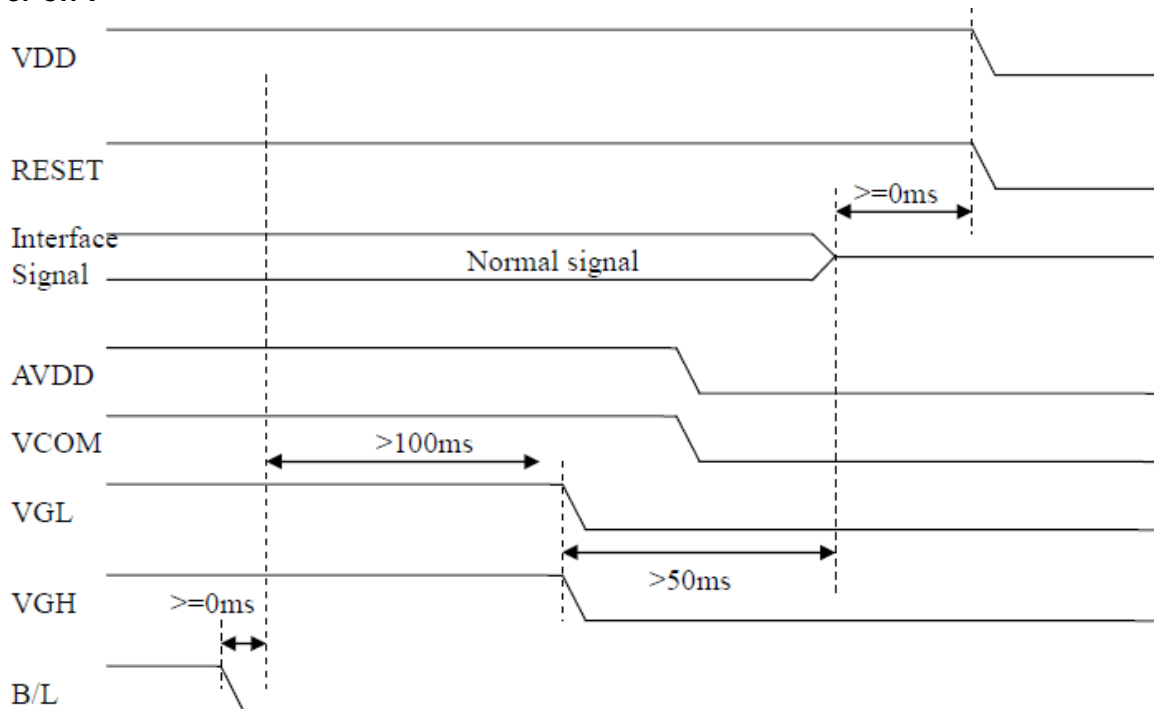

9. OPTICAL CHARACTERISTIC

Item		Symbol	Condition	Min.	Typ.	Max.	Unit	Remark
Response time	Rise	TON	Normal $\theta=\Phi=0^\circ$	-	10	20	ms	Note 3
	Fall	TOFF		-	15	30	ms	
Contrast ratio		CR		400	600			Note 4
Viewing angle	θ_L	$\Phi=180^\circ$ (9 o' clock)		70	80	-	Deg.	Note 1
	θ_R	$\Phi=0^\circ$ (3 o' clock)		70	80	-		
	θ_U	$\Phi=90^\circ$ (12 o' clock)		70	80	-		
	θ_D	$\Phi=270^\circ$ (6 o' clock)		70	80	-		
Brightness (Center)			Normal $\theta=\Phi=0^\circ$	640	800	--	cd/m ²	Note 5
Color chromaticity (CIE1931)	White	X		0.26	0.31	0.34		Note 5
		y		0.28	0.33	0.36		
Uniformity		B-uni	$\theta=\Phi=0^\circ$	70	-	-	%	Note 2,6

Test Conditions:

1. DVDD=3.3V, the ambient temperature is 25°C.
2. The test systems refer to Note 2.
3. LED Backlight current IL=40mA

Note 1: Definition of viewing angle range

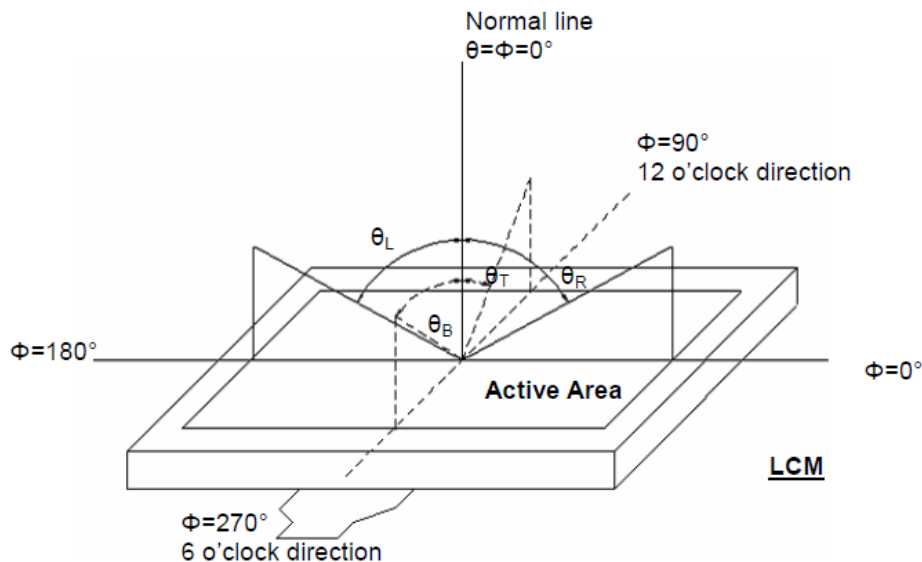

Note 2: Definition of optical measurement system.

The optical characteristics should be measured in dark room. After 5 minutes operation, the optical properties are measured at the center point of the LCD screen.
 (Viewing angle is measured by ELDIM-EZ contrast/Height :1.2mm, Response time is measured by Photo detector TOPCON BM-7, other items are measured by BM-5A/
 Field of view: 1° /Height: 500mm.)

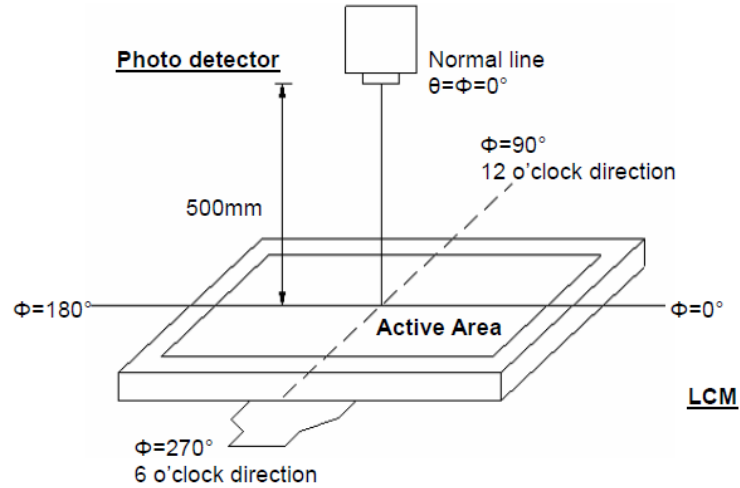

Note 3: Definition of Response time

The response time is defined as the LCD optical switching time interval between "White" state and "Black" state. Rise time (TON) is the time between photo detector output intensity changed from 90% to 10%. And fall time (TOFF) is the time between photo detector output intensity changed from 10% to 90%.

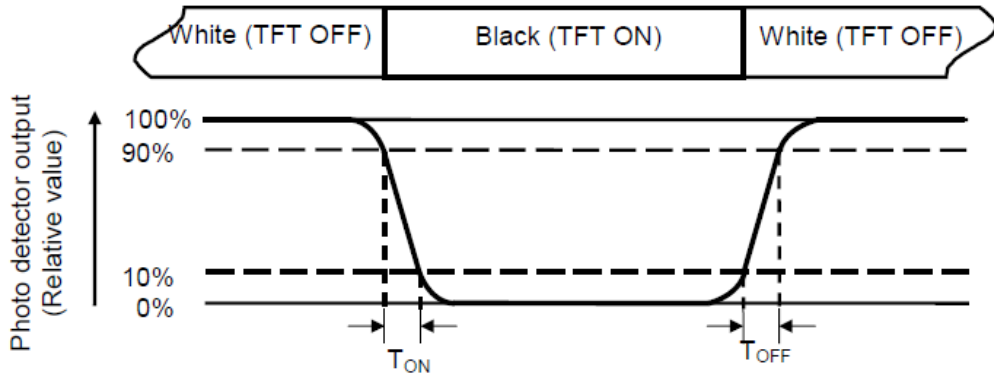

Note 4: Definition of contrast ratio

$$\text{Contrast ratio (CR)} = \frac{\text{Luminance measured when LCD on the "White" state}}{\text{Luminance measured when LCD on the "Black" state}}$$

Note 5: Measured at the center area of the panel when all terminals of LCD panel are electrically open. And backlight unit at typical backlight current.

Note 6: Definition of brightness uniformity (B-uni)

$$\text{B-uni} = \frac{\text{Minimum luminance of 9 points}}{\text{Maximum luminance of 9 points}} \quad (\text{Note 6}).$$

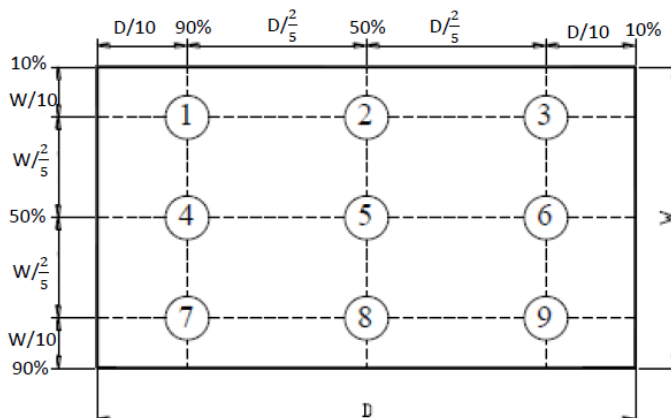

10. QUALITY ASSURANCE

10.1 Test Condition

10.1.1 Temperature and Humidity(Ambient Temperature)

Temperature : $25 \pm 5^{\circ}\text{C}$

Humidity : $65 \pm 5\%$

10.1.2 Operation

Unless specified otherwise, test will be conducted under function state.

10.1.3 Container

Unless specified otherwise, vibration test will be conducted to the product itself without putting it in a container.

10.1.4 Test Frequency

In case of related to deterioration such as shock test. It will be conducted only once.

10.1.5 Test Method

No.	Reliability Test Item & Level	Test Level	Remark
1	High Temperature Storage Test	T=80°C,240hrs	IEC68-2-2
2	Low Temperature Storage Test	T=-30°C,240hrs	IEC68-2-1
3	High Temperature Operation Test	T=80°C,240hrs	IEC68-2-2
4	Low Temperature Operation Test	T=-30°C,240hrs	IEC68-2-1
5	Thermal cycling storage test (no Operation)	-30°C ----25°C -----80°C ,100Cycle 30min 5min 30min	IEC68-2-14
6	Shock test	100G,6ms,Direction:±X±Y±Z Cycle:3times	IEC68-2-27
7	High temperature and high humidity operation test	T=60°C,90% RH,240hrs	IEC68-2-3
8	Drop test(with carton)	Height :60cm 1 conner,3edges,6surfaces	IEC68-2-32
9	vibration test(with carton)	Frequency:10~55HZ Amplitude:1.5mm Sweep time:11min Test period:6Cycles for each direction of X,Y,Z	IEC68-2-6
10	ESD test	State: operating Location: LCM/TP surface Condition:150pf 330Ω Contact +/- 6kV Air +/-8kV Criteria: Class C	IEC-61000-4-2

10.2 Inspection condition

10.2.1 Inspection conditions

10.2.1.1 Inspection Distance: 35 ± 5 cm

10.2.1.2 View Angle:

- (1) Inspection under operating condition : $\pm 5^\circ$
- (2) Inspection under non-operating condition : $\pm 45^\circ$

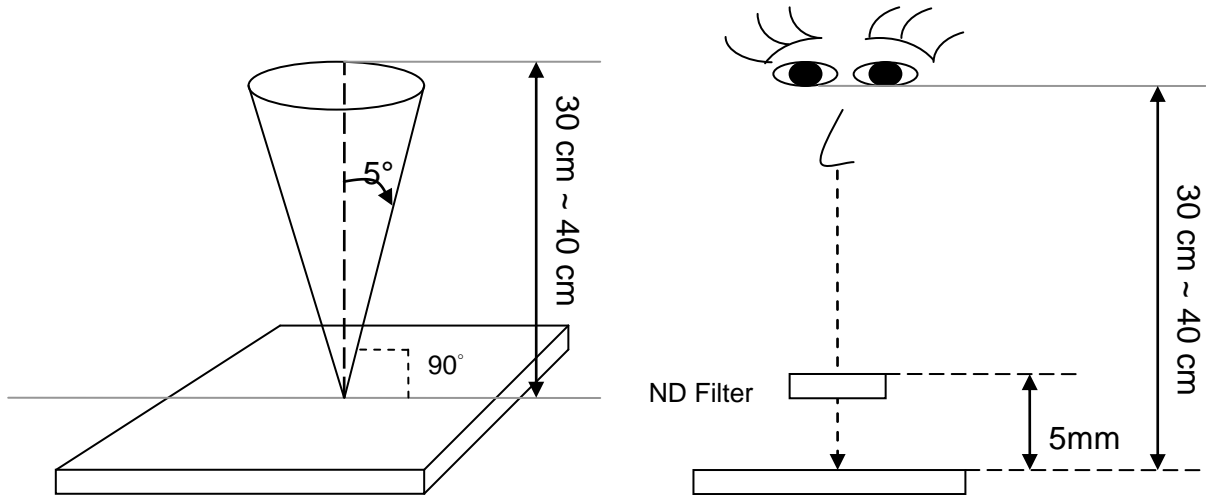

10.2.1.3 Environment conditions:

Ambient Temperature :		$25 \pm 5^\circ\text{C}$
Ambient Humidity :		$65 \pm 5\%$
Ambient Illumination	Cosmetic Inspection	500 ~ 800 lux
	Functional Inspection	300 ~ 500lux

10.2.2 Definition of applicable Zones



10.3 Inspection Parameters

No.	Parameter	Criteria																		
1	Operating	Display function: No Display malfunction (Major)																		
		Contrast ratio (Black, White): Does not meet specified range in the spec. (Major) (Note:3)																		
		Line Defect: No obvious Vertical and Horizontal line defect in bright, dark and colored. (Major) (Note:1)																		
		Point Defect (Red, green, blue, dark): Active area ≤ 2 dots (Major)(Note:1)																		
		<table border="1"> <thead> <tr> <th>Item</th> <th>Acceptable number</th> <th>Total</th> <th>Class Of Defects</th> <th>AQL Level</th> </tr> </thead> <tbody> <tr> <td>Bright</td> <td>0</td> <td rowspan="2">2</td> <td rowspan="4">Minor</td> <td rowspan="4">1.5</td> </tr> <tr> <td>Dark</td> <td>2</td> </tr> <tr> <td>Adjacent Bright</td> <td>0</td> <td>0</td> </tr> <tr> <td>Adjacent Dark</td> <td>0</td> <td>0</td> </tr> </tbody> </table>	Item	Acceptable number	Total	Class Of Defects	AQL Level	Bright	0	2	Minor	1.5	Dark	2	Adjacent Bright	0	0	Adjacent Dark	0	0
		Item	Acceptable number	Total	Class Of Defects	AQL Level														
		Bright	0	2	Minor	1.5														
		Dark	2																	
		Adjacent Bright	0	0																
		Adjacent Dark	0	0																
Foreign material in Black or White spots shape ($W > 1/4L$) (Note: 5)																				
<table border="1"> <thead> <tr> <th>Dimension</th> <th>Acceptable number</th> <th>Class Of Defects</th> <th>AQL Level</th> </tr> </thead> <tbody> <tr> <td>$D \leq 0.3$</td> <td>*</td> <td rowspan="3">Minor</td> <td rowspan="3">1.5</td> </tr> <tr> <td>$0.3 < D \leq 0.5$</td> <td>3</td> </tr> <tr> <td>$D > 0.5$</td> <td>0</td> </tr> </tbody> </table>	Dimension	Acceptable number	Class Of Defects	AQL Level	$D \leq 0.3$	*	Minor	1.5	$0.3 < D \leq 0.5$	3	$D > 0.5$	0								
Dimension	Acceptable number	Class Of Defects	AQL Level																	
$D \leq 0.3$	*	Minor	1.5																	
$0.3 < D \leq 0.5$	3																			
$D > 0.5$	0																			
$D = (\text{Long} + \text{Short}) / 2$ * : Disregard																				
Foreign Material in Line or spiral shape ($W \leq 1/4L$) (Note: 4)																				
<table border="1"> <thead> <tr> <th>Dimension</th> <th>Acceptable number</th> <th>Class Of Defects</th> <th>AQL Level</th> </tr> </thead> <tbody> <tr> <td>$W > 0.1\text{mm}, L > 5\text{mm}$</td> <td>0</td> <td rowspan="3">Major</td> <td rowspan="3">1.5</td> </tr> <tr> <td>$L \leq 5\text{mm}, 0.05\text{mm} < W \leq 0.1\text{mm}$</td> <td>3</td> </tr> <tr> <td>$L \leq 5\text{mm}, W < 0.05\text{mm}$</td> <td>*</td> </tr> </tbody> </table>	Dimension	Acceptable number	Class Of Defects	AQL Level	$W > 0.1\text{mm}, L > 5\text{mm}$	0	Major	1.5	$L \leq 5\text{mm}, 0.05\text{mm} < W \leq 0.1\text{mm}$	3	$L \leq 5\text{mm}, W < 0.05\text{mm}$	*								
Dimension	Acceptable number	Class Of Defects	AQL Level																	
$W > 0.1\text{mm}, L > 5\text{mm}$	0	Major	1.5																	
$L \leq 5\text{mm}, 0.05\text{mm} < W \leq 0.1\text{mm}$	3																			
$L \leq 5\text{mm}, W < 0.05\text{mm}$	*																			
L : Length W : Width * : Disregard																				
2	External Inspection (non-operating)	Dimension: Outline (Major)																		
		Bezel appearance: uneven (Major)																		
		Scratch on the polarize & Touch Panel: (Note:2) Scratch from the bezel edges to within 5mm: (Note:6)																		
		<table border="1"> <thead> <tr> <th>Dimension</th> <th>Acceptable number</th> <th>Class Of Defects</th> <th>AQL Level</th> </tr> </thead> <tbody> <tr> <td>$W > 0.1\text{mm}, L > 5\text{mm}$</td> <td>0</td> <td rowspan="3">Major</td> <td rowspan="3">1.5</td> </tr> <tr> <td>$L \leq 5\text{mm}, 0.05\text{mm} < W \leq 0.1\text{mm}$</td> <td>3</td> </tr> <tr> <td>$L \leq 5\text{mm}, W < 0.05\text{mm}$</td> <td>*</td> </tr> </tbody> </table>	Dimension	Acceptable number	Class Of Defects	AQL Level	$W > 0.1\text{mm}, L > 5\text{mm}$	0	Major	1.5	$L \leq 5\text{mm}, 0.05\text{mm} < W \leq 0.1\text{mm}$	3	$L \leq 5\text{mm}, W < 0.05\text{mm}$	*						
		Dimension	Acceptable number	Class Of Defects	AQL Level															
		$W > 0.1\text{mm}, L > 5\text{mm}$	0	Major	1.5															
		$L \leq 5\text{mm}, 0.05\text{mm} < W \leq 0.1\text{mm}$	3																	
		$L \leq 5\text{mm}, W < 0.05\text{mm}$	*																	
		L : Length W : Width * : Disregard																		
		Dent and spots shape on the polarize (Note:2): (Note: 5)																		
<table border="1"> <thead> <tr> <th>Dimension</th> <th>Acceptable number</th> <th>Class Of Defects</th> <th>AQL Level</th> </tr> </thead> <tbody> <tr> <td>$D \leq 0.3$</td> <td>*</td> <td rowspan="3">Major</td> <td rowspan="3">1.5</td> </tr> <tr> <td>$0.3 < D \leq 0.5$</td> <td>3</td> </tr> <tr> <td>$D > 0.5$</td> <td>0</td> </tr> </tbody> </table>	Dimension	Acceptable number	Class Of Defects	AQL Level	$D \leq 0.3$	*	Major	1.5	$0.3 < D \leq 0.5$	3	$D > 0.5$	0								
Dimension	Acceptable number	Class Of Defects	AQL Level																	
$D \leq 0.3$	*	Major	1.5																	
$0.3 < D \leq 0.5$	3																			
$D > 0.5$	0																			
$D = (\text{Long} + \text{Short}) / 2$ * : Disregard																				
Polarizer crack or delamination	Major																			
RTV seal, less than 0mm or more than 0.6mm	Major																			
RTV seal, discontinuous appearance	Major																			

Class of defects	Major	AQL 0.65	Definition
			Minor

Note:1 (a) Bright point defect is defined as point defect of Red or Green or Blue with area >1/2 dot respectively
 (b) Dark point defect is defined as visible in full white pattern.

Note:2 The external inspection should be conducted at the distance 35± 5cm between the eyes of inspector and the panel .

Note:3 Luminance measurement for contrast ratio is at the distance 50± 5cm between the detective head and the panel with ambient luminance less than 1 lux. Contrast ratio is obtained at the center of LCD perpendicular to the polarizer.

Note:4 W-Width in mm , L-length of Max.(L1,L2) in mm.

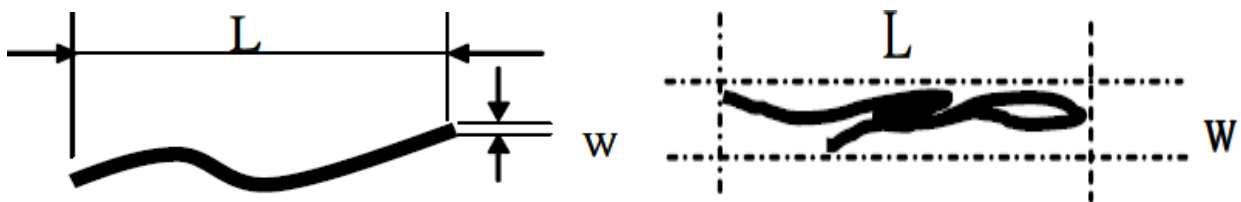

Note:5 Spot Foreign Material ($W \geq L/4$)

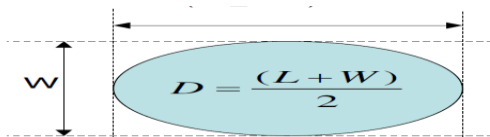

Note:6 Scratch from the bezel edges to within 5mm
 Drop IPA on the scratches and cover the transparent cover if by RGB and white five pictures check can't see the scratch, the LCM can shipment.

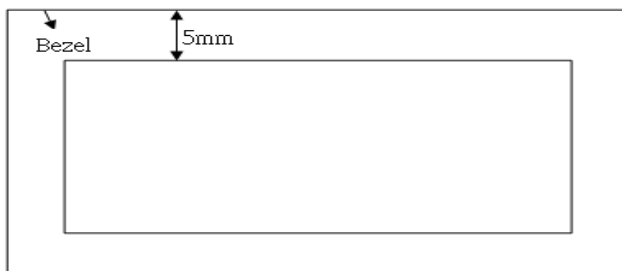

10.4 Sampling Condition

Unless otherwise agree in written, the sampling inspection shall be applied to the incoming inspection of customer.

Lot size: Quantity of shipment lot per model.

Sampling type: normal inspection, single sampling

Sampling table: ISO2859

Inspection level: Level II

11. LCM PRODUCT LABEL DEFINE

Product Label style:

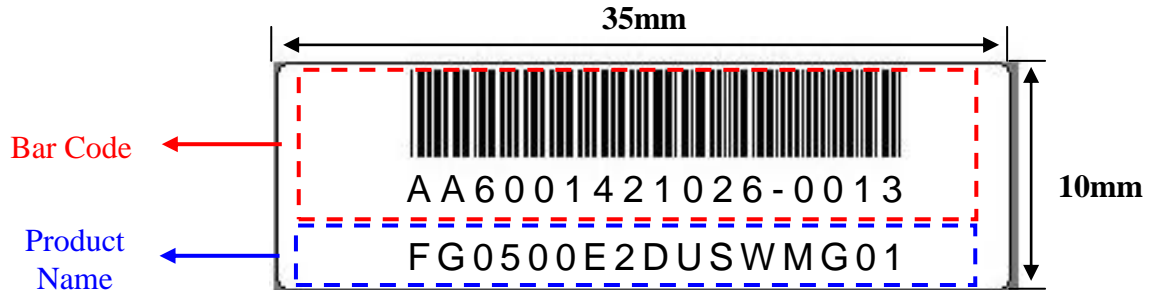

BarCode Define:

A A 6 0014 2 10 26-0013

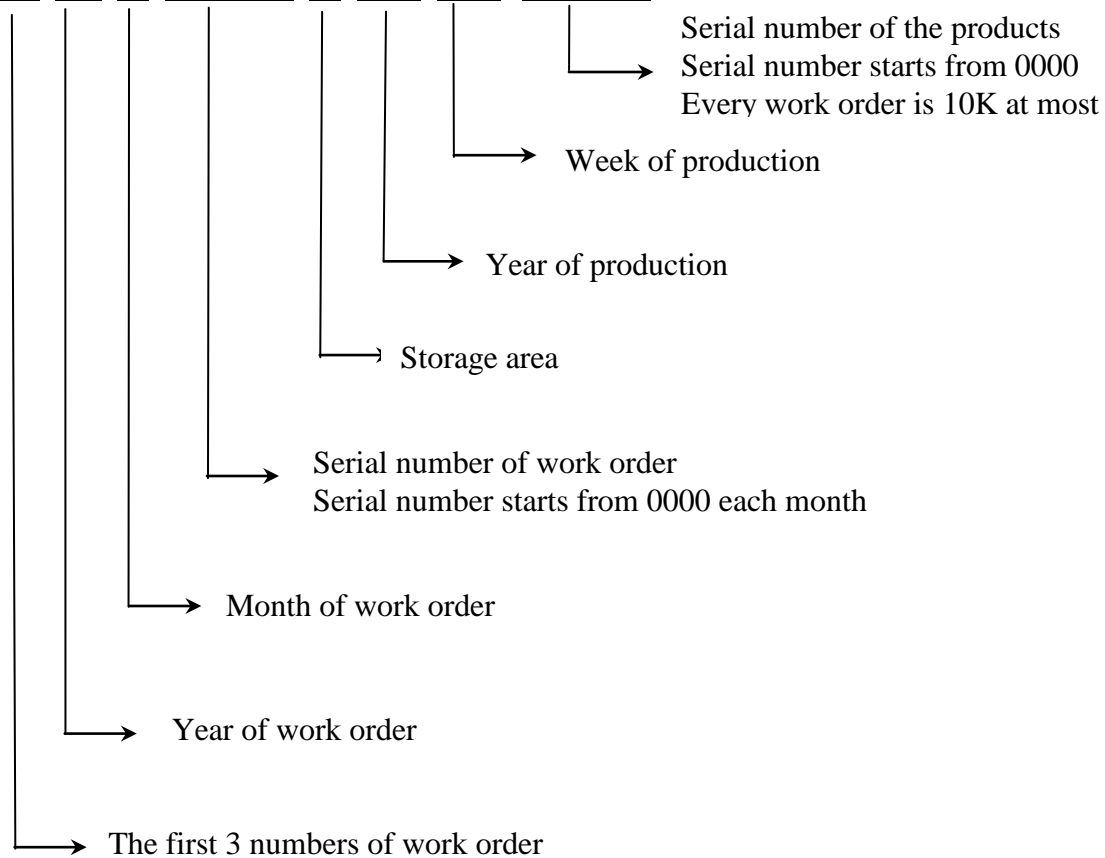

Product Name Define:

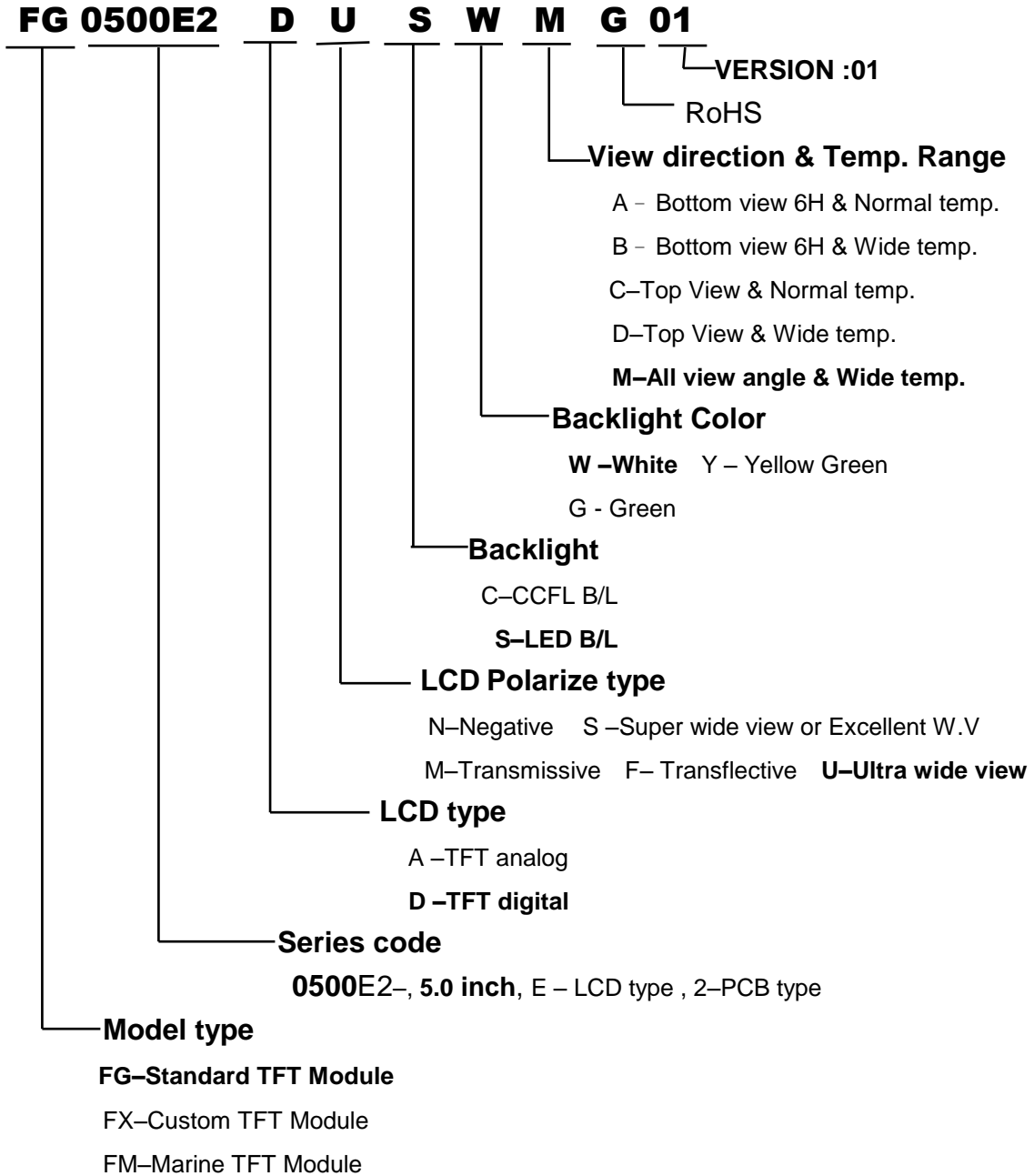

12. PRECAUTIONS IN USE LCM

1. ASSEMBLY PRECAUTIONS

- (1) You must mount a module using holes arranged in four corners or four sides.
- (2) You should consider the mounting structure so that uneven force (ex. Twisted stress) is not applied to the module. And the case on which a module is mounted should have sufficient strength so that external force is not transmitted directly to the module.
- (3) Do not touch, push or rub the exposed polarizers with glass, tweezers or anything harder than HB pencil lead. And please do not rub with dust clothes with chemical treatment.
- (4) Wipe off saliva or water drops as soon as possible. Their long time contact with polarizer causes deformations and color fading.
- (5) Do not open the case because inside circuits do not have sufficient strength.
- (6) Please do not take a LCD module to pieces and reconstruct it. Resolving and reconstructing modules may cause them not to work well.
- (7) Please do not touch metal frames with bare hands and soiled gloves. A color change of the metal frames can happen during a long preservation of soiled LCD modules.
- (8) Please pay attention to handling lead wire of backlight so that it is not tugged in connecting with inverter.

2. OPERATING PRECAUTIONS

- (1) Please be sure to turn off the power supply before connecting and disconnecting signal input cable.
- (2) Please do not change variable resistance settings in LCD module. They are adjusted to the most suitable value. If they are changed, it might happen LCD does not satisfy the characteristics specification
- (3) Be careful for condensation at sudden temperature change. Condensation makes damage to polarizer or electrical contacted parts. And after fading condensation, smear or spot will occur.
- (4) When fixed patterns are displayed for a long time, remnant image is likely to occur.
- (5) Module has high frequency circuits. Sufficient suppression to the electromagnetic interference shall be done by system manufacturers. Grounding and shielding methods may be important to minimize the interference.
- (6) Please consider that LCD backlight takes longer time to become stable of radiation characteristics in low temperature than in room temperature.

3. ELECTROSTATIC DISCHARGE CONTROL

The operator should be grounded whenever he/she comes into contact with the module. Never touch any of the conductive parts such the copper leads on the PCB and the interface terminals with any parts of the human body.

- (2) The modules should be kept in antistatic bags or other containers resistant to static for storage.
- (3) Only properly grounded soldering irons should be used.
- (4) If an electric screwdriver is used, it should be well grounded and shielded from commutator sparks.
- (5) The normal static prevention measures should be observed for work clothes and working benches; for the latter conductive (rubber) mat is recommended
- (6) Since dry air is inductive to statics, a relative humidity of 50-60% is recommended.

4. STORAGE PRECAUTIONS

- (1) When you store LCDs for a long time, it is recommended to keep the temperature between 0°C-40°C without the exposure of sunlight and to keep the humidity less than 90%RH.
- (2) Please do not leave the LCDs in the environment of high humidity and high temperature such as 60°C 90%RH
- (3) Please do not leave the LCDs in the environment of low temperature; below -20°C.

5. OTHERS

- (1) A strong incident light into LCD panel might cause display characteristics' changing inferior because of polarizer film, color filter, and other materials becoming inferior. Please do not expose LCD module direct sunlight and strong UV rays
- (2) Please pay attention to a panel side of LCD module not to contact with other materials in preserving it alone.
- (3) For the packaging box, please pay attention to the followings:
 - a. Please do not pile them up more than 5 boxes. (They are not designed so.) And please do not turn over.
 - b. Please handle packaging box with care not to give them sudden shock and vibrations. And also please do not throw them up.
 - c. Packing box and inner case for LCDs are made of cardboard. So please pay attention not to get them wet. (Such like keeping them in high humidity or wet place can occur getting them wet.)
- (4) Waste
Liquid crystal module products shall not be arbitrarily discarded; the water and soil have a negative impact on the environment, the need to be handled by a qualified unit.

6. LIMITED WARRANTY

Unless otherwise agreed between DATA IMAGE and customer, DATA IMAGE will replace or repair any of its LCD and LCM which is found to be defective electrically and visually when inspected in accordance with DATA IMAGE acceptance standards, for a period on one year from date of shipment. Confirmation of such date shall be based on freight documents. The warranty liability of DATA IMAGE is limited to repair and/or replacement on the terms set forth above. DATA IMAGE will not responsible for any subsequent or consequential events.

Confidential Document
13. OUTLINE DRAWING

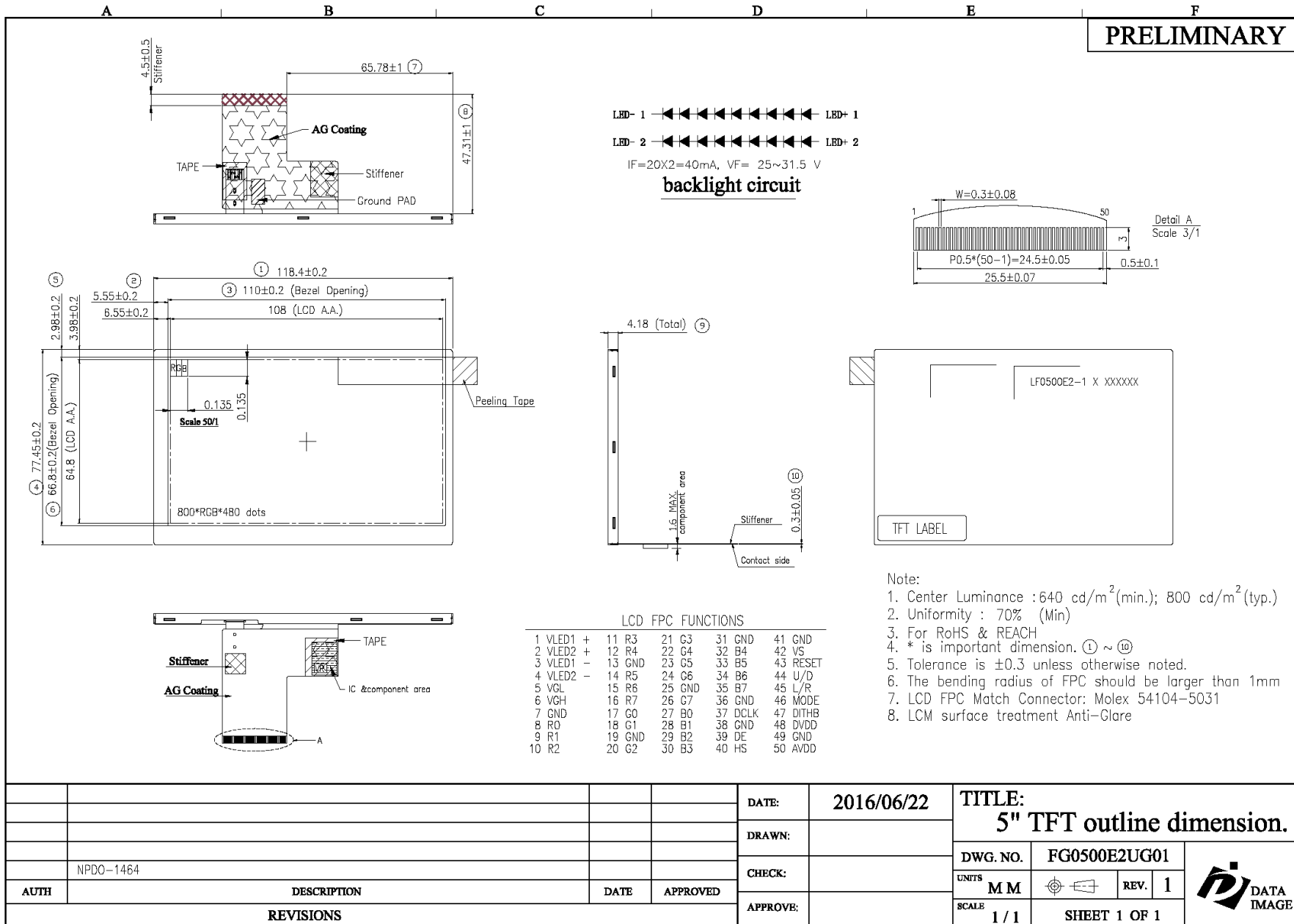

14. PACKAGE INFORMATION

T.B.D.