

TFT-DISPLAY DATASHEET

AUO
Model: P215HAN02.0

BRIEF SPEC.:

Main Feature

Wide Viewing Angle
White LED Backlight

Active Screen Area	476.06 x 267.78 (mm)
Diagonal Format	21.5" 16:9
Resolution	1920 X 1080
Colors	262K / 16.7M (6Bit)
Backlight	LED
Brightness	1500 cd/m ²
LED Life Time	50K(h)
Interface	LVDS
Viewing Angle	89/89 L/R 89/89
Touchscreen	No
Power Supply	5.0V
Module Outline	501.1 x 292.2 x 16.12 (mm)
Operation Temperature	0 ... +50 °C
Storage Temperature	-20... +60 °C
Surface Treatment	Anti Glare, Hardness 3H

Model Name: P215HAN02.0

Issue Date : 2017/12/11

- () Preliminary Specifications
- (*) Final Specifications

Customer Signature	Date	AUO	Date
Approved By _____		Approval By PM Director Jacky Su _____	
Note		Reviewed By RD Director Eugene CC Chen _____	
		Reviewed By Project Leader Amelia Huang _____	
		Prepared By PM YuHua YH Wu _____	

Contents

1. General Description	6
1.1. Display Characteristics	6
1.2. Optical Characteristics.....	7
1.3. Mechanical Characteristics.....	11
1.3.1. Placement Suggestions	11
1.3.2. Mechanical Characteristics	12
1.3.3. Absolute Maximum Ratings	13
2. Electrical Specification	14
2.1. Block Diagram	14
2.2. Interface Connection	15
2.2.1. Connector Type	15
2.2.2. Connector Pin Assignment	15
2.3. Electrical Characteristics	17
2.3.1. Absolute Maximum Rating	17
2.3.2. Recommended Operating Condition.....	17
2.4. Signal Characteristics.....	19
2.4.1. LCD Pixel Format	19
2.4.2. LVDS Data Format.....	19
2.4.3. Color versus Input Data	20
2.4.4. LVDS Specification	20
2.4.5. Input Timing Specification	23
2.4.6. Input Timing Diagram.....	24
2.5. Power ON/OFF Sequence.....	25
3. Backlight Unit	26
3.1. Block Diagram	26
3.2. Interface Connection	27
3.2.1. Connector Type	27
3.2.2. Connector Pin Assignment	28
3.3. Electrical Characteristics	29
3.3.1. Absolute Maximum Rating	29
3.3.2. Recommended Operating Condition.....	29
4. Reliability Test Items	31
5. International Standard	32
5.1. Safety	32
5.2. EMC	32
6. Packing	33
6.1. Definition of Label.....	33
6.2. Packing Methods.....	34

7. Precautions	36
7.1. Mounting Precautions.....	36
7.2. Operating Precautions.....	36
7.3. Operating Condition for Public Information Display	37
7.4. Electrostatic Discharge Control	37
7.5. Precautions for Strong Light Exposure	38
7.6. Storage	38
7.7. Handling Precautions for Protection Film	38

Record of Revision

Version	Date	Page	Description																																																																						
1.0	2017/07/25		First release																																																																						
1.1	2017/08/03	35	<p>Pallet and Shipment Information: box, packing box and pallet after packing dimension updated.</p> <table border="1" style="display: inline-table; margin-right: 20px;"> <thead> <tr> <th>Item</th> <th>Qty</th> <th>Specification</th> <th>Weight (kg)</th> <th>Remark</th> </tr> </thead> <tbody> <tr> <td>1</td> <td>1</td> <td>550 (mm) x 202 (mm) x 18.35 (mm)</td> <td>2.5</td> <td>None</td> </tr> <tr> <td>2</td> <td>1</td> <td>---</td> <td>3.75</td> <td>---</td> </tr> <tr> <td>3</td> <td>1</td> <td>550 (mm) x 202 (mm) x 270 (mm)</td> <td>7.8</td> <td>with Panel A</td> </tr> <tr> <td>4</td> <td>1</td> <td>550 (mm) x 202 (mm) x 370 (mm)</td> <td>13.75</td> <td>with Panel A</td> </tr> <tr> <td>5</td> <td>1</td> <td>1100 (mm) x 700 (mm) x 130 (mm)</td> <td>13.5</td> <td>None</td> </tr> <tr> <td>6</td> <td>1</td> <td>1100 (mm) x 700 (mm) x 227 (mm)</td> <td>23.2</td> <td>None</td> </tr> </tbody> </table> <table border="1" style="display: inline-table;"> <thead> <tr> <th>Item</th> <th>Qty</th> <th>Specification</th> <th>Weight (kg)</th> <th>Remark</th> </tr> </thead> <tbody> <tr> <td>1</td> <td>1</td> <td>550 (mm) x 202 (mm) x 18.35 (mm)</td> <td>2.5</td> <td>None</td> </tr> <tr> <td>2</td> <td>1</td> <td>---</td> <td>3.75</td> <td>---</td> </tr> <tr> <td>3</td> <td>1</td> <td>550 (mm) x 202 (mm) x 270 (mm)</td> <td>7.8</td> <td>with Panel A</td> </tr> <tr> <td>4</td> <td>1</td> <td>550 (mm) x 202 (mm) x 370 (mm)</td> <td>13.75</td> <td>with Panel A</td> </tr> <tr> <td>5</td> <td>1</td> <td>1100 (mm) x 700 (mm) x 130 (mm)</td> <td>13.5</td> <td>None</td> </tr> <tr> <td>6</td> <td>1</td> <td>1100 (mm) x 700 (mm) x 227 (mm)</td> <td>23.2</td> <td>None</td> </tr> </tbody> </table>	Item	Qty	Specification	Weight (kg)	Remark	1	1	550 (mm) x 202 (mm) x 18.35 (mm)	2.5	None	2	1	---	3.75	---	3	1	550 (mm) x 202 (mm) x 270 (mm)	7.8	with Panel A	4	1	550 (mm) x 202 (mm) x 370 (mm)	13.75	with Panel A	5	1	1100 (mm) x 700 (mm) x 130 (mm)	13.5	None	6	1	1100 (mm) x 700 (mm) x 227 (mm)	23.2	None	Item	Qty	Specification	Weight (kg)	Remark	1	1	550 (mm) x 202 (mm) x 18.35 (mm)	2.5	None	2	1	---	3.75	---	3	1	550 (mm) x 202 (mm) x 270 (mm)	7.8	with Panel A	4	1	550 (mm) x 202 (mm) x 370 (mm)	13.75	with Panel A	5	1	1100 (mm) x 700 (mm) x 130 (mm)	13.5	None	6	1	1100 (mm) x 700 (mm) x 227 (mm)	23.2	None
Item	Qty	Specification	Weight (kg)	Remark																																																																					
1	1	550 (mm) x 202 (mm) x 18.35 (mm)	2.5	None																																																																					
2	1	---	3.75	---																																																																					
3	1	550 (mm) x 202 (mm) x 270 (mm)	7.8	with Panel A																																																																					
4	1	550 (mm) x 202 (mm) x 370 (mm)	13.75	with Panel A																																																																					
5	1	1100 (mm) x 700 (mm) x 130 (mm)	13.5	None																																																																					
6	1	1100 (mm) x 700 (mm) x 227 (mm)	23.2	None																																																																					
Item	Qty	Specification	Weight (kg)	Remark																																																																					
1	1	550 (mm) x 202 (mm) x 18.35 (mm)	2.5	None																																																																					
2	1	---	3.75	---																																																																					
3	1	550 (mm) x 202 (mm) x 270 (mm)	7.8	with Panel A																																																																					
4	1	550 (mm) x 202 (mm) x 370 (mm)	13.75	with Panel A																																																																					
5	1	1100 (mm) x 700 (mm) x 130 (mm)	13.5	None																																																																					
6	1	1100 (mm) x 700 (mm) x 227 (mm)	23.2	None																																																																					
1.2	2017/08/25	5	Added note1 with pixel pitch in display characteristics table.																																																																						
1.2	2017/08/25	all	Updated note sequence.																																																																						
1.2	2017/08/25	28	Added LED string current: Max 51mA.																																																																						
1.2	2017/08/25	30	<p>Reliability test items: Updated item 5, 6(Vibration/drop test (With carton)) test condition and add item7, 8 (Vibration/Shock test (non-operation)).</p> <table border="1" style="display: inline-table; margin-right: 20px;"> <thead> <tr> <th>Test Item</th> <th>Qty</th> <th>Condition</th> </tr> </thead> <tbody> <tr> <td>1. High temperature storage test</td> <td>3</td> <td>50°C, 500hrs</td> </tr> <tr> <td>2. Low temperature storage test</td> <td>3</td> <td>20°C, 500hrs</td> </tr> <tr> <td>3. High temperature operation test</td> <td>3</td> <td>50°C, 500hrs</td> </tr> <tr> <td>4. Low temperature operation test</td> <td>3</td> <td>20°C, 500hrs</td> </tr> <tr> <td>5. Vibration test (With carton)</td> <td>1(PCB)</td> <td>Random wave(1.045ms 2-200Hz) Duration: X,Y,Z 20min per axis</td> </tr> <tr> <td>6. Drop test (With carton)</td> <td>1(PCB)</td> <td>Height: 25.4 cm Direction: Drop bottom flat twice. (ASTM D4168-1)</td> </tr> </tbody> </table> <table border="1" style="display: inline-table;"> <thead> <tr> <th>Test Item</th> <th>Qty</th> <th>Condition</th> </tr> </thead> <tbody> <tr> <td>7. High temperature storage test</td> <td>3</td> <td>50°C, 500hrs</td> </tr> <tr> <td>8. Low temperature storage test</td> <td>3</td> <td>20°C, 500hrs</td> </tr> <tr> <td>9. High temperature operation test</td> <td>3</td> <td>50°C, 500hrs</td> </tr> <tr> <td>10. Low temperature operation test</td> <td>3</td> <td>20°C, 500hrs</td> </tr> <tr> <td>11. Vibration test (With carton)</td> <td>1(PCB)</td> <td>Random wave(1.045ms 2-200Hz) Duration: X,Y,Z 20min per axis</td> </tr> <tr> <td>12. Drop test (With carton)</td> <td>1(PCB)</td> <td>Height: 25.4 cm Direction: Drop bottom flat twice. (ASTM D4168-1)</td> </tr> </tbody> </table>	Test Item	Qty	Condition	1. High temperature storage test	3	50°C, 500hrs	2. Low temperature storage test	3	20°C, 500hrs	3. High temperature operation test	3	50°C, 500hrs	4. Low temperature operation test	3	20°C, 500hrs	5. Vibration test (With carton)	1(PCB)	Random wave(1.045ms 2-200Hz) Duration: X,Y,Z 20min per axis	6. Drop test (With carton)	1(PCB)	Height: 25.4 cm Direction: Drop bottom flat twice. (ASTM D4168-1)	Test Item	Qty	Condition	7. High temperature storage test	3	50°C, 500hrs	8. Low temperature storage test	3	20°C, 500hrs	9. High temperature operation test	3	50°C, 500hrs	10. Low temperature operation test	3	20°C, 500hrs	11. Vibration test (With carton)	1(PCB)	Random wave(1.045ms 2-200Hz) Duration: X,Y,Z 20min per axis	12. Drop test (With carton)	1(PCB)	Height: 25.4 cm Direction: Drop bottom flat twice. (ASTM D4168-1)																												
Test Item	Qty	Condition																																																																							
1. High temperature storage test	3	50°C, 500hrs																																																																							
2. Low temperature storage test	3	20°C, 500hrs																																																																							
3. High temperature operation test	3	50°C, 500hrs																																																																							
4. Low temperature operation test	3	20°C, 500hrs																																																																							
5. Vibration test (With carton)	1(PCB)	Random wave(1.045ms 2-200Hz) Duration: X,Y,Z 20min per axis																																																																							
6. Drop test (With carton)	1(PCB)	Height: 25.4 cm Direction: Drop bottom flat twice. (ASTM D4168-1)																																																																							
Test Item	Qty	Condition																																																																							
7. High temperature storage test	3	50°C, 500hrs																																																																							
8. Low temperature storage test	3	20°C, 500hrs																																																																							
9. High temperature operation test	3	50°C, 500hrs																																																																							
10. Low temperature operation test	3	20°C, 500hrs																																																																							
11. Vibration test (With carton)	1(PCB)	Random wave(1.045ms 2-200Hz) Duration: X,Y,Z 20min per axis																																																																							
12. Drop test (With carton)	1(PCB)	Height: 25.4 cm Direction: Drop bottom flat twice. (ASTM D4168-1)																																																																							
1.2	2017/08/25	36	Deleted 7.3 (2) a(* The moving picture can be allowed for 24 hours a day)																																																																						
1.3	2017/09/04	5	<p>Modified prim pitch unit.</p> <p>A. Prism film pitch: 50mm. → Prism film pitch: 50um.</p>																																																																						
1.4	2017/12/11	6	Added "High Tni (110°C) liquid crystal is also applied on this model to enhance the sunlight readability" in General Description.																																																																						
1.4	2017/12/11	12	<p>Modified the label position.</p>																																																																						
1.4	2017/12/11	31	<p>Modified reliability test items.</p> <p>A. Item5 Vibration test (With carton): Q'ty_1CNT/8PCS → 1CNT/7PCS.</p> <p>B. Item6 Drop test (With carton): Q'ty_1CNT/8PCS → 1CNT/7PCS. Condition_ Height 45.7cm → 61cm.</p>																																																																						

1.4	2017/12/11	34	<p>Changed the packing method.</p> <p>A. Packing material: Anti-static bag → Aluminum foil bag</p> <p>B. Packing Q'ty/box: 8pcs/box → 7pcs/box.</p>
1.4	2017/12/11	35	<p>Modified pallet and shipment Information.</p> <p>A. Packing box: Q'ty_8pcs/box → 7pcs/box / Weight_18.75kg →16.57kg</p> <p>B. Pallet after packing: Weight_351.3kg →321.1kg.</p>

1. General Description

This specification applies to the 21.5 inch wide Color a-Si TFT-LCD Module P215HAN02.0. The display supports the Full HD - 1920(H) x 1080(V) screen format and 16.7M colors (8 bits RGB data input). The input interface is Dual channel LVDS and this module doesn't contain a driver board for backlights. High Tni (110°C) liquid crystal is also applied on this model to enhance the sunlight readability.

* General Information

1.1. Display Characteristics

The following items are characteristics summary on the table under 25□ condition:

ITEMS	Unit	SPECIFICATIONS	Note
Screen Diagonal	[mm]	546.86 (21.5")	
Active Area	[mm]	476.064 (H) x 267.786 (V)	
Pixels H x V	-	1920(x3) x 1080	
Pixel Pitch	[um]	247.95 (per one triad) ×247.95	Note1
Pixel Arrangement	-	R.G.B. Vertical Stripe	
Display Mode	-	AHVA, normally Black	
White Luminance (Center)	[cd/m2]	1500 (Typ.)	
Contrast Ratio	-	1000 (Typ.)	
Response Time	[msec]	25 (Typ., G/G)	
Power Consumption (LCD Module+Backlight unit)	[Watt]	38.1 (Typ.) LCD module : PDD (Typ.)= 2.3@White pattern,Fv=60Hz Backlight unit : P _{BLU} (Typ.) =35.8@Is= 47 mA	
Weight	[Grams]	2.1 Kg	
Outline Dimension	[mm]	501.1(H) × 292.2(V) ×16.12 (D) Typ	
Electrical Interface	-	Dual channel LVDS , 8-bit RGB data input	
Support Color	-	16.7M colors	
Surface Treatment	-	Anti-Glare, 3H	Haze=25%
Rotate Function		Unachievable	Note 2
Display Orientation		Portrait/Landscape Enabled	Note 3

Note1: If this model will be used for touch application, please refer to the following parameters in order to avoid the light interference. (ex. Moire)

- A. Pixel pitch: 247.95um.
- B. Prism film pitch: 50um.
- C. Prism film angle: 0 and 90 degree.

Note 2: Rotate Function refers to LCD display could be able to rotate. This function does not work in this model.

Note 3: Please refer to 1.3.1 Placement Suggestions.

1.2. Optical Characteristics

The optical characteristics are measured on the following test condition.

Test Condition:

1. Equipment setup: Please refer to Note 1-1.
2. Panel Lighting time: 30 minutes
3. VDD=5.0V, Fv=60Hz, Is=55mA, Ta=25°C

Symbol	Description		Min.	Typ.	Max.	Unit	Remark
Lw	White Luminance (Center of screen)		1200	1500	-	[cd/m ²]	Note 1-1 By SR-3
Luni	Luminance Uniformity (9 points)		75	80	-	[%]	Note 1-2 By SR-3
CR	Contrast Ratio (Center of screen)		600	1000	-	-	Note 1-3 By SR-3
θR	Horizontal Viewing Angle (CR=10)	Right	75	89	-	[degree]	Note 1-4 By SR-3
θL		Left	75	89	-		
ΦH	Vertical Viewing Angle (CR=10)	Up	75	89	-		
ΦL		Down	75	89	-		
θR	Horizontal Viewing Angle (CR=5)	Right	75	89	-		
θL		Left	75	89	-		
ΦH	Vertical Viewing Angle (CR=5)	Up	75	89	-		
ΦL		Down	75	89	-		
T _{GTG}	Response Time	Gray to Gray	-	25	-	[msec]	Note 1-5 By TRD-100
Rx	Color Coordinates (CIE 1931)	Red x	0.615	0.645	0.675	-	By SR-3
Ry		Red y	0.308	0.338	0.368		
Gx		Green x	0.290	0.320	0.350		
Gy		Green y	0.590	0.620	0.650		
Bx		Blue x	0.120	0.150	0.180		
By		Blue y	0.025	0.055	0.085		
Wx		White x	0.283	0.313	0.343		
Wy		White y	0.299	0.329	0.359		
NTSC Area Ratio				72		[%]	By SR-3
CT	Crosstalk		-	-	1.5	[%]	Note 1-6 By SR-3

Note 1-1: Equipment setup :

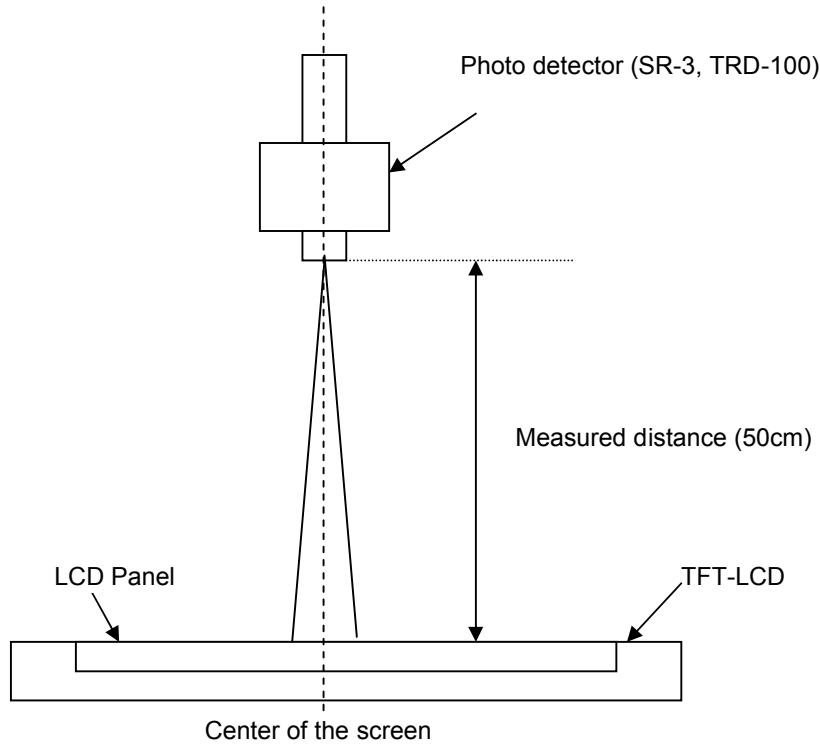

Note 1-2: Luminance Uniformity Measurement

Definition:

$$\text{Luminance Uniformity} = \frac{\text{Minimum Luminance of 9 Points (P1 ~ P9)}}{\text{Maximum Luminance of 9 Points (P1 ~ P9)}}$$

a. Test pattern: White Pattern

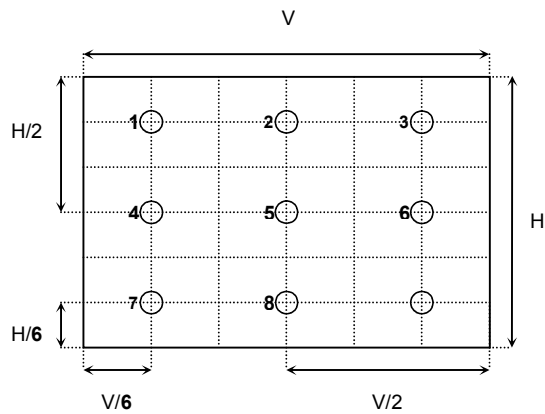

Note 1-3: Contrast Ratio Measurement

Definition:

$$\text{Contrast Ratio} = \frac{\text{Luminance of White pattern}}{\text{Luminance of Black pattern}}$$

- a. Measured position: Center of screen (P5) & perpendicular to the screen ($\theta = \Phi = 0^\circ$)

Note 1-4: Viewing angle measurement

Definition: The angle at which the contrast ratio is greater than 10 & 5 .

- a. Horizontal view angle: Divide to left & right (θ_L & θ_R)

Vertical view angle: Divide to up & down (Φ_H & Φ_L)

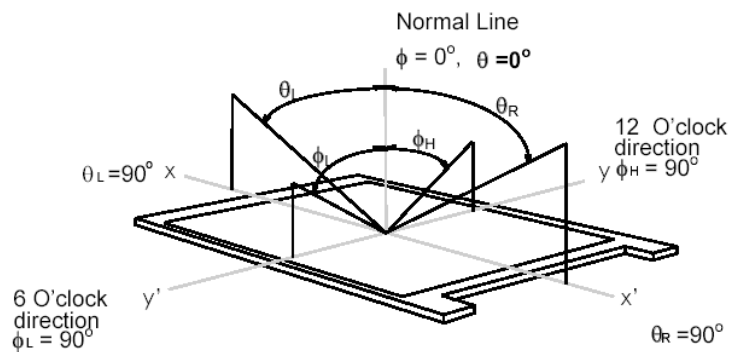

Note 1-5: Response time measurement

The output signals of photo detector are measured when the input signals are changed from “Gray level A” to “Gray level B” (falling time, T_f), and from “Gray level B” to “Gray level A” (rising time, T_r), respectively. The response time is interval between the 10% and 90% of optical response.

The gray to gray response time is defined as the following table.

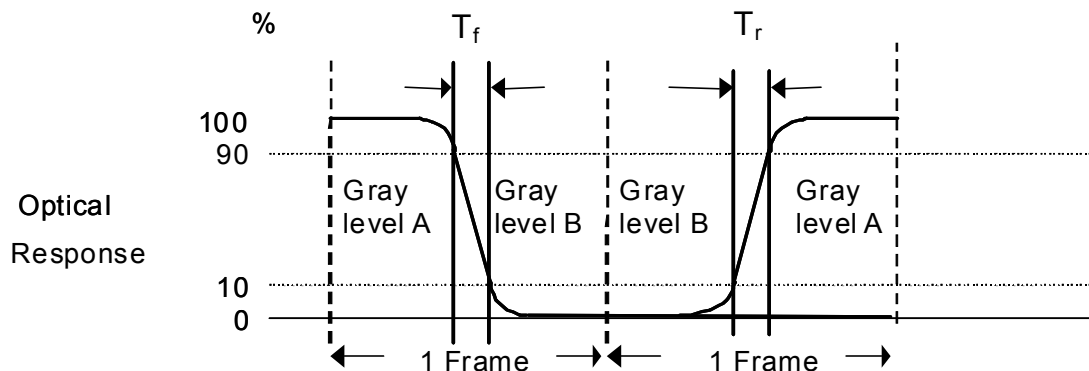

Gray Level to Gray Level		Target gray level				
		L0	L63	L127	L191	L255
Start gray level	L0					
	L63					
	L127					
	L191					
	L255					

■ T_{GTG_typ} is the total average time at rising time and falling time of gray to gray.

Note 1-6: Crosstalk measurement

Definition:

$CT = \text{Max. } (CTH, CTV);$

Where

a. Maximum Horizontal Crosstalk :

$CTH = \text{Max. } (|Y_{BL} - Y_{AL}| / Y_{AL} \times 100 \%, |Y_{BR} - Y_{AR}| / Y_{AR} \times 100 \%);$

Maximum Vertical Crosstalk:

$CTV = \text{Max. } (|Y_{BU} - Y_{AU}| / Y_{AU} \times 100 \%, |Y_{BD} - Y_{AD}| / Y_{AD} \times 100 \%);$

b. $Y_{AU}, Y_{AD}, Y_{AL}, Y_{AR}$ = Luminance of measured location without Black pattern

$Y_{BU}, Y_{BD}, Y_{BL}, Y_{BR}$ = Luminance of measured location with Black pattern

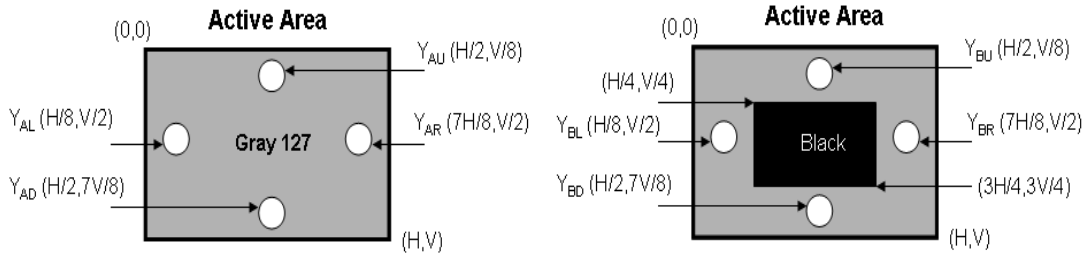

1.3. Mechanical Characteristics

The contents provide general mechanical characteristics for the model P215HAN02.0. In addition the figures in the next page are detailed mechanical drawing of the LCD.

Item		Dimension	Unit	Note
Outline Dimension	Horizontal	501.1	mm	
	Vertical	292.2	mm	
	Depth (typ)	16.12	mm	
Weight	2100		G	

1.3.1. Placement Suggestions

1. Landscape Mode: The default placement is T-Con Side on the lower side and the image is shown upright via viewing from the front.
2. Portrait Mode: The default placement is that T-Con side has to be placed on the left side via viewing from the front.

Landscape (Front view)

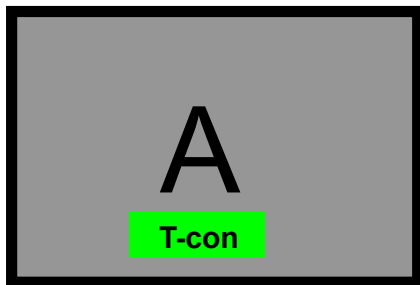

Portrait (Front view)

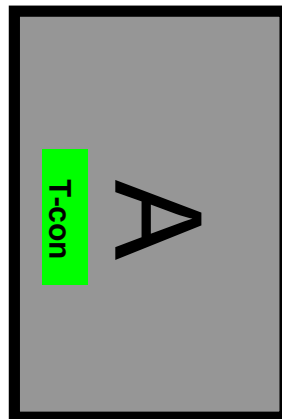

1.3.2. Mechanical Characteristics

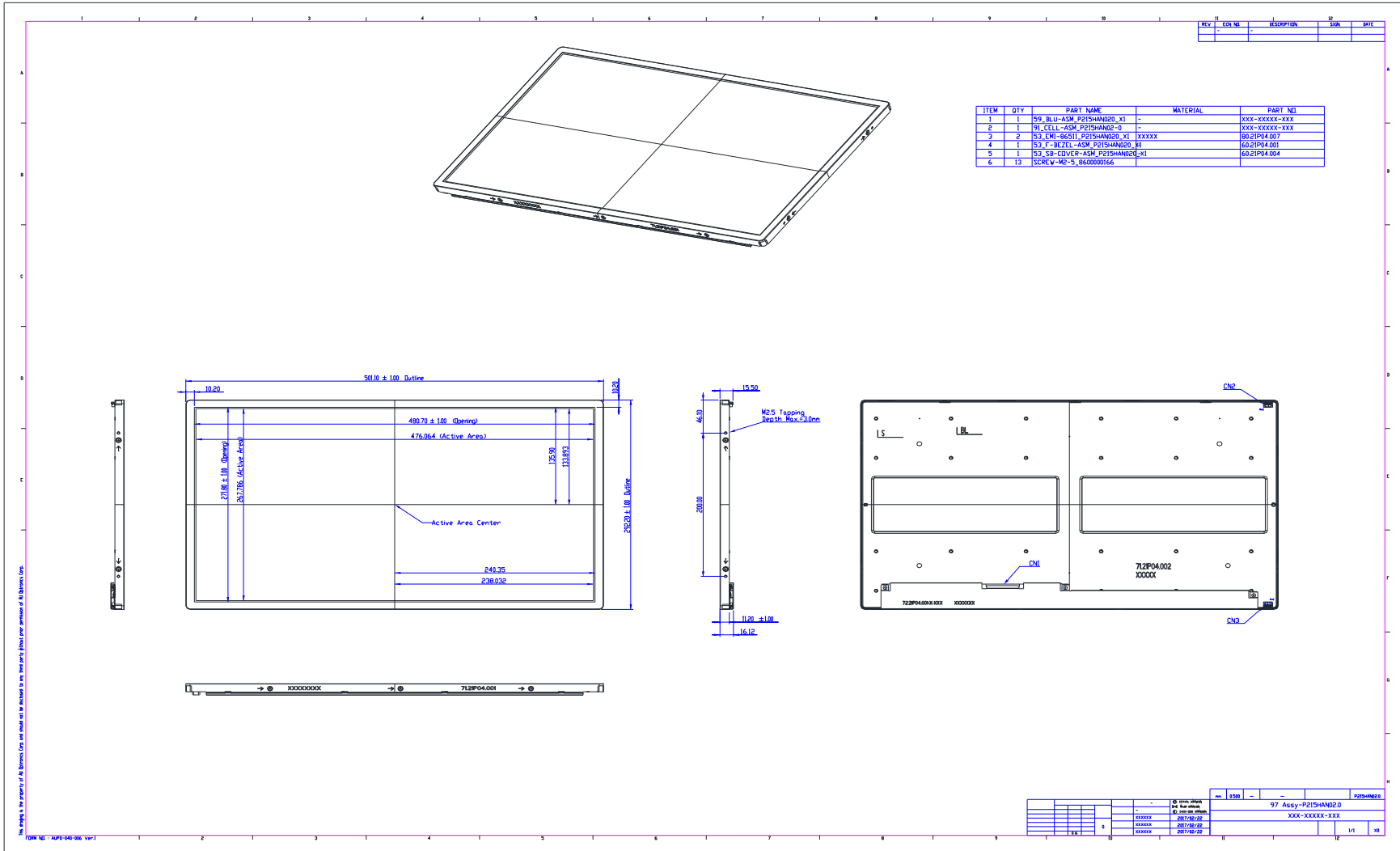

1.3.3. Absolute Maximum Ratings

The followings are maximum values which, if exceeded, may cause faulty operation or damage to the unit
Permanent damage may occur if exceeding the following maximum rating.

Item	Symbol	Min	Max	Unit	Conditions
Operating Temperature	TOP	0	+50	[°C]	Note 1-7
Operating Humidity	HOP	10	90	[%RH]	Note 1-7
Storage Temperature	TST	-20	+60	[°C]	Note 1-7
Storage Humidity	HST	10	90	[%RH]	Note 1-7
Panel Surface Temperature	PST		65	[°C]	Note 1-8

Note 1-7: Maximum Wet-Bulb should be 39□ and No condensation.

The relative humidity must not exceed 90% non-condensing at temperatures of 40□ or less. At temperatures greater than 40□, the wet bulb temperature must not exceed 39□.

Note 1-8: Surface temperature is measured at 50°C dry condition.

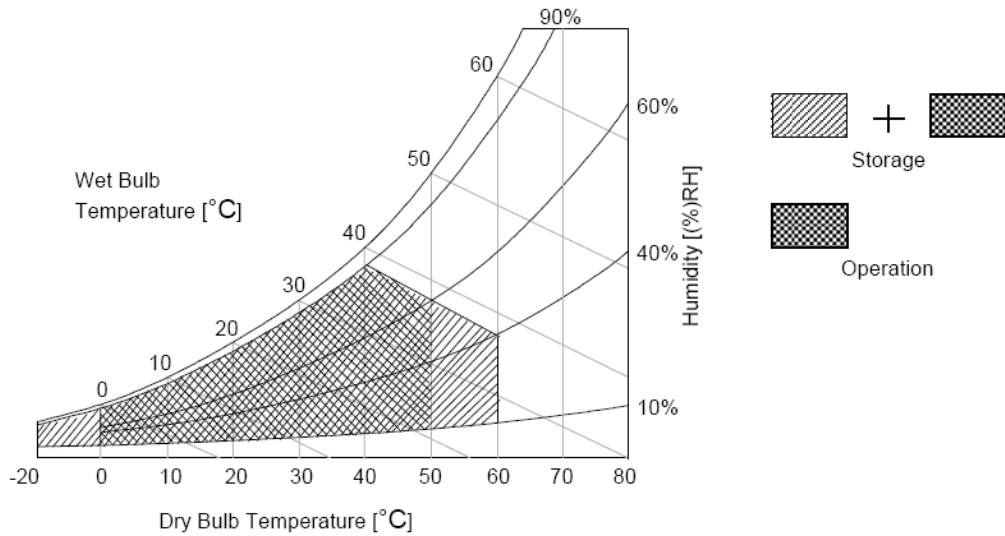

2. Electrical Specification

The P215HAN02.0 requires two power inputs. One is employed to power the LCD electronics and to drive the TFT array and liquid crystal. The other is to power Back Light Unit.

2.1. Block Diagram

The following shows the block diagram of the 21.5 inch Color TFT-LCD Module.

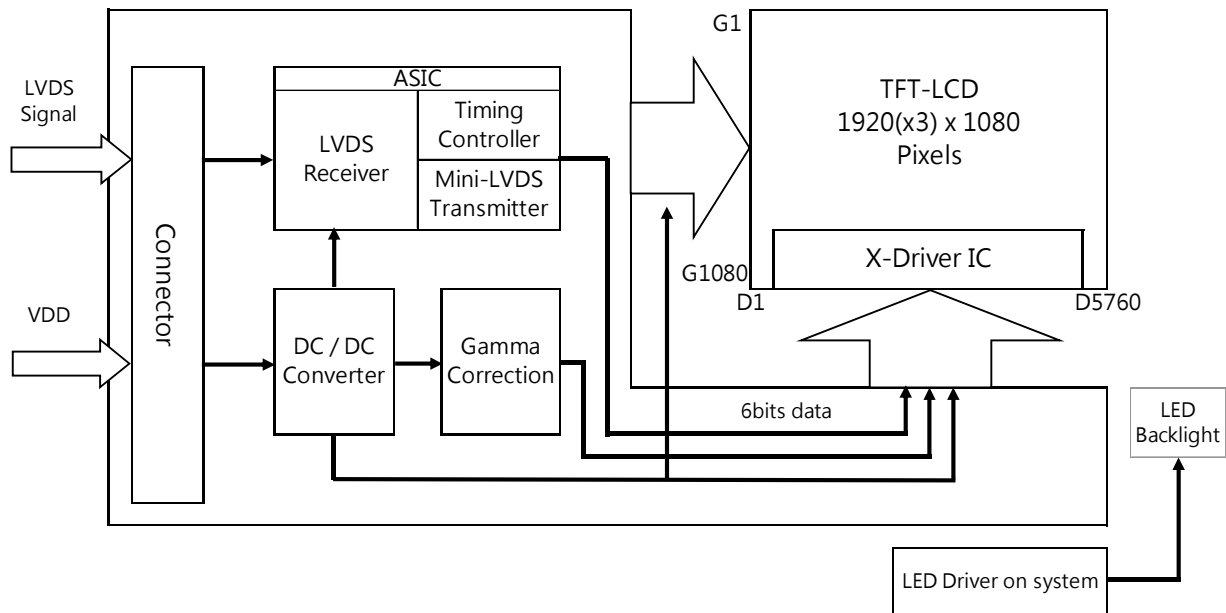

2.2. Interface Connection

2.2.1. Connector Type

TFT-LCD Connector(CN1)	Manufacturer	P-TWO	STM
	Part Number	187034-3009	MSBKT2407P30HB
Mating Connector	Manufacturer	JAE	
	Part Number	FI-X30HL (Locked Type)	

2.2.2. Connector Pin Assignment

PIN #	Symbol	Description	Remark
1	RxO0-	Negative LVDS differential data input (Odd data)	
2	RxO0+	Positive LVDS differential data input (Odd data)	
3	RxO1-	Negative LVDS differential data input (Odd data)	
4	RxO1+	Positive LVDS differential data input (Odd data)	
5	RxO2-	Negative LVDS differential data input (Odd data)	
6	RxO2+	Positive LVDS differential data input (Odd data)	
7	GND	Ground	
8	RxOCLK-	Negative LVDS differential clock input (Odd clock)	
9	RxOCLK+	Positive LVDS differential clock input (Odd clock)	
10	RxO3-	Negative LVDS differential data input (Odd data)	
11	RxO3+	Positive LVDS differential data input (Odd data)	
12	RxE0-	Negative LVDS differential data input (Even data)	
13	RxE0+	Positive LVDS differential data input (Even data)	
14	GND	Ground	
15	RxE1-	Negative LVDS differential data input (Even data)	
16	RxE1+	Positive LVDS differential data input (Even data)	
17	GND	Ground	
18	RxE2-	Negative LVDS differential data input (Even data)	
19	RxE2+	Positive LVDS differential data input (Even data)	
20	RxECLK-	Negative LVDS differential clock input (Even clock)	
21	RxECLK+	Positive LVDS differential clock input (Even clock)	
22	RxE3-	Negative LVDS differential data input (Even data)	
23	RxE3+	Positive LVDS differential data input (Even data)	
24	GND	Ground	
25	NC	No connection (for AUO test only. Do not connect)	
26	NC	No connection (for AUO test only. Do not connect)	
27	NC	No connection (for AUO test only. Do not connect)	
28	VDD	Power Supply Input Voltage	
29	VDD	Power Supply Input Voltage	
30	VDD	Power Supply Input Voltage	

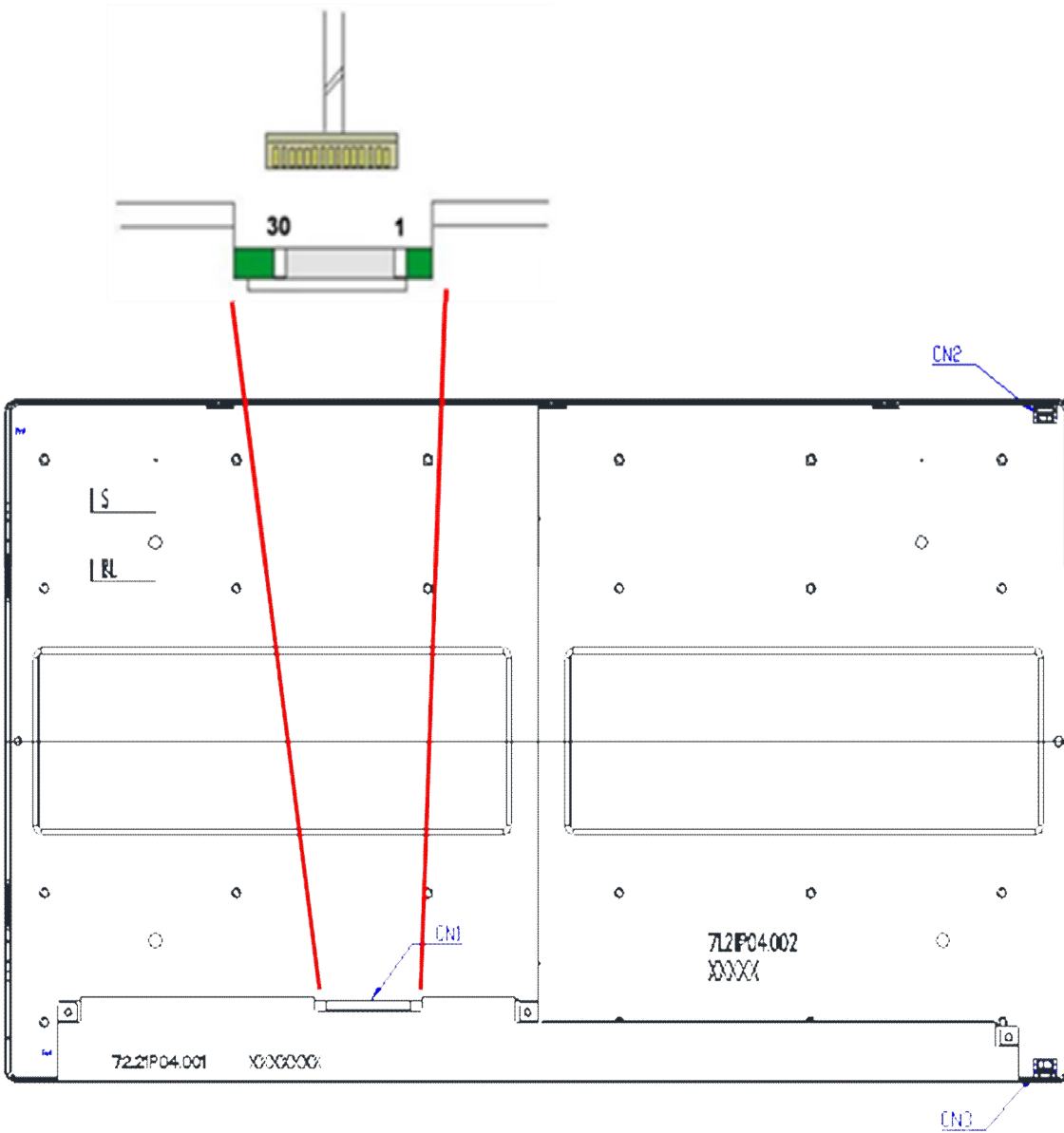

2.3. Electrical Characteristics

2.3.1. Absolute Maximum Rating

Permanent damage may occur if exceeding the following maximum rating.

Symbol	Description	Min	Max	Unit	Remark
VDD	Power Supply Input Voltage	GND-0.3	6.0	[Volt]	Ta=25℃

2.3.2. Recommended Operating Condition

Symbol	Description	Min	Typ	Max	Unit	Remark
VDD	Power supply Input voltage	4.5	5.0	5.5	[Volt]	
IDD	Power supply Input Current (RMS)	-	0.46	0.55	[A]	VDD= 5.0V, All white Pattern, Fv=60Hz
		-	0.50	0.60	[A]	VDD= 5.0V, All white Pattern, Fv=75Hz
PDD	VDD PowerVDD Power Consumption	-	2.30	2.75	[Watt]	VDD= 5.0V, All white Pattern, Fv=60Hz
		-	2.50	3.00	[Watt]	VDD= 5.0V, All white Pattern, Fv=75Hz
IRush	Inrush Current	-	-	3.0	[A]	Note 2-1
VDDrp	Allowable VDD Ripple Voltage	-	-	500	[mV]	VDD= 5.0V, All white Pattern, Fv=75Hz
LTLED	LED Life Time	50,000			[Hours]	Note 2-2

Note 2-1: Inrush Current measurement:

Test circuit:

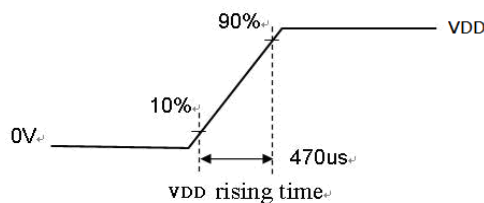
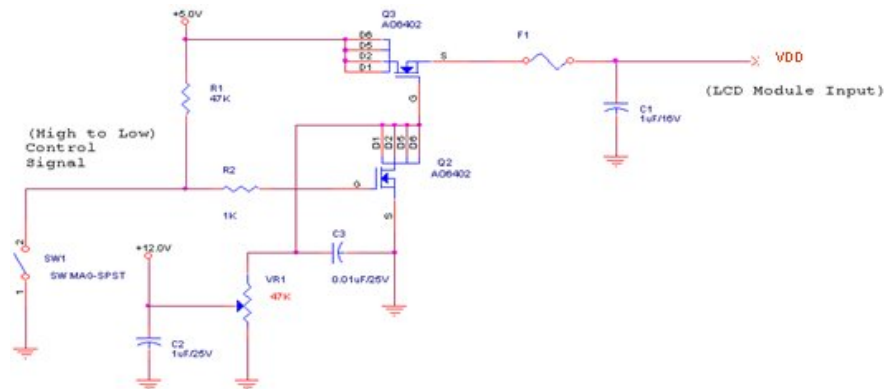

The duration of VDD rising time: 470µs.

Note 2-2: Definition of life time:

- a. Brightness of LED becomes to 50% of its original value
- b. Test condition: $I_s = 47\text{mA}$ and 25°C (Room Temperature)

2.4. Signal Characteristics

2.4.1. LCD Pixel Format

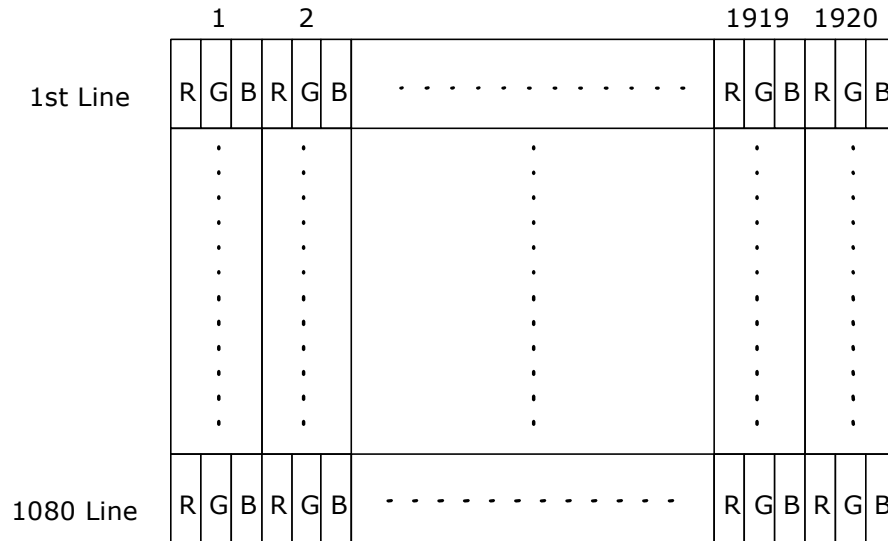

2.4.2. LVDS Data Format

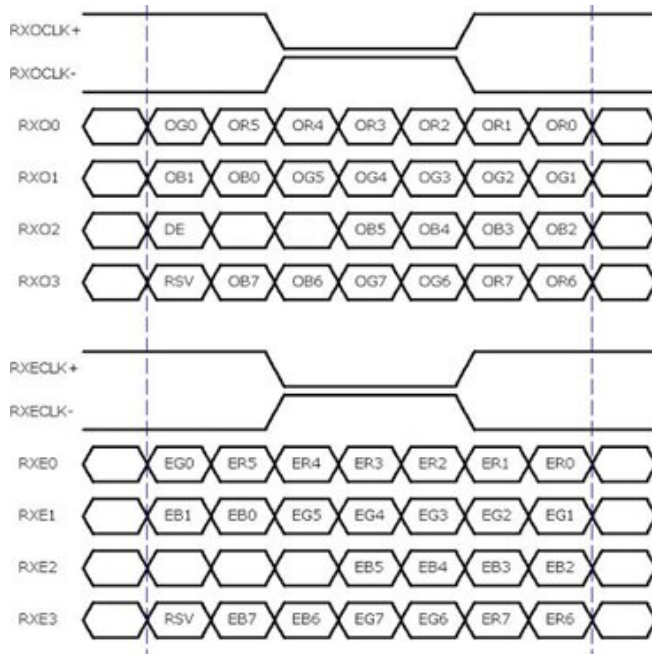

8 Bit Color Bit Order			
MSB	R7	G7	B7
	R6	G6	B6
	R5	G5	B5
	R4	G4	B4
	R3	G3	B3
	R2	G2	B2
	R1	G1	B1
LSB	R0	G0	B0

Note 2-3:

- a. O = "Odd Pixel Data" E = "Even Pixel Data"
- b. Refer to 3.4.1 LCD pixel format, the 1st data is 1 (Odd Pixel Data), the 2nd data is 2 (Even Pixel Data) and the last data is 1920 (Even Pixel Data).

2.4.3. Color versus Input Data

The following table is for color versus input data (8bit). The higher the gray level, the brighter the color.

Color	Gray Level	Color Input Data																								Remark
		RED data (MSB:R7, LSB:R0)								GREEN data (MSB:G7, LSB:G0)								BLUE data (MSB:B7, LSB:B0)								
		R7	R6	R5	R4	R3	R2	R1	R0	G7	G6	G5	G4	G3	G2	G1	G0	B7	B6	B5	B4	B3	B2	B1	B0	
Black	-	0	0	0	0	0	0	0	0	0	0	0	0	0	0	0	0	0	0	0	0	0	0	0	0	
White	-	1	1	1	1	1	1	1	1	1	1	1	1	1	1	1	1	1	1	1	1	1	1	1	1	
Gray 127	-	0	1	1	1	1	1	1	1	0	1	1	1	1	1	1	1	0	1	1	1	1	1	1	1	
Red	L0	0	0	0	0	0	0	0	0	0	0	0	0	0	0	0	0	0	0	0	0	0	0	0	0	Black
	:	:	:	:	:	:	:	:	:	:	:	:	:	:	:	:	:	:	:	:	:	:	:	:	:	
	L255	1	1	1	1	1	1	1	1	0	0	0	0	0	0	0	0	0	0	0	0	0	0	0	0	
Green	L0	0	0	0	0	0	0	0	0	0	0	0	0	0	0	0	0	0	0	0	0	0	0	0	0	Black
	:	:	:	:	:	:	:	:	:	:	:	:	:	:	:	:	:	:	:	:	:	:	:	:	:	
	L255	0	0	0	0	0	0	0	0	0	1	1	1	1	1	1	1	0	0	0	0	0	0	0	0	
Blue	L0	0	0	0	0	0	0	0	0	0	0	0	0	0	0	0	0	0	0	0	0	0	0	0	0	Black
	:	:	:	:	:	:	:	:	:	:	:	:	:	:	:	:	:	:	:	:	:	:	:	:	:	
	L255	0	0	0	0	0	0	0	0	0	0	0	0	0	0	0	0	1	1	1	1	1	1	1	1	

2.4.4. LVDS Specification

a. DC Characteristics:

Symbol	Description	Min	Typ	Max	Units	Condition
VTH	LVDS Differential Input High Threshold	-	-	+100	[mV]	VCM = 1.2V
VTL	LVDS Differential Input Low Threshold	-100	-	-	[mV]	VCM = 1.2V
VID	LVDS Differential Input Voltage	100	-	600	[mV]	
VCM	LVDS Common Mode Voltage	+1.0	+1.2	+1.5	[V]	VTH-VTL = 200mV

LVDS Signal Waveform:

Use RxOCLK- & RxOCLK+ as example.

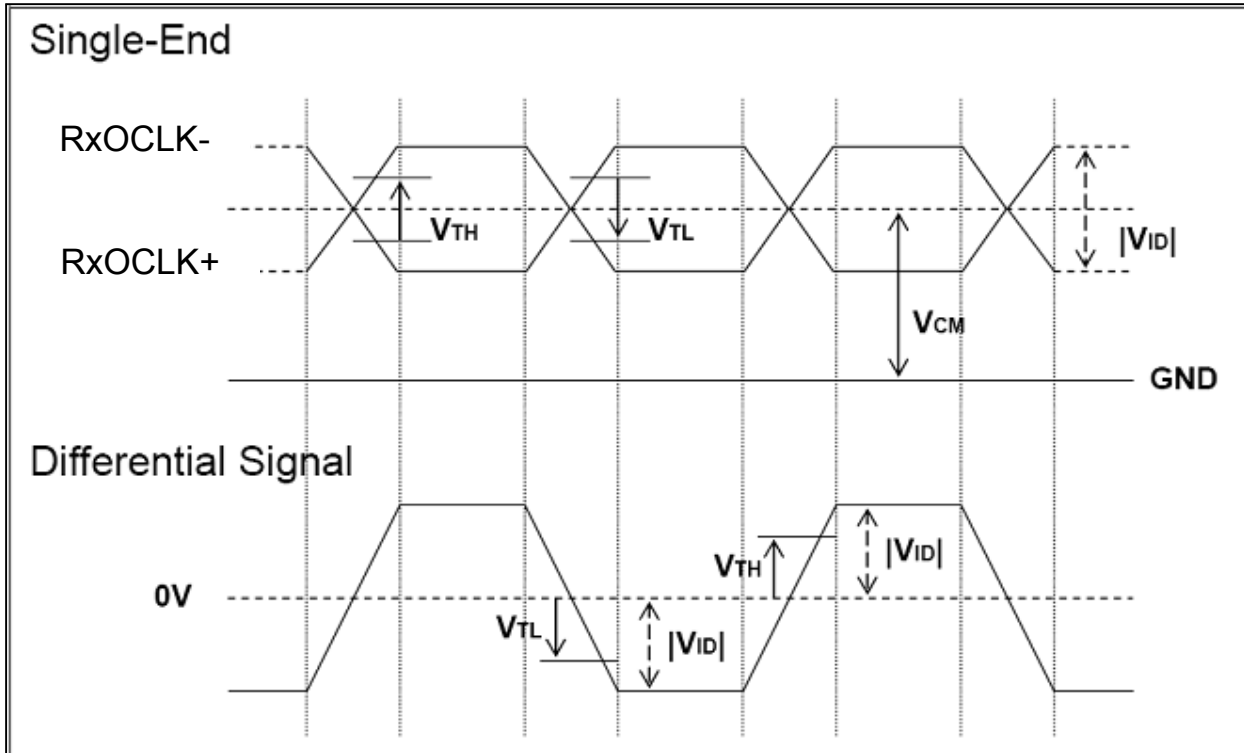

b. AC Characteristics:

Symbol	Description	Min	Max	Unit	Remark
FDEV	Maximum deviation of input clock frequency during Spread Spectrum	-	± 3	%	
FMOD	Maximum modulation frequency of input clock during Spread Spectrum	-	200	KHz	

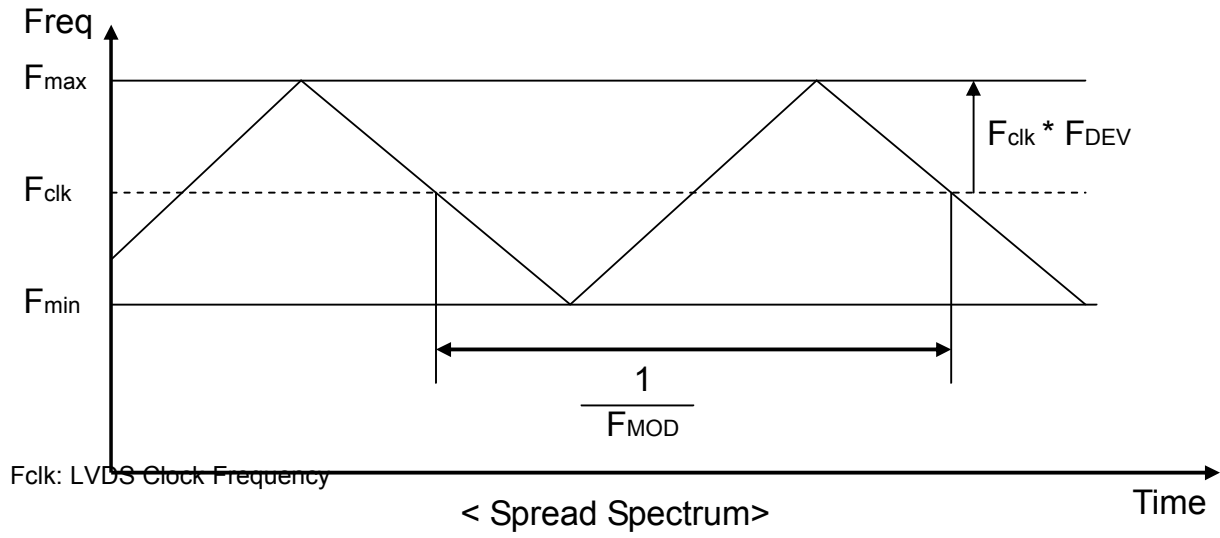

2.4.5. Input Timing Specification

It only support DE mode, and the input timing are shown as the following table.

Symbol	Description		Min.	Typ.	Max.	Unit	Remark
Tv	Vertical Section	Period	1094	1130	1836	Th	
Tdisp (v)		Active	1080	1080	1080	Th	
Tblk (v)		Blanking	14	50	756	Th	
Fv		Frequency	49	60	76	Hz	
Th	Horizontal Section	Period	1000	1050	1678	Tclk	
Tdisp (h)		Active	960	960	960	Tclk	
Tblk (h)		Blanking	40	90	718	Tclk	
Fh		Frequency	53.7	67.8	90.0	KHz	Note 2-4
Tclk	LVDS Clock	Period	11.2	14.0	18.6	ns	1/Fclk
Fclk		Frequency	53.7	71.2	90.0	MHz	Note 2-5

Note 2-4: The equation is listed as following. Please don't exceed the above recommended value.

$$Fh (\text{Min.}) = Fclk (\text{Min.}) / Th (\text{Min.});$$

$$Fh (\text{Typ.}) = Fclk (\text{Typ.}) / Th (\text{Typ.});$$

$$Fh (\text{Max.}) = Fclk (\text{Max.}) / Th (\text{Min.});$$

Note 2-5: The equation is listed as following. Please don't exceed the above recommended value.

$$Fclk (\text{Min.}) = Fv (\text{Min.}) \times Th (\text{Min.}) \times Tv (\text{Min.});$$

$$Fclk (\text{Typ.}) = Fv (\text{Typ.}) \times Th (\text{Typ.}) \times Tv (\text{Typ.});$$

$$Fclk (\text{Max.}) = Fv (\text{Max.}) \times Th (\text{Typ.}) \times Tv (\text{Typ.});$$

2.4.6. Input Timing Diagram

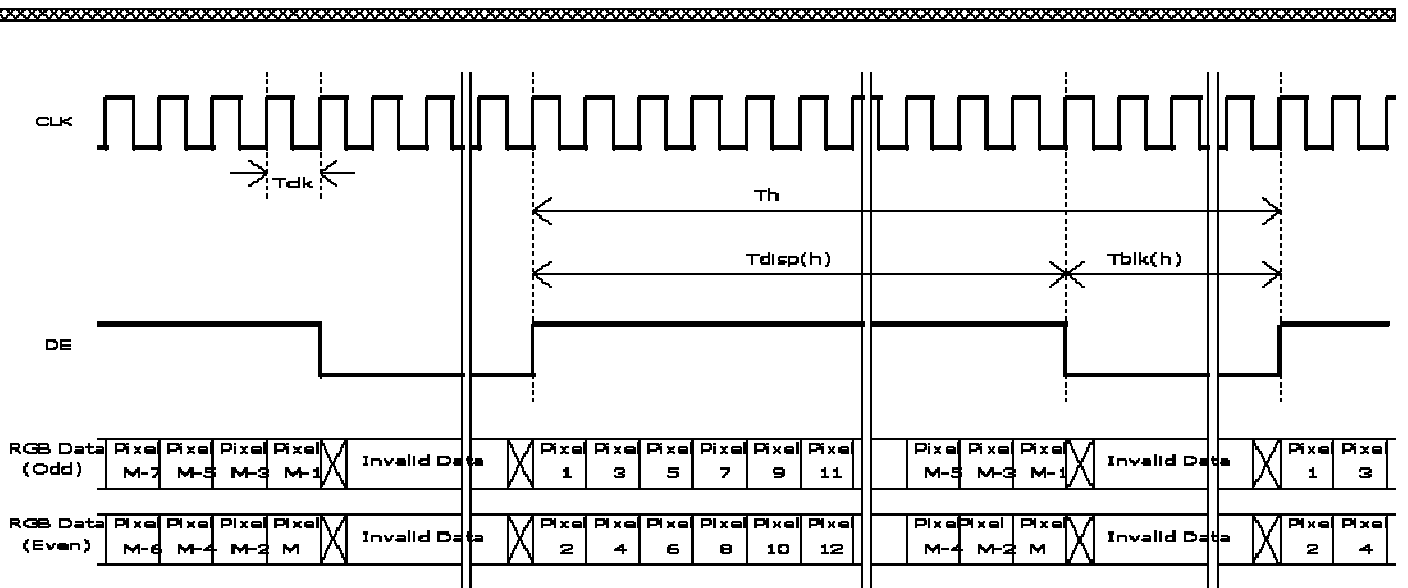
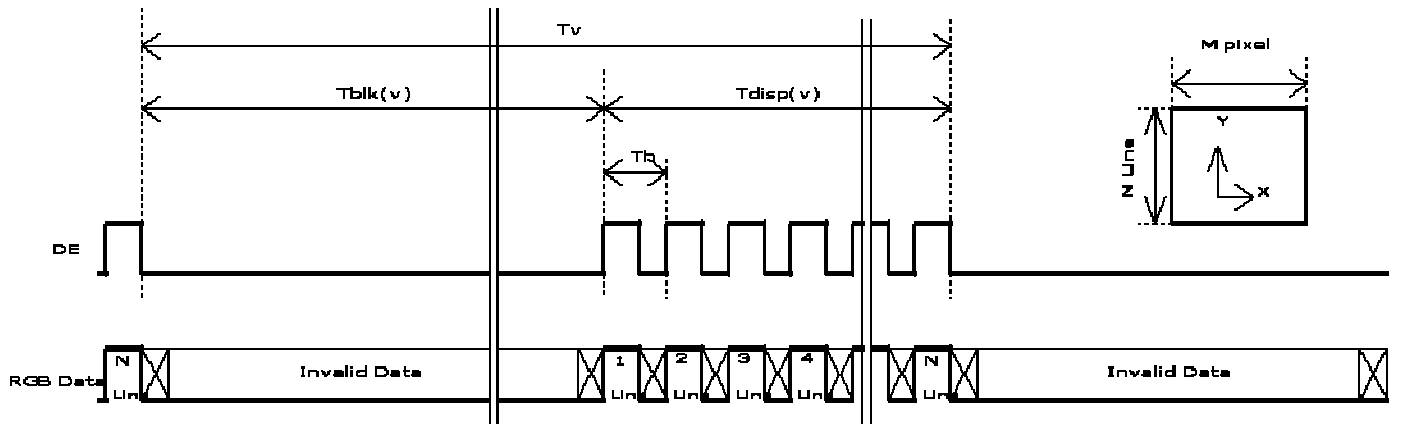

2.5. Power ON/OFF Sequence

VDD power, LVDS signal and backlight on/off sequence are as following. LVDS signals from any system shall be Hi-Z state when VDD is off.

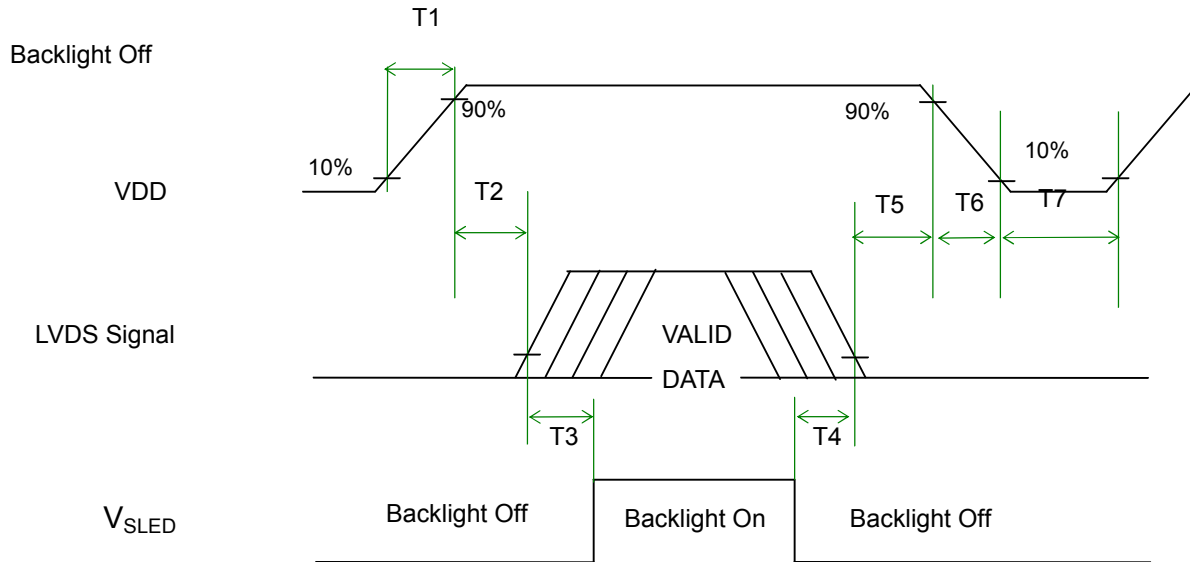

Power Sequence Timing

Symbol	Value			Unit	Remark
	Min.	Typ.	Max.		
T1	0.5	-	10	[ms]	
T2	0	-	50	[ms]	
T3	500	-	-	[ms]	
T4	100	-	-	[ms]	
T5	0		50	[ms]	Note 2-6 Note 2-7
T6	0	-	200	[ms]	Note 2-7 Note 2-8
T7	1000	-	-	[ms]	

Note 2-6 : Recommend setting T5 = 0ms to avoid electronic noise when VDD is off.

Note 2-7 : During T5 and T6 period , please keep the level of input LVDS signals with Hi-Z state.

Note 2-8 : Voltage of VDD must decay smoothly after power-off. (customer system decide this value)

3. Backlight Unit

3.1. Block Diagram

The following shows the block diagram of the 21.5 inch Backlight Unit. And it's included 2pcs of LED light bar in Backlight Unit. Each of LED light bar is included 68 pcs of LED package.(4 strings with 17 pcs LED of each string).

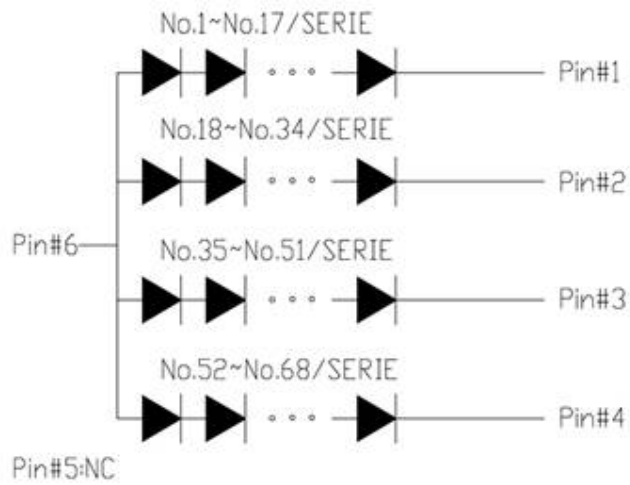

3.2. Interface Connection

3.2.1. Connector Type

Backlight Connector (CN2/CN3)	Manufacturer	CviLux
	Part Number	CI16M1VRA-NH

Mating Connector dimension:

Material:

Base: High temperature plastic UL 94V-0, Color Nature

Contact: Copper alloy

Tab: Copper alloy with Matte Tin plated

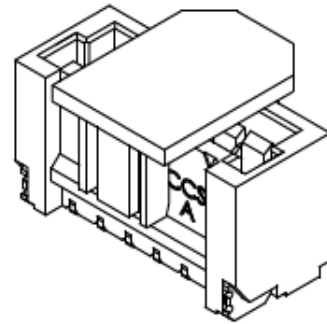
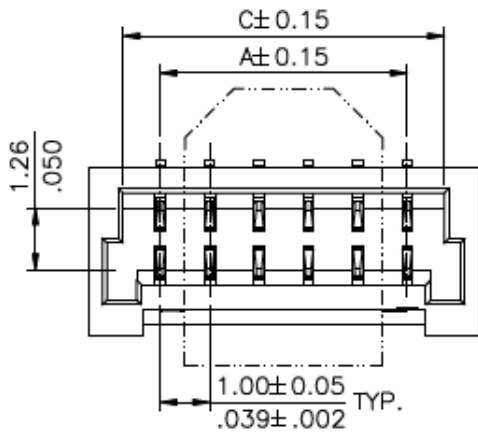

DIM. A = 1.00 x NO. OF SPACES

DIM. B = DIM. A + 2.90

DIM. C = DIM. A + 1.50

* AVAILABLE IN 2 THROUGH 20

3.2.2. Connector Pin Assignment

CN2

LED Lightbar Connector Manufacture			CVILUX:CI1606M1VRA-NH
PIN	SYMBOL	FUNCTION	
1	Vc(1)	LED Cathode (Negative)	
2	Vc(2)	LED Cathode (Negative)	
3	Vc(3)	LED Cathode (Negative)	
4	Vc(4)	LED Cathode (Negative)	
5	NC	NC	
6	Va(1)	LED Anode (Positive)	

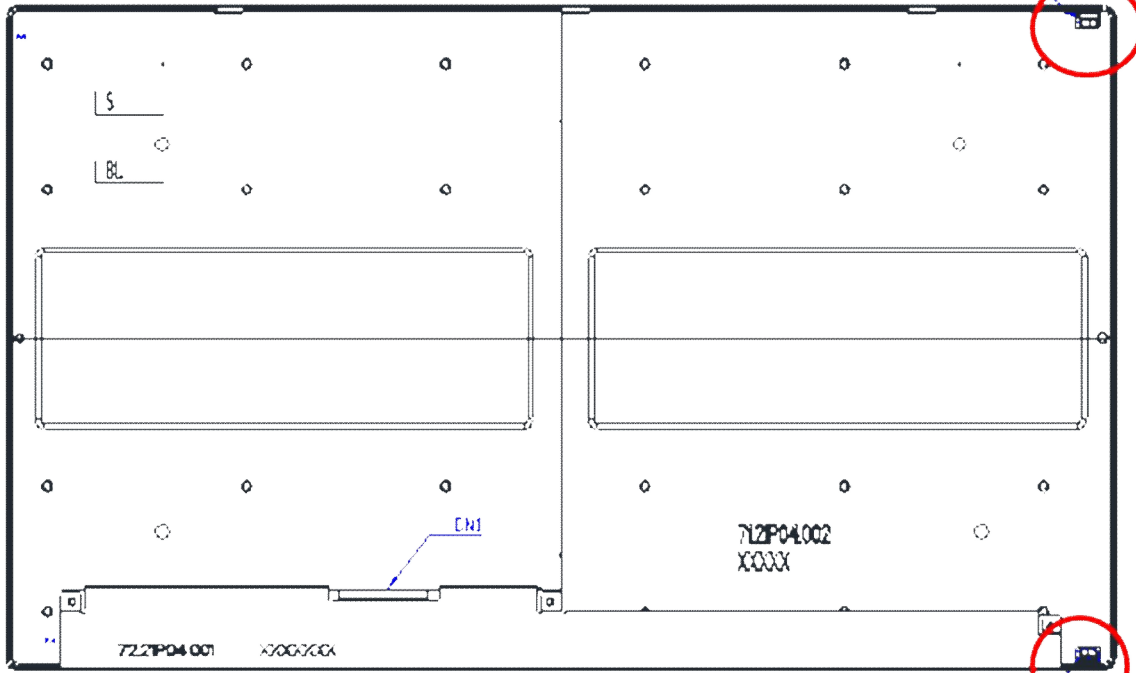

CN3

LED Lightbar Connector Manufacture			CVILUX:CI1606M1VRA-NH
PIN	SYMBOL	FUNCTION	
1	Vc(1)	LED Cathode (Negative)	
2	Vc(2)	LED Cathode (Negative)	
3	Vc(3)	LED Cathode (Negative)	
4	Vc(4)	LED Cathode (Negative)	
5	NC	NC	
6	Va(1)	LED Anode (Positive)	

3.3. Electrical Characteristics

3.3.1. Absolute Maximum Rating

Permanent damage may occur if exceeding the following maximum rating.

(Ta=25°C)

Symbol	Description	Min	Max	Unit	Remark
Is	LED String Current	0	90	[mA]	100% duty ratio
			120	[mA]	Duty ratio ≤ 10% Pulse time=10 ms

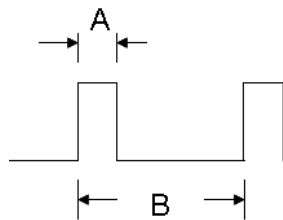

Duty ratio = (A / B) X 100% ; (A: Pulse time, B: Period)

3.3.2. Recommended Operating Condition

(Ta=25°C)

Symbol	Description	Min.	Typ.	Max.	Unit	Remark
Is	LED String Current	-	47	51	[mA]	100% duty ratio of LED chip, Note 3-4
Vs	LED String Voltage	91.8	95.2	109.3	[Volt]	Is=47mA @ 100% duty ratio; Note 3-1
P _{BLU}	LED Light Bar Power Consumption	-	35.8	-	[Watt]	Note 3-2
LT _{LED}	LED Life Time	50,000	-	-	[Hour]	Note 3-3

Note 3-1: $V_s (\text{Typ.}) = V_F (\text{Typ.}) \times \text{LED No. (one string)}$;

- a. V_F : LED chip forward voltage, $V_F (\text{Min.}) = 5.4\text{V}$, $V_F (\text{Typ.}) = 5.6\text{V}$, $V_F (\text{Max.}) = 6.43\text{V}$
- b. The same equation to calculate $V_s (\text{Min.})$ & $V_s (\text{Max.})$ for respective $V_F (\text{Min.})$ & $V_F (\text{Max.})$;

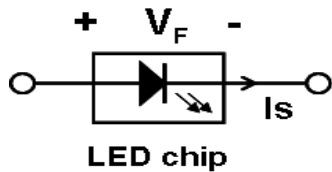

Note 3-2: $P_{\text{BLU}} (\text{Typ.}) = V_s (\text{Typ.}) \times I_s (\text{Typ.}) \times 8$; (8 is total String No. of LED Light bar)

$$P_{\text{BLU}} (\text{Max.}) = V_s (\text{Max.}) \times I_s (\text{Typ.}) \times 8 ;$$

Note 3-3: Definition of life time:

- a. Brightness of LED becomes to 50% of its original value
- b. Test condition: $I_s = 47\text{mA}$ and 25°C (Room Temperature)

Note 3-4: AUO strongly recommend "Analog Dimming" method for backlight brightness control for Wavy Noise Free. Otherwise, recommend that Dimming Control Signal (PWM Signal) should be synchronized with Frame Frequency.

4. Reliability Test Items

AUO reliability test items are listed as following table. (*Bare Panel only*)

	Test Item	Q'ty	Condition
1	High temperature storage test	3	60□, 500hrs
2	Low temperature storage test	3	-20□, 500hrs
3	High temperature operation test	3	50□, 500hrs
4	Low temperature operation test	3	-5□, 500hrs
5	Vibration test (With carton)	1CTN/7PCS	Acceleration: 1.04 Grms Wave: Random. Frequency: 2 - 200 Hz Sweep: 20 Minutes each Axis (X, Y, Z)
6	Drop test (With carton)	1CTN/7PCS	Height: 61cm Direction: 1 Corner-3 Edge-6 Faces (ASTMD4169-I)
7	Vibration test (non-operation)	3	Wave form: random Vibration level : 1.0G RMS Bandwidth : 3-300Hz Duration : X axis, Vertical, 30min Y axis, Vertical, 30min Z axis, Vertical, 30min one time each direction
8	Shock test (non-operation)	3	Shock level 50G ,20ms ±X,Y,Z axis Waveform: half sine wave Direction: One time each direction

5. International Standard

5.1. Safety

- (1) UL 60950-1; Standard for Safety of Information Technology Equipment Including electrical Business Equipment.
- (2) IEC 60950-1; Standard for Safety of International Electrotechnical Commission
- (3) EN 60950-1; European Committee for Electrotechnical Standardization (CENELEC), EUROPEAN STANDARD for Safety of Information Technology Equipment Including Electrical Business Equipment.

5.2. EMC

- (1) ANSI C63.4 "Methods of Measurement of Radio-Noise Emissions from Low-Voltage Electrical and Electrical Equipment in the Range of 9kHz to 40GHz." American National standards Institute(ANSI), 1992
- (2) C.I.S.P.R "Limits and Methods of Measurement of Radio Interface Characteristics of Information Technology Equipment." International Special committee on Radio Interference.
- (3) EN 55022 "Limits and Methods of Measurement of Radio Interface Characteristics of Information Technology Equipment." European Committee for Electrotechnical Standardization. (CENELEC), 1998

6. Packing

6.1. Definition of Label



Green mark description

(1) For Pb Free Product, AUO will add  for identification.

(2) For RoHs compatible products, AUO will add  for identification.

Note: The green Mark will be present only when the green documents have been ready by AUO internal green team. (definition of green design follows the AUO green design checklist.)

6.2. Packing Methods

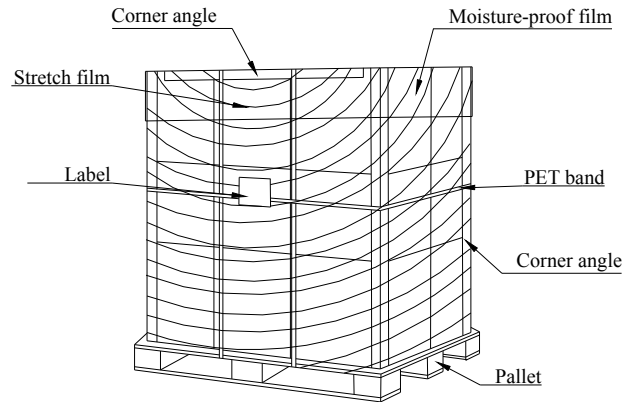
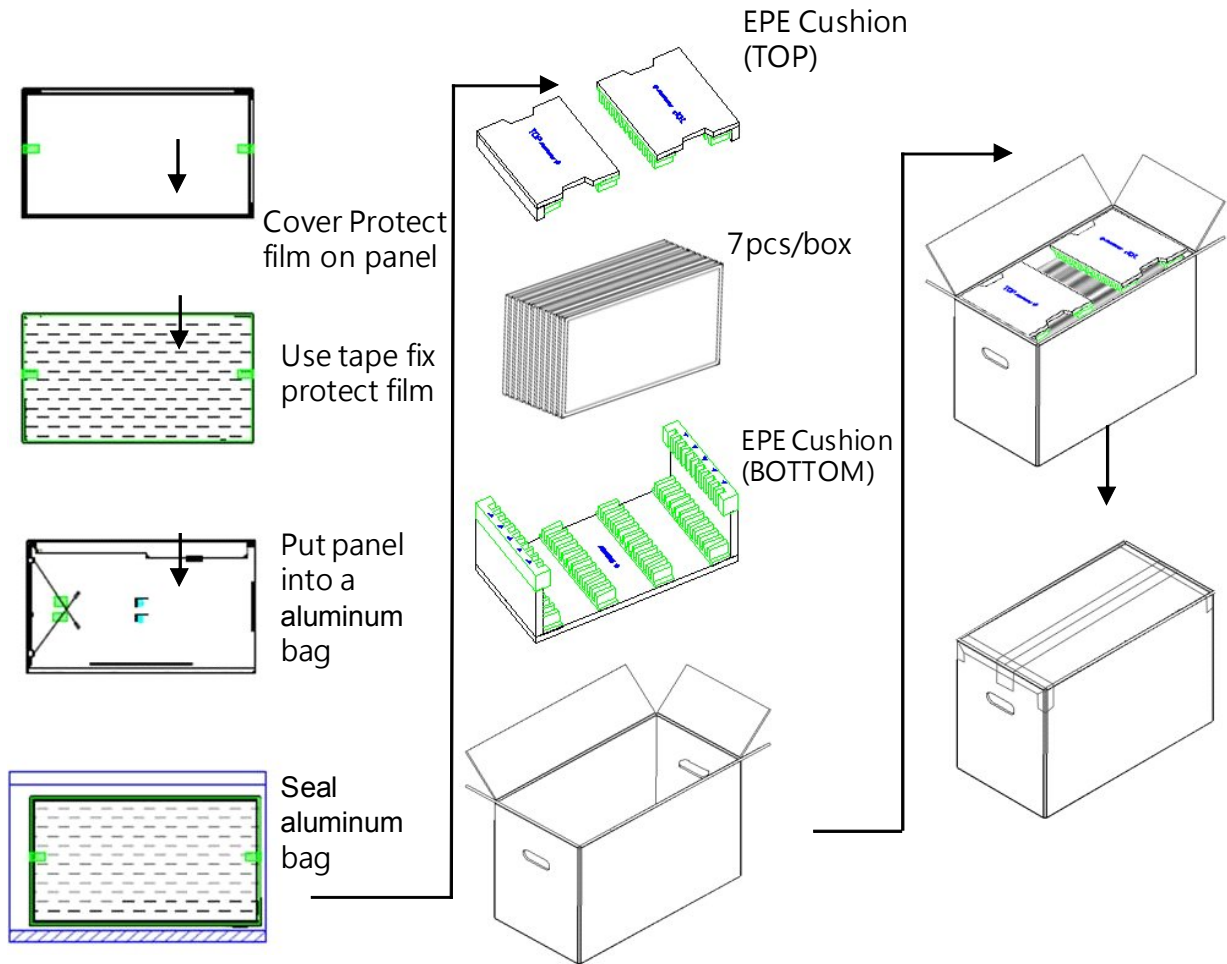

Pallet and Shipment Information

	Item	Specification			Remark
		Q'ty	Dimension	Weight(kg)	
1	Panel	1	501.1mm(H) × 292.2mm(V) × 16.3(D)mm	2.1	Note 1
2	Cushion	1	-	0.55	
3	Box	1	564(L)mm x 300(W)mm x 393(H)mm	1.40	without Panel & cushion Note 1
4	Packing Box	7 pcs/Box	564 (L)mm x 300 (W)mm x 393 (H)mm	16.57	with panel & cushion Note 1
5	Pallet	1	1150(L)mm x 910(W)mm x 132(H)mm	13.8	Note 1
6	Pallet after Packing	18 boxes/pallet	1150(L)mm x 910(W)mm x 1311(H)mm	321.1	Note 1

Note 1: Estimated value which is subject to change based on real measured data.

7. Precautions

Please pay attention to the followings when you use this TFT LCD module.

7.1. Mounting Precautions

- (1) You must mount a module using holes arranged in four corners or four sides.
- (2) You should consider the mounting structure so that uneven force (ex. twisted stress) is not applied to module. And the case on which a module is mounted should have sufficient strength so that external force is not transmitted directly to the module.
- (3) Please attach the surface transparent protective plate to the surface in order to protect the polarizer. Transparent protective plate should have sufficient strength in order to resist external force.
- (4) You should adopt radiation structure to satisfy the temperature specification.
- (5) Acetic acid type and chlorine type materials for the cover case are not desirable because the former generates corrosive gas of attacking the polarizer at high temperature and the latter cause circuit broken by electro-chemical reaction.
- (6) Do not touch, push or rub the exposed polarizer with glass, tweezers or anything harder than HB pencil lead. And please do not rub with dust clothes with chemical treatment. Do not touch the surface of polarizer for bare hand or greasy cloth. (Some cosmetics are detrimental to the polarizer.)
- (7) When the surface becomes dusty, please wipe gently with absorbent cotton or other soft materials like chamois soaks with petroleum benzene. Normal-hexane is recommended for cleaning the adhesives used to attach front/ rear polarizer. Do not use acetone, toluene and alcohol because they cause chemical damage to the polarizer.
- (8) Wipe off saliva or water drops as soon as possible. Their long time contact with polarizer causes deformations and color fading.
- (9) Do not open the case because inside circuits do not have sufficient strength.

7.2. Operating Precautions

- (1) The spike noise causes the mis-operation of circuits. It should be lower than following voltage: $V=\pm 200\text{mV}$ (Over and under shoot voltage)
- (2) Response time depends on the temperature. (In lower temperature, it becomes longer.)
- (3) Brightness depends on the temperature. (In lower temperature, it may become lower.) And in lower temperature, response time (required time that brightness is stable after turned on) becomes longer.
- (4) Be careful for condensation at sudden temperature change. Condensation makes damage to polarizer or electrical contacted parts. And after fading condensation, smear or spot will occur.
- (5) When fixed patterns are displayed for a long time, remnant image is likely to occur.
- (6) Module has high frequency circuits. Sufficient suppression to the electromagnetic

interference shall be done by system manufacturers. Grounding and shielding methods may be important to minimize the interface.

- (7) The conductive material and signal cables are kept away from LED driver inductor to prevent abnormal display, sound noise and temperature rising.

7.3. Operating Condition for Public Information Display

The device listed in the product specification is designed and manufactured for PID (Public Information Display) application. To optimize module's lifetime and function, below operating usages are required.

(1) Normal operating condition

- A. Operating temperature: 0~50°C
- B. Operating humidity: 10~90%
- C. Display pattern: dynamic pattern (Real display).

Note) Long-term static display would cause image sticking.

(2) Operation usage to protect against image sticking due to long-term static display.

- A. Suitable operating time: under 16 hours a day.
- B. Liquid Crystal refresh time is required. Cycling display between 5 minutes' information (static) display and 10 seconds' moving image.
- C. Periodically change background and character (image) color.
- D. Avoid combination of background and character with large different luminance.

(3) Periodically adopt one of the following actions after long time display.

- A. Running the screen saver (motion picture or black pattern)
- B. Power off the system for a while

(4) LCD system is required to place in well-ventilated environment. Adapting active cooling system is highly recommended.

(5) Product reliability and functions are only guaranteed when the product is used under right operation usages. If product will be used in extreme conditions, such as high temperature/humidity, display stationary patterns, or long operation time etc..., it is strongly recommended to contact AUO for filed application engineering advice. Otherwise, its reliability and function may not be guaranteed. Extreme conditions are commonly found at airports, transit stations, banks, stock market and controlling systems.

7.4. Electrostatic Discharge Control

Since a module is composed of electronic circuits, it is not strong to electrostatic discharge. Make certain that treatment persons are connected to ground through wristband etc. And don't touch interface pin directly.

7.5. Precautions for Strong Light Exposure

1. Strong light exposure causes degradation of polarizer and color filter.
2. To keep display function well as a digital signage application, especially the component of TFT is very sensitive to sunlight, it is necessary to set up blocking device protecting panel from radiation of ambient environment.

7.6. Storage

When storing modules as spares for a long time, the following precautions are necessary.

- (1) Store them in a dark place. Do not expose the module to sunlight or fluorescent light. Keep the temperature between 5°C and 35°C at normal humidity.
- (2) The polarizer surface should not come in contact with any other object. It is recommended that they be stored in the container in which they were shipped.
- (3) Storage condition is guaranteed under packing conditions.
- (4) The phase transition of Liquid Crystal in the condition of the low or high storage temperature will be recovered when the LCD module returns to the normal condition.

7.7. Handling Precautions for Protection Film

- (1) The protection film is attached to the bezel with a small masking tape. When the protection film is peeled off, static electricity is generated between the film and polarizer. This should be peeled off slowly and carefully by people who are electrically grounded and with well ion-blown equipment or in such a condition, etc.
- (2) When the module with protection film attached is stored for a long time, sometimes there remains a very small amount of glue still on the bezel after the protection film is peeled off.
- (3) You can remove the glue easily. When the glue remains on the bezel or its vestige is recognized, please wipe them off with absorbent cotton waste or other soft material like chamois soaked with normal-hexane.