

# TFT-DISPLAY DATASHEET

AUO  
Model: M185XTN01.2

## BRIEF SPEC.:

Main Feature Landscape  
White LED Backlight

---

Active Screen Area	409.8 x 230.04 mm)
Diagonal   Format	18.5"   16:9
Resolution	1366 X 768
Colors	262K/16.7M (6 Bit)
Backlight	LED
Brightness	250 cd/m <sup>2</sup>
LED Life Time	30K(h)
Interface	LVDS
Viewing Angle	85/85 L/R 80/80
Touchscreen	No
Power Supply	5 V
Module Outline	430.4 x 254.6 x 9.9 (mm)
Operation Temperature	0 ... +50 °C
Storage Temperature	-20... +60 °C
Surface Treatment	Anti-Glare, Hardness 3H



( ) Preliminary Specification  
(V) Final Specification

<b>Module</b>	18.5" Color TFT-LCD
<b>Model Name</b>	M185XTN01.2 (ES7.0 from 20C)

<b>Customer</b>	<b>Date</b>
_____	_____
<b>Approved by</b>	
_____	_____

<b>Approved by</b>	<b>Date</b>
<u><b>Howard Lee</b></u>	<u>Nov. 14, 2017</u>
<b>Prepared by</b>	<b>Date</b>
<u><b>Cherry Chiu</b></u>	<u>Nov. 14, 2017</u>

Note: This Specification is subject to change without notice.

AU Optronics corporation

## Contents

<b>1 Handling Precautions .....</b>	<b>6</b>
<b>2 General Description .....</b>	<b>7</b>
2.1 Display Characteristics .....	7
2.2 Absolute Maximum Rating of Environment.....	7
2.3 Optical Characteristics.....	9
2.4 Mechanical Characteristics .....	14
<b>3 TFT-LCD Module .....</b>	<b>15</b>
3.1 Block Diagram.....	15
3.2 Interface Connection.....	16
3.2.1 Connector Type .....	16
3.2.2 Connector Pin Assignment.....	16
3.3 Electrical Characteristics.....	18
3.3.1 Absolute Maximum Rating.....	18
3.3.2 Recommended Operating Condition.....	18
3.4 Signal Characteristics .....	18
3.4.1 LCD Pixel Format .....	19
3.4.2 LVDS Data Format.....	19
3.4.3 Color versus Input Data.....	20
3.4.4 LVDS Specification .....	21
3.4.5 Input Timing Specification .....	23
3.4.6 Input Timing Diagram .....	24
3.5 Power ON/OFF Sequence .....	25
<b>4 Backlight Unit .....</b>	<b>26</b>
4.1 Block Diagram.....	26
4.2 Interface Connection.....	27
4.2.1 Connector Type .....	27
4.2.2 Connector Pin Assignment.....	29
4.3 Electrical Characteristics.....	30
4.3.1 Absolute Maximum Rating.....	30
4.3.2 Recommended Operating Condition.....	30
<b>5 Reliability Test.....</b>	<b>32</b>
<b>6 Shipping Label.....</b>	<b>33</b>
<b>7 Mechanical Characteristics .....</b>	<b>34</b>
<b>8 Packing Specification .....</b>	<b>37</b>
8.1 Packing Flow .....	37
8.2 Pallet and shipment information .....	38
<b>9 Design Guide for System .....</b>	<b>38</b>

## Record of Revision

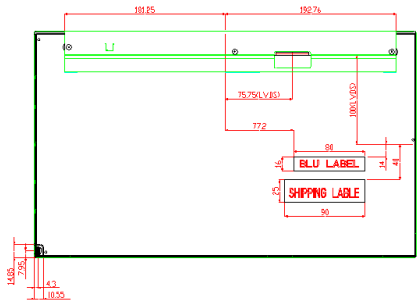
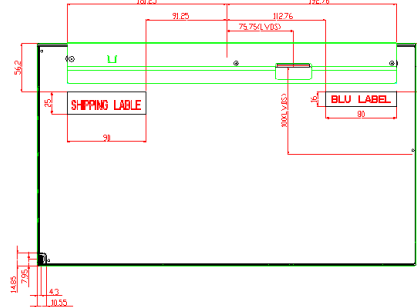
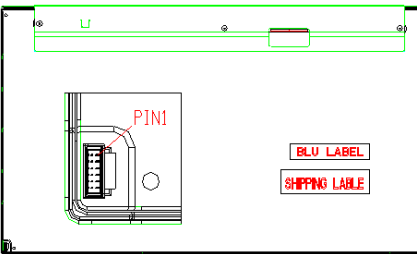
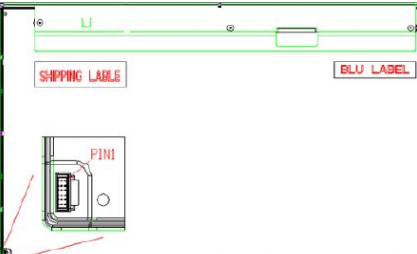
Version Date	Page	Old description	New Description	Remark																																																												
0.1 2012/05/09		Preliminary Version																																																														
0.2 2012/6/18	31	Update label positions. 																																																														
	11	Logic/LCD Drive Voltage VDD: +5.5V	Logic/LCD Drive Voltage VDD: +6.0V																																																													
	13	5.1.1 Power specification Irush Max. :2A	5.1.1 Power specification Irush Max. : TBD																																																													
0.3 2012/7/4	26																																																															
	6	"Energy Star 6.0 Compliance" : Yes	Remove "Energy Star 6.0 Compliance" because it'll be tested not with panel only but completed set.																																																													
	28	Altitude test: Operation 15,000ft	Altitude test: Operation 18,000ft																																																													
0.3 2012/7/9	6	Color / Chromaticity Coordinates (CIE) <table border="1" data-bbox="430 1575 844 1680"> <thead> <tr> <th></th> <th>Red x<sup>o</sup></th> <th>TBD<sup>o</sup></th> <th>TBD<sup>o</sup></th> <th>TBD<sup>o</sup></th> </tr> </thead> <tbody> <tr> <td>Red y<sup>o</sup></td> <td>TBD<sup>o</sup></td> <td>TBD<sup>o</sup></td> <td>TBD<sup>o</sup></td> <td>TBD<sup>o</sup></td> </tr> <tr> <td>Green x<sup>o</sup></td> <td>TBD<sup>o</sup></td> <td>TBD<sup>o</sup></td> <td>TBD<sup>o</sup></td> <td>TBD<sup>o</sup></td> </tr> <tr> <td>Green y<sup>o</sup></td> <td>TBD<sup>o</sup></td> <td>TBD<sup>o</sup></td> <td>TBD<sup>o</sup></td> <td>TBD<sup>o</sup></td> </tr> <tr> <td>Blue x<sup>o</sup></td> <td>TBD<sup>o</sup></td> <td>TBD<sup>o</sup></td> <td>TBD<sup>o</sup></td> <td>TBD<sup>o</sup></td> </tr> <tr> <td>Blue y<sup>o</sup></td> <td>TBD<sup>o</sup></td> <td>TBD<sup>o</sup></td> <td>TBD<sup>o</sup></td> <td>TBD<sup>o</sup></td> </tr> </tbody> </table>		Red x <sup>o</sup>	TBD <sup>o</sup>	TBD <sup>o</sup>	TBD <sup>o</sup>	Red y <sup>o</sup>	TBD <sup>o</sup>	TBD <sup>o</sup>	TBD <sup>o</sup>	TBD <sup>o</sup>	Green x <sup>o</sup>	TBD <sup>o</sup>	TBD <sup>o</sup>	TBD <sup>o</sup>	TBD <sup>o</sup>	Green y <sup>o</sup>	TBD <sup>o</sup>	TBD <sup>o</sup>	TBD <sup>o</sup>	TBD <sup>o</sup>	Blue x <sup>o</sup>	TBD <sup>o</sup>	TBD <sup>o</sup>	TBD <sup>o</sup>	TBD <sup>o</sup>	Blue y <sup>o</sup>	TBD <sup>o</sup>	TBD <sup>o</sup>	TBD <sup>o</sup>	TBD <sup>o</sup>	Color / Chromaticity Coordinates (CIE) <table border="1" data-bbox="868 1575 1282 1680"> <thead> <tr> <th></th> <th>Red x<sup>o</sup></th> <th>0.616</th> <th>0.646</th> <th>0.676</th> </tr> </thead> <tbody> <tr> <td>Red y<sup>o</sup> <td>0.303 <td>0.333 <td>0.363 <td></td> </td></td></td></td></tr> <tr> <td>Green x<sup>o</sup> <td>0.287 <td>0.317 <td>0.347 <td></td> </td></td></td></td></tr> <tr> <td>Green y<sup>o</sup> <td>0.596 <td>0.625 <td>0.655 <td></td> </td></td></td></td></tr> <tr> <td>Blue x<sup>o</sup> <td>0.124 <td>0.154 <td>0.184 <td></td> </td></td></td></td></tr> <tr> <td>Blue y<sup>o</sup> <td>0.031 <td>0.061 <td>0.091 <td></td> </td></td></td></td></tr> </tbody> </table>		Red x <sup>o</sup>	0.616	0.646	0.676	Red y <sup>o</sup> <td>0.303 <td>0.333 <td>0.363 <td></td> </td></td></td>	0.303 <td>0.333 <td>0.363 <td></td> </td></td>	0.333 <td>0.363 <td></td> </td>	0.363 <td></td>		Green x <sup>o</sup> <td>0.287 <td>0.317 <td>0.347 <td></td> </td></td></td>	0.287 <td>0.317 <td>0.347 <td></td> </td></td>	0.317 <td>0.347 <td></td> </td>	0.347 <td></td>		Green y <sup>o</sup> <td>0.596 <td>0.625 <td>0.655 <td></td> </td></td></td>	0.596 <td>0.625 <td>0.655 <td></td> </td></td>	0.625 <td>0.655 <td></td> </td>	0.655 <td></td>		Blue x <sup>o</sup> <td>0.124 <td>0.154 <td>0.184 <td></td> </td></td></td>	0.124 <td>0.154 <td>0.184 <td></td> </td></td>	0.154 <td>0.184 <td></td> </td>	0.184 <td></td>		Blue y <sup>o</sup> <td>0.031 <td>0.061 <td>0.091 <td></td> </td></td></td>	0.031 <td>0.061 <td>0.091 <td></td> </td></td>	0.061 <td>0.091 <td></td> </td>	0.091 <td></td>		
	Red x <sup>o</sup>	TBD <sup>o</sup>	TBD <sup>o</sup>	TBD <sup>o</sup>																																																												
Red y <sup>o</sup>	TBD <sup>o</sup>	TBD <sup>o</sup>	TBD <sup>o</sup>	TBD <sup>o</sup>																																																												
Green x <sup>o</sup>	TBD <sup>o</sup>	TBD <sup>o</sup>	TBD <sup>o</sup>	TBD <sup>o</sup>																																																												
Green y <sup>o</sup>	TBD <sup>o</sup>	TBD <sup>o</sup>	TBD <sup>o</sup>	TBD <sup>o</sup>																																																												
Blue x <sup>o</sup>	TBD <sup>o</sup>	TBD <sup>o</sup>	TBD <sup>o</sup>	TBD <sup>o</sup>																																																												
Blue y <sup>o</sup>	TBD <sup>o</sup>	TBD <sup>o</sup>	TBD <sup>o</sup>	TBD <sup>o</sup>																																																												
	Red x <sup>o</sup>	0.616	0.646	0.676																																																												
Red y <sup>o</sup> <td>0.303 <td>0.333 <td>0.363 <td></td> </td></td></td>	0.303 <td>0.333 <td>0.363 <td></td> </td></td>	0.333 <td>0.363 <td></td> </td>	0.363 <td></td>																																																													
Green x <sup>o</sup> <td>0.287 <td>0.317 <td>0.347 <td></td> </td></td></td>	0.287 <td>0.317 <td>0.347 <td></td> </td></td>	0.317 <td>0.347 <td></td> </td>	0.347 <td></td>																																																													
Green y <sup>o</sup> <td>0.596 <td>0.625 <td>0.655 <td></td> </td></td></td>	0.596 <td>0.625 <td>0.655 <td></td> </td></td>	0.625 <td>0.655 <td></td> </td>	0.655 <td></td>																																																													
Blue x <sup>o</sup> <td>0.124 <td>0.154 <td>0.184 <td></td> </td></td></td>	0.124 <td>0.154 <td>0.184 <td></td> </td></td>	0.154 <td>0.184 <td></td> </td>	0.184 <td></td>																																																													
Blue y <sup>o</sup> <td>0.031 <td>0.061 <td>0.091 <td></td> </td></td></td>	0.031 <td>0.061 <td>0.091 <td></td> </td></td>	0.061 <td>0.091 <td></td> </td>	0.091 <td></td>																																																													
0.4 2012/8/6	12	Revise "VDD min." 4.1 TFT LCD Module <sup>o</sup> <table border="1" data-bbox="430 1753 844 1806"> <thead> <tr> <th>Item<sup>o</sup></th> <th>Symbol<sup>o</sup></th> <th>Min<sup>o</sup></th> <th>Max<sup>o</sup></th> <th>Unit<sup>o</sup></th> <th>Conditions<sup>o</sup></th> </tr> </thead> <tbody> <tr> <td>Logic/LCD Drive Voltage<sup>o</sup></td> <td>VDD<sup>o</sup></td> <td>0<sup>o</sup></td> <td>+6.0<sup>o</sup></td> <td>[Volt]<sup>o</sup></td> <td>Note 1,2<sup>o</sup></td> </tr> </tbody> </table>	Item <sup>o</sup>	Symbol <sup>o</sup>	Min <sup>o</sup>	Max <sup>o</sup>	Unit <sup>o</sup>	Conditions <sup>o</sup>	Logic/LCD Drive Voltage <sup>o</sup>	VDD <sup>o</sup>	0 <sup>o</sup>	+6.0 <sup>o</sup>	[Volt] <sup>o</sup>	Note 1,2 <sup>o</sup>	<table border="1" data-bbox="868 1690 1282 1753"> <thead> <tr> <th>Item<sup>o</sup></th> <th>Symbol<sup>o</sup></th> <th>Min<sup>o</sup></th> <th>Max<sup>o</sup></th> <th>Unit<sup>o</sup></th> <th>Conditions<sup>o</sup></th> </tr> </thead> <tbody> <tr> <td>Logic/LCD Drive Voltage<sup>o</sup></td> <td>VDD<sup>o</sup></td> <td>-0.3<sup>o</sup></td> <td>+6.0<sup>o</sup></td> <td>[Volt]<sup>o</sup></td> <td>Note 1,2<sup>o</sup></td> </tr> </tbody> </table>	Item <sup>o</sup>	Symbol <sup>o</sup>	Min <sup>o</sup>	Max <sup>o</sup>	Unit <sup>o</sup>	Conditions <sup>o</sup>	Logic/LCD Drive Voltage <sup>o</sup>	VDD <sup>o</sup>	-0.3 <sup>o</sup>	+6.0 <sup>o</sup>	[Volt] <sup>o</sup>	Note 1,2 <sup>o</sup>																																					
	Item <sup>o</sup>	Symbol <sup>o</sup>	Min <sup>o</sup>	Max <sup>o</sup>	Unit <sup>o</sup>	Conditions <sup>o</sup>																																																										
Logic/LCD Drive Voltage <sup>o</sup>	VDD <sup>o</sup>	0 <sup>o</sup>	+6.0 <sup>o</sup>	[Volt] <sup>o</sup>	Note 1,2 <sup>o</sup>																																																											
Item <sup>o</sup>	Symbol <sup>o</sup>	Min <sup>o</sup>	Max <sup>o</sup>	Unit <sup>o</sup>	Conditions <sup>o</sup>																																																											
Logic/LCD Drive Voltage <sup>o</sup>	VDD <sup>o</sup>	-0.3 <sup>o</sup>	+6.0 <sup>o</sup>	[Volt] <sup>o</sup>	Note 1,2 <sup>o</sup>																																																											
14	Revise "VDD max." *5.1.1 Power Specification. Input power specifications are as following: <table border="1" data-bbox="430 1879 844 1921"> <thead> <tr> <th>Symbol<sup>o</sup></th> <th>Parameter<sup>o</sup></th> <th>Min<sup>o</sup></th> <th>Typ<sup>o</sup></th> <th>Max<sup>o</sup></th> <th>Unit<sup>o</sup></th> <th>Conditions<sup>o</sup></th> </tr> </thead> <tbody> <tr> <td>VDD<sup>o</sup></td> <td>Logic/LCD Drive Voltage<sup>o</sup></td> <td>4.5<sup>o</sup></td> <td>5.0<sup>o</sup></td> <td>6<sup>o</sup></td> <td>[Volt]<sup>o</sup></td> <td>100%<sup>o</sup></td> </tr> </tbody> </table>	Symbol <sup>o</sup>	Parameter <sup>o</sup>	Min <sup>o</sup>	Typ <sup>o</sup>	Max <sup>o</sup>	Unit <sup>o</sup>	Conditions <sup>o</sup>	VDD <sup>o</sup>	Logic/LCD Drive Voltage <sup>o</sup>	4.5 <sup>o</sup>	5.0 <sup>o</sup>	6 <sup>o</sup>	[Volt] <sup>o</sup>	100% <sup>o</sup>	<table border="1" data-bbox="868 1879 1282 1921"> <thead> <tr> <th>Symbol<sup>o</sup></th> <th>Parameter<sup>o</sup></th> <th>Min<sup>o</sup></th> <th>Typ<sup>o</sup></th> <th>Max<sup>o</sup></th> <th>Unit<sup>o</sup></th> <th>Conditions<sup>o</sup></th> </tr> </thead> <tbody> <tr> <td>VDD<sup>o</sup></td> <td>Logic/LCD Drive Voltage<sup>o</sup></td> <td>4.5<sup>o</sup></td> <td>5.0<sup>o</sup></td> <td>5.5<sup>o</sup></td> <td>[Volt]<sup>o</sup></td> <td>100%<sup>o</sup></td> </tr> </tbody> </table>	Symbol <sup>o</sup>	Parameter <sup>o</sup>	Min <sup>o</sup>	Typ <sup>o</sup>	Max <sup>o</sup>	Unit <sup>o</sup>	Conditions <sup>o</sup>	VDD <sup>o</sup>	Logic/LCD Drive Voltage <sup>o</sup>	4.5 <sup>o</sup>	5.0 <sup>o</sup>	5.5 <sup>o</sup>	[Volt] <sup>o</sup>	100% <sup>o</sup>																																		
Symbol <sup>o</sup>	Parameter <sup>o</sup>	Min <sup>o</sup>	Typ <sup>o</sup>	Max <sup>o</sup>	Unit <sup>o</sup>	Conditions <sup>o</sup>																																																										
VDD <sup>o</sup>	Logic/LCD Drive Voltage <sup>o</sup>	4.5 <sup>o</sup>	5.0 <sup>o</sup>	6 <sup>o</sup>	[Volt] <sup>o</sup>	100% <sup>o</sup>																																																										
Symbol <sup>o</sup>	Parameter <sup>o</sup>	Min <sup>o</sup>	Typ <sup>o</sup>	Max <sup>o</sup>	Unit <sup>o</sup>	Conditions <sup>o</sup>																																																										
VDD <sup>o</sup>	Logic/LCD Drive Voltage <sup>o</sup>	4.5 <sup>o</sup>	5.0 <sup>o</sup>	5.5 <sup>o</sup>	[Volt] <sup>o</sup>	100% <sup>o</sup>																																																										

	24	Revise "Timing Diagram" 																																																																																																																																		
0.5 2012/10/4	23	Revise "Timing Characteristics": <table border="1"> <thead> <tr> <th>Signal</th> <th>Item</th> <th>Symbol</th> <th>Min</th> <th>Typ</th> <th>Max</th> <th>Unit</th> </tr> </thead> <tbody> <tr> <td rowspan="4">V-section</td> <td>Period</td> <td><math>T_p</math></td> <td>776</td> <td>808</td> <td>1023</td> <td>Th</td> </tr> <tr> <td>Active</td> <td><math>T_{disp}(v)</math></td> <td>768</td> <td>768</td> <td>768</td> <td>Th</td> </tr> <tr> <td>Blanking</td> <td><math>T_{blk}(v)</math></td> <td>8</td> <td>40</td> <td>255</td> <td>Th</td> </tr> <tr> <td>Period</td> <td><math>T_p</math></td> <td>1416</td> <td>1606</td> <td>2047</td> <td>Tclk</td> </tr> <tr> <td rowspan="3">H-section</td> <td>Active</td> <td><math>T_{disp}(h)</math></td> <td>1366</td> <td>1366</td> <td>1366</td> <td>Tclk</td> </tr> <tr> <td>Blanking</td> <td><math>T_{blk}(h)</math></td> <td>50</td> <td>240</td> <td>681</td> <td>Tclk</td> </tr> <tr> <td>Period</td> <td><math>T_{clk}</math></td> <td>-</td> <td>12.8</td> <td>-</td> <td>ns</td> </tr> <tr> <td rowspan="2">Clock</td> <td>Frequency</td> <td><math>F_{req}</math></td> <td>55</td> <td>78</td> <td>90</td> <td>MHz</td> </tr> <tr> <td>Frame Rate</td> <td><math>F</math></td> <td>50</td> <td>60</td> <td>75</td> <td>Hz</td> </tr> </tbody> </table>	Signal	Item	Symbol	Min	Typ	Max	Unit	V-section	Period	$T_p$	776	808	1023	Th	Active	$T_{disp}(v)$	768	768	768	Th	Blanking	$T_{blk}(v)$	8	40	255	Th	Period	$T_p$	1416	1606	2047	Tclk	H-section	Active	$T_{disp}(h)$	1366	1366	1366	Tclk	Blanking	$T_{blk}(h)$	50	240	681	Tclk	Period	$T_{clk}$	-	12.8	-	ns	Clock	Frequency	$F_{req}$	55	78	90	MHz	Frame Rate	$F$	50	60	75	Hz	<table border="1"> <thead> <tr> <th>Signal</th> <th>Item</th> <th>Symbol</th> <th>Min</th> <th>Typ</th> <th>Max</th> <th>Unit</th> </tr> </thead> <tbody> <tr> <td rowspan="4">V-section</td> <td>Period</td> <td><math>T_p</math></td> <td>788</td> <td>808</td> <td>1313</td> <td>Th</td> </tr> <tr> <td>Active</td> <td><math>T_{disp}(v)</math></td> <td>768</td> <td>768</td> <td>768</td> <td>Th</td> </tr> <tr> <td>Blanking</td> <td><math>T_{blk}(v)</math></td> <td>20</td> <td>40</td> <td>545</td> <td>Th</td> </tr> <tr> <td>Period</td> <td><math>T_p</math></td> <td>1432</td> <td>1606</td> <td>2047</td> <td>Tclk</td> </tr> <tr> <td rowspan="3">H-section</td> <td>Active</td> <td><math>T_{disp}(h)</math></td> <td>1366</td> <td>1366</td> <td>1366</td> <td>Tclk</td> </tr> <tr> <td>Blanking</td> <td><math>T_{blk}(h)</math></td> <td>66</td> <td>240</td> <td>681</td> <td>Tclk</td> </tr> <tr> <td>Period</td> <td><math>T_{clk}</math></td> <td>10.64</td> <td>12.8</td> <td>17.72</td> <td>ns</td> </tr> <tr> <td rowspan="2">Clock</td> <td>Frequency</td> <td><math>F_{req}</math></td> <td>55</td> <td>78</td> <td>90</td> <td>MHz</td> </tr> <tr> <td>Frame Rate</td> <td><math>F</math></td> <td>50</td> <td>60</td> <td>76</td> <td>Hz</td> </tr> </tbody> </table>	Signal	Item	Symbol	Min	Typ	Max	Unit	V-section	Period	$T_p$	788	808	1313	Th	Active	$T_{disp}(v)$	768	768	768	Th	Blanking	$T_{blk}(v)$	20	40	545	Th	Period	$T_p$	1432	1606	2047	Tclk	H-section	Active	$T_{disp}(h)$	1366	1366	1366	Tclk	Blanking	$T_{blk}(h)$	66	240	681	Tclk	Period	$T_{clk}$	10.64	12.8	17.72	ns	Clock	Frequency	$F_{req}$	55	78	90	MHz	Frame Rate	$F$	50	60	76	Hz	
Signal	Item	Symbol	Min	Typ	Max	Unit																																																																																																																														
V-section	Period	$T_p$	776	808	1023	Th																																																																																																																														
	Active	$T_{disp}(v)$	768	768	768	Th																																																																																																																														
	Blanking	$T_{blk}(v)$	8	40	255	Th																																																																																																																														
	Period	$T_p$	1416	1606	2047	Tclk																																																																																																																														
H-section	Active	$T_{disp}(h)$	1366	1366	1366	Tclk																																																																																																																														
	Blanking	$T_{blk}(h)$	50	240	681	Tclk																																																																																																																														
	Period	$T_{clk}$	-	12.8	-	ns																																																																																																																														
Clock	Frequency	$F_{req}$	55	78	90	MHz																																																																																																																														
	Frame Rate	$F$	50	60	75	Hz																																																																																																																														
Signal	Item	Symbol	Min	Typ	Max	Unit																																																																																																																														
V-section	Period	$T_p$	788	808	1313	Th																																																																																																																														
	Active	$T_{disp}(v)$	768	768	768	Th																																																																																																																														
	Blanking	$T_{blk}(v)$	20	40	545	Th																																																																																																																														
	Period	$T_p$	1432	1606	2047	Tclk																																																																																																																														
H-section	Active	$T_{disp}(h)$	1366	1366	1366	Tclk																																																																																																																														
	Blanking	$T_{blk}(h)$	66	240	681	Tclk																																																																																																																														
	Period	$T_{clk}$	10.64	12.8	17.72	ns																																																																																																																														
Clock	Frequency	$F_{req}$	55	78	90	MHz																																																																																																																														
	Frame Rate	$F$	50	60	76	Hz																																																																																																																														
	7	Revise "Color / Chromaticity Coordinates (CIE)" <table border="1"> <thead> <tr> <th>Green <math>y^*</math></th> <th>0.595</th> <th>0.625</th> <th>0.655</th> </tr> </thead> <tbody> <tr> <td>Green <math>y^*</math></td> <td>0.595</td> <td>0.625</td> <td>0.655</td> </tr> </tbody> </table>	Green $y^*$	0.595	0.625	0.655	Green $y^*$	0.595	0.625	0.655	<table border="1"> <thead> <tr> <th>Green <math>y^*</math></th> <th>0.592</th> <th>0.622</th> <th>0.652</th> </tr> </thead> <tbody> <tr> <td>Green <math>y^*</math></td> <td>0.592</td> <td>0.622</td> <td>0.652</td> </tr> </tbody> </table>	Green $y^*$	0.592	0.622	0.652	Green $y^*$	0.592	0.622	0.652																																																																																																																	
Green $y^*$	0.595	0.625	0.655																																																																																																																																	
Green $y^*$	0.595	0.625	0.655																																																																																																																																	
Green $y^*$	0.592	0.622	0.652																																																																																																																																	
Green $y^*$	0.592	0.622	0.652																																																																																																																																	
	31	Revise max outline thickness Original: $9.8 \pm 0.5$ mm	New: $9.9 \pm 0.5$ mm																																																																																																																																	
	14	Revise Irush current: Max.TBD	<table border="1"> <thead> <tr> <th>Irush</th> <th>Irush Current</th> <th>-</th> <th>-</th> <th>2</th> <th>[A]</th> <th>Note 1</th> </tr> </thead> <tbody> <tr> <td></td> <td></td> <td></td> <td></td> <td></td> <td></td> <td></td> </tr> </tbody> </table>	Irush	Irush Current	-	-	2	[A]	Note 1																																																																																																																										
Irush	Irush Current	-	-	2	[A]	Note 1																																																																																																																														
	27	Revise 7.2 LED Connector on Backlight Unit Part number: 3707K-Q06N-01R	New part number: 3707K-S06N-21R																																																																																																																																	
	12	Revise LED forward Voltage variation <table border="1"> <thead> <tr> <th>LED forward Voltage variation (per string variation)</th> <th><math>\Delta V_f</math></th> <th>-</th> <th>3.4</th> <th>[V]</th> <th>Note 1,2</th> </tr> </thead> <tbody> <tr> <td>LED forward Voltage variation (per string variation)</td> <td><math>\Delta V_f</math></td> <td>-</td> <td>3.4</td> <td>[V]</td> <td>Note 1,2</td> </tr> </tbody> </table>	LED forward Voltage variation (per string variation)	$\Delta V_f$	-	3.4	[V]	Note 1,2	LED forward Voltage variation (per string variation)	$\Delta V_f$	-	3.4	[V]	Note 1,2	<table border="1"> <thead> <tr> <th>LED forward Voltage variation (per string variation)</th> <th><math>\Delta V_f</math></th> <th>-</th> <th>1.6</th> <th>[V]</th> <th>Note 1,2</th> </tr> </thead> <tbody> <tr> <td>LED forward Voltage variation (per string variation)</td> <td><math>\Delta V_f</math></td> <td>-</td> <td>1.6</td> <td>[V]</td> <td>Note 1,2</td> </tr> </tbody> </table>	LED forward Voltage variation (per string variation)	$\Delta V_f$	-	1.6	[V]	Note 1,2	LED forward Voltage variation (per string variation)	$\Delta V_f$	-	1.6	[V]	Note 1,2																																																																																																									
LED forward Voltage variation (per string variation)	$\Delta V_f$	-	3.4	[V]	Note 1,2																																																																																																																															
LED forward Voltage variation (per string variation)	$\Delta V_f$	-	3.4	[V]	Note 1,2																																																																																																																															
LED forward Voltage variation (per string variation)	$\Delta V_f$	-	1.6	[V]	Note 1,2																																																																																																																															
LED forward Voltage variation (per string variation)	$\Delta V_f$	-	1.6	[V]	Note 1,2																																																																																																																															
1.0 Final version		Version code 0.5	Version code 1.0																																																																																																																																	
1.1 2012/12/25	7	Max. Response time: not specified	<table border="1"> <thead> <tr> <th>Response Time</th> <th>[msec]</th> <th>Rising Time (<math>T_{ra}</math>)</th> <th>-</th> <th>3.6</th> <th>5.5</th> <th rowspan="3">4</th> </tr> </thead> <tbody> <tr> <td></td> <td></td> <td>Falling Time (<math>T_{rf}</math>)</td> <td>-</td> <td>1.4</td> <td>2.6</td> </tr> <tr> <td></td> <td></td> <td>Rising + Falling</td> <td>-</td> <td>5</td> <td>8</td> </tr> </tbody> </table>	Response Time	[msec]	Rising Time ( $T_{ra}$ )	-	3.6	5.5	4			Falling Time ( $T_{rf}$ )	-	1.4	2.6			Rising + Falling	-	5	8																																																																																																														
Response Time	[msec]	Rising Time ( $T_{ra}$ )	-	3.6	5.5	4																																																																																																																														
		Falling Time ( $T_{rf}$ )	-	1.4	2.6																																																																																																																															
		Rising + Falling	-	5	8																																																																																																																															
	11	Correct function block diagram input signal annotation 																																																																																																																																		
	11	Remove I/F PCB Interface in this page																																																																																																																																		
	22	Revise LVDS pin 1 annotation "RXIOIN0"	"NC"																																																																																																																																	
	25	Revise Power ON/OFF sequence $T_6$ <table border="1"> <thead> <tr> <th><math>T_6</math></th> <th>5</th> <th>-</th> <th>100</th> <th>[ms]</th> <th>Note 1,2</th> </tr> </thead> <tbody> <tr> <td><math>T_6</math></td> <td>5</td> <td>-</td> <td>100</td> <td>[ms]</td> <td>Note 1,2</td> </tr> </tbody> </table>	$T_6$	5	-	100	[ms]	Note 1,2	$T_6$	5	-	100	[ms]	Note 1,2	<table border="1"> <thead> <tr> <th><math>T_6</math></th> <th>5</th> <th>-</th> <th>150</th> <th>[ms]</th> <th>Note 1,2</th> </tr> </thead> <tbody> <tr> <td><math>T_6</math></td> <td>5</td> <td>-</td> <td>150</td> <td>[ms]</td> <td>Note 1,2</td> </tr> </tbody> </table>	$T_6$	5	-	150	[ms]	Note 1,2	$T_6$	5	-	150	[ms]	Note 1,2																																																																																																									
$T_6$	5	-	100	[ms]	Note 1,2																																																																																																																															
$T_6$	5	-	100	[ms]	Note 1,2																																																																																																																															
$T_6$	5	-	150	[ms]	Note 1,2																																																																																																																															
$T_6$	5	-	150	[ms]	Note 1,2																																																																																																																															
2013/1/17	19	Revise LED current <table border="1"> <thead> <tr> <th>Symbol</th> <th>Description</th> <th>Min.</th> <th>Typ.</th> <th>Max.</th> <th>Unit</th> <th>Note</th> </tr> </thead> <tbody> <tr> <td>ISLED</td> <td>LED Operation Current</td> <td>67</td> <td>70</td> <td>73</td> <td>[mA]</td> <td>Note 1</td> </tr> </tbody> </table>	Symbol	Description	Min.	Typ.	Max.	Unit	Note	ISLED	LED Operation Current	67	70	73	[mA]	Note 1	5.2 Backlight Unit Parameter guideline for LED driving is under stable conditions at 26°C (Room Temperature): <table border="1"> <thead> <tr> <th>Symbol</th> <th>Description</th> <th>Min.</th> <th>Typ.</th> <th>Max.</th> <th>Unit</th> <th>Note</th> </tr> </thead> <tbody> <tr> <td>R_EC1</td> <td>LED Operation Current</td> <td>67</td> <td>70</td> <td>73</td> <td>[mA]</td> <td>Note 1</td> </tr> <tr> <td>R_EC2</td> <td>LED Operation Current</td> <td>67</td> <td>70</td> <td>73</td> <td>[mA]</td> <td>Note 1</td> </tr> <tr> <td>R_EC3</td> <td>LED Operation Current</td> <td>67</td> <td>70</td> <td>73</td> <td>[mA]</td> <td>Note 1</td> </tr> <tr> <td>R_EC4</td> <td>LED Operation Current</td> <td>67</td> <td>70</td> <td>73</td> <td>[mA]</td> <td>Note 1</td> </tr> </tbody> </table>	Symbol	Description	Min.	Typ.	Max.	Unit	Note	R_EC1	LED Operation Current	67	70	73	[mA]	Note 1	R_EC2	LED Operation Current	67	70	73	[mA]	Note 1	R_EC3	LED Operation Current	67	70	73	[mA]	Note 1	R_EC4	LED Operation Current	67	70	73	[mA]	Note 1																																																																																
Symbol	Description	Min.	Typ.	Max.	Unit	Note																																																																																																																														
ISLED	LED Operation Current	67	70	73	[mA]	Note 1																																																																																																																														
Symbol	Description	Min.	Typ.	Max.	Unit	Note																																																																																																																														
R_EC1	LED Operation Current	67	70	73	[mA]	Note 1																																																																																																																														
R_EC2	LED Operation Current	67	70	73	[mA]	Note 1																																																																																																																														
R_EC3	LED Operation Current	67	70	73	[mA]	Note 1																																																																																																																														
R_EC4	LED Operation Current	67	70	73	[mA]	Note 1																																																																																																																														
1.2 2013/09/09	18	5.2.1 Backlight block diagram																																																																																																																																		

	NA		<p><b>ES7.1 Package Block Diagram:</b> The following shows the block diagram of the 18.5 inch Backlight Unit and includes 32 pcs LED in the LED light bar, (4 strings and 8 pcs LED of one string).  </p>																																																																																																																																																							
19	5.2.2 Recommended Operating Condition		<table border="1"> <tr> <td>PBLU</td> <td>BLU Power Consumption</td> <td>6.4</td> <td>7.2</td> <td>7.6</td> <td>[Watt]</td> <td>Note 3</td> </tr> </table>	PBLU	BLU Power Consumption	6.4	7.2	7.6	[Watt]	Note 3																																																																																																																																																
PBLU	BLU Power Consumption	6.4	7.2	7.6	[Watt]	Note 3																																																																																																																																																				
19	Note	<p><b>Note 1:</b> The specified current is 100% duty of LED chip input current. IRLED1,2,3,4 define as per strings LED current.  <b>Note 2:</b> The value showed in the table is one light bar's operation voltage.  <b>Note 3:</b> PBLU = VLED * (IRLED1+IRLED2+IRLED3+IRLED4)  <b>Note 4:</b> Definition of life time: Brightness becomes to 50% of its original value. The minimum life time of LED unit is on the condition of IRLED = 70mA and 25±2°C (Room Temperature).  <b>Note 5:</b> Recommendation for LED driver power design: Due to there are electrical property deviation in LED &amp; monitor set system component after long time operation. AUO strongly recommend the design value of LED driver board OVP (over voltage protection) should be 10% higher than max. value of LED string voltage (Vs) at least.  <b>Note 6:</b> AUO strongly recommend "Analog Dimming" method for backlight brightness control for Way Noise Free. Otherwise, recommend that Dimming Control Signal (PWM Signal) should be synchronized with Frame Frequency.</p>	<p><b>Note 1:</b> The specified current is 100% duty of LED chip input current. Is define as per strings LED current.  <b>Note 2:</b> The value showed is one string operation voltage.  <b>Note 3:</b> PBLU(Typ.) = Vs (Typ.) X Is (Typ.) X 4., (4 is total String No. of LED Light bar).  PBLU(Max.) = Vs (Max.) X Is (Typ.) X 4.  <b>Note 4:</b> Definition of life time: Brightness becomes to 50% of its original value. The minimum life time of LED unit is on the condition of IRLED = 70mA and 25±2°C (Room Temperature).  <b>Note 5:</b> Recommendation for LED driver power design: Due to there are electrical property deviation in LED &amp; monitor set system component after long time operation. AUO strongly recommend the design value of LED driver board OVP (over voltage protection) should be 10% higher than max. value of LED string voltage (Vs) at least.  <b>Note 6:</b> AUO strongly recommend "Analog Dimming" method for backlight brightness control for Way Noise Free. Otherwise, recommend that Dimming Control Signal (PWM Signal) should be synchronized with Frame Frequency.</p>																																																																																																																																																							
23	6.4 Timing Characteristics	<p><b>6.4 Timing Characteristics:</b> Basically, interface timing described here is not actual input timing of LCD module but close to output timing of SN75LVDS205G (Texas Instruments) or equivalent.  <table border="1"> <thead> <tr> <th>Signal</th> <th>Item</th> <th>Symbol</th> <th>Min.</th> <th>Typ.</th> <th>Max.</th> <th>Unit</th> </tr> </thead> <tbody> <tr> <td rowspan="4">V-section</td> <td>Period</td> <td>Tv</td> <td>788</td> <td>808</td> <td>1313</td> <td>Th</td> </tr> <tr> <td>Active</td> <td>Tdisp(v)</td> <td>768</td> <td>768</td> <td>768</td> <td>Th</td> </tr> <tr> <td>Blanking</td> <td>Tbk(v)</td> <td>20</td> <td>40</td> <td>545</td> <td>Th</td> </tr> <tr> <td>Frequency</td> <td>Fv</td> <td>1432</td> <td>1606</td> <td>2047</td> <td>Tclk</td> </tr> <tr> <td rowspan="4">H-section</td> <td>Period</td> <td>Th</td> <td>1366</td> <td>1366</td> <td>1366</td> <td>Tclk</td> </tr> <tr> <td>Active</td> <td>Tdisp(h)</td> <td>66</td> <td>240</td> <td>681</td> <td>Tclk</td> </tr> <tr> <td>Blanking</td> <td>Tbk(h)</td> <td>10.64</td> <td>12.8</td> <td>17.72</td> <td>ns</td> </tr> <tr> <td>Frequency</td> <td>Fh</td> <td>55</td> <td>78</td> <td>90</td> <td>MHz</td> </tr> <tr> <td rowspan="2">Clock</td> <td>Period</td> <td>Tclk</td> <td>10.64</td> <td>12.8</td> <td>17.72</td> <td>ns</td> </tr> <tr> <td>Frequency</td> <td>Fclk</td> <td>57.7</td> <td>77.9</td> <td>94.0</td> <td>MHz</td> </tr> <tr> <td>Frame Rate</td> <td>Frame Rate</td> <td>F</td> <td>50</td> <td>60</td> <td>76</td> <td>Hz</td> </tr> </tbody> </table> <p><b>Note 1:</b> DE mode only.  <b>Note 2:</b> Clock Frequency 90MHz(Max.)= 1416H*1847V*75Hz</p> </p>	Signal	Item	Symbol	Min.	Typ.	Max.	Unit	V-section	Period	Tv	788	808	1313	Th	Active	Tdisp(v)	768	768	768	Th	Blanking	Tbk(v)	20	40	545	Th	Frequency	Fv	1432	1606	2047	Tclk	H-section	Period	Th	1366	1366	1366	Tclk	Active	Tdisp(h)	66	240	681	Tclk	Blanking	Tbk(h)	10.64	12.8	17.72	ns	Frequency	Fh	55	78	90	MHz	Clock	Period	Tclk	10.64	12.8	17.72	ns	Frequency	Fclk	57.7	77.9	94.0	MHz	Frame Rate	Frame Rate	F	50	60	76	Hz	<table border="1"> <thead> <tr> <th>Symbol</th> <th>Description</th> <th>Min.</th> <th>Typ.</th> <th>Max.</th> <th>Unit</th> <th>Remark</th> </tr> </thead> <tbody> <tr> <td rowspan="4">Tv</td> <td rowspan="4">Vertical Section</td> <td>Period</td> <td>793</td> <td>808</td> <td>1293</td> <td>Th</td> <td></td> </tr> <tr> <td>Active</td> <td>768</td> <td>768</td> <td>768</td> <td>Th</td> <td></td> </tr> <tr> <td>Blanking</td> <td>25</td> <td>40</td> <td>525</td> <td>Th</td> <td></td> </tr> <tr> <td>Frequency</td> <td>50</td> <td>60</td> <td>76</td> <td>Hz</td> <td></td> </tr> <tr> <td rowspan="4">Th</td> <td rowspan="4">Horizontal Section</td> <td>Period</td> <td>1454</td> <td>1606</td> <td>2047</td> <td>Tclk</td> <td></td> </tr> <tr> <td>Active</td> <td>1366</td> <td>1366</td> <td>1366</td> <td>Tclk</td> <td></td> </tr> <tr> <td>Blanking</td> <td>88</td> <td>240</td> <td>681</td> <td>Tclk</td> <td></td> </tr> <tr> <td>Frequency</td> <td>39.7</td> <td>48.5</td> <td>64.6</td> <td>KHz</td> <td>Note 1</td> </tr> <tr> <td rowspan="2">Tclk</td> <td rowspan="2">LVDS Clock</td> <td>Period</td> <td>10.6</td> <td>12.8</td> <td>17.3</td> <td>ns</td> <td>1/Fclk</td> </tr> <tr> <td>Frequency</td> <td>57.7</td> <td>77.9</td> <td>94.0</td> <td>MHz</td> <td>Note 2</td> </tr> </tbody> </table> <p><b>Note 1:</b> The equation is listed as following. Please don't exceed the above recommended value.  Fh (Min.) = Fclk (Min.) / Th (Min.);  Fh (Typ.) = Fclk (Typ.) / Th (Typ.);  Fh (Max.) = Fclk (Max.) / Th (Min.);  <b>Note 2:</b> The equation is listed as following. Please don't exceed the above recommended value.  Fclk (Min.) = Fv (Min.) x Th (Min.) x Tv (Min.);  Fclk (Typ.) = Fv (Typ.) x Th (Typ.) x Tv (Typ.);  Fclk (Max.) = Fv (Max.) x Th (Typ.) x Tv (Typ.);</p>	Symbol	Description	Min.	Typ.	Max.	Unit	Remark	Tv	Vertical Section	Period	793	808	1293	Th		Active	768	768	768	Th		Blanking	25	40	525	Th		Frequency	50	60	76	Hz		Th	Horizontal Section	Period	1454	1606	2047	Tclk		Active	1366	1366	1366	Tclk		Blanking	88	240	681	Tclk		Frequency	39.7	48.5	64.6	KHz	Note 1	Tclk	LVDS Clock	Period	10.6	12.8	17.3	ns	1/Fclk	Frequency	57.7	77.9	94.0	MHz	Note 2	
Signal	Item	Symbol	Min.	Typ.	Max.	Unit																																																																																																																																																				
V-section	Period	Tv	788	808	1313	Th																																																																																																																																																				
	Active	Tdisp(v)	768	768	768	Th																																																																																																																																																				
	Blanking	Tbk(v)	20	40	545	Th																																																																																																																																																				
	Frequency	Fv	1432	1606	2047	Tclk																																																																																																																																																				
H-section	Period	Th	1366	1366	1366	Tclk																																																																																																																																																				
	Active	Tdisp(h)	66	240	681	Tclk																																																																																																																																																				
	Blanking	Tbk(h)	10.64	12.8	17.72	ns																																																																																																																																																				
	Frequency	Fh	55	78	90	MHz																																																																																																																																																				
Clock	Period	Tclk	10.64	12.8	17.72	ns																																																																																																																																																				
	Frequency	Fclk	57.7	77.9	94.0	MHz																																																																																																																																																				
Frame Rate	Frame Rate	F	50	60	76	Hz																																																																																																																																																				
Symbol	Description	Min.	Typ.	Max.	Unit	Remark																																																																																																																																																				
Tv	Vertical Section	Period	793	808	1293	Th																																																																																																																																																				
		Active	768	768	768	Th																																																																																																																																																				
		Blanking	25	40	525	Th																																																																																																																																																				
		Frequency	50	60	76	Hz																																																																																																																																																				
Th	Horizontal Section	Period	1454	1606	2047	Tclk																																																																																																																																																				
		Active	1366	1366	1366	Tclk																																																																																																																																																				
		Blanking	88	240	681	Tclk																																																																																																																																																				
		Frequency	39.7	48.5	64.6	KHz	Note 1																																																																																																																																																			
Tclk	LVDS Clock	Period	10.6	12.8	17.3	ns	1/Fclk																																																																																																																																																			
		Frequency	57.7	77.9	94.0	MHz	Note 2																																																																																																																																																			
2.0 2015/12/23	all		<b>ES 7.0 &amp; Modify to follow new format</b>																																																																																																																																																							
7	2.1 Display Characteristics	<table border="1"> <tr> <td>Power Consumption (VDD line + LED line)</td> <td>[Watt]</td> <td>VDD line: PDD (typ)= 1.75W, All black pattern at 60Hz LED line : PBLU (typ) = 7.2W Total : 8.95W</td> </tr> <tr> <td>TCO6.0 Compliance</td> <td></td> <td>Yes</td> </tr> </table>	Power Consumption (VDD line + LED line)	[Watt]	VDD line: PDD (typ)= 1.75W, All black pattern at 60Hz LED line : PBLU (typ) = 7.2W Total : 8.95W	TCO6.0 Compliance		Yes	<p><b>2.1 Display Characteristics</b></p> <table border="1"> <tr> <td>Power Consumption (LCD Module + Backlight unit)</td> <td>[Watt]</td> <td>7.85 (Typ.) LCD module: PDD (Typ.)=1.75 @ Black pattern, Fv=60Hz Backlight unit: PBLU (Typ.)=6.1 @ Ii=70mA</td> </tr> <tr> <td>TCO Compliance</td> <td></td> <td>TCO7.0 Compliance</td> </tr> </table>	Power Consumption (LCD Module + Backlight unit)	[Watt]	7.85 (Typ.) LCD module: PDD (Typ.)=1.75 @ Black pattern, Fv=60Hz Backlight unit: PBLU (Typ.)=6.1 @ Ii=70mA	TCO Compliance		TCO7.0 Compliance																																																																																																																																											
Power Consumption (VDD line + LED line)	[Watt]	VDD line: PDD (typ)= 1.75W, All black pattern at 60Hz LED line : PBLU (typ) = 7.2W Total : 8.95W																																																																																																																																																								
TCO6.0 Compliance		Yes																																																																																																																																																								
Power Consumption (LCD Module + Backlight unit)	[Watt]	7.85 (Typ.) LCD module: PDD (Typ.)=1.75 @ Black pattern, Fv=60Hz Backlight unit: PBLU (Typ.)=6.1 @ Ii=70mA																																																																																																																																																								
TCO Compliance		TCO7.0 Compliance																																																																																																																																																								
26	5.2.1 Backlight block diagram	<p>The following shows the block diagram of the 18.5 inch Backlight Unit. And it includes 32 pcs LED in the LED light bar, (4 strings and 8 pcs LED of one string).</p>	<p><b>4.1 Block Diagram</b></p> <p>The following shows the block diagram of the 18.5 inch Backlight Unit. And it includes 28 pcs LED in the LED light bar, (4 strings and 7 pcs LED of one string).</p>																																																																																																																																																							
30	5.2.2 Recommended Operating Condition	<table border="1"> <thead> <tr> <th>Symbol</th> <th>Description</th> <th>Min.</th> <th>Typ.</th> <th>Max.</th> <th>Unit</th> <th>Note</th> </tr> </thead> <tbody> <tr> <td>IRLED1 IRLED2 IRLED3 IRLED4</td> <td>LED Operation Current</td> <td>-</td> <td>70</td> <td>77</td> <td>[mA]</td> <td>Note 1</td> </tr> <tr> <td>VLED</td> <td>Light Bar Operation Voltage</td> <td>24</td> <td>25.6</td> <td>27.2</td> <td>[Volt]</td> <td>Note 2</td> </tr> <tr> <td>PBLU</td> <td>BLU Power Consumption</td> <td>-</td> <td>7.2</td> <td>7.6</td> <td>[Watt]</td> <td>Note 3</td> </tr> </tbody> </table>	Symbol	Description	Min.	Typ.	Max.	Unit	Note	IRLED1 IRLED2 IRLED3 IRLED4	LED Operation Current	-	70	77	[mA]	Note 1	VLED	Light Bar Operation Voltage	24	25.6	27.2	[Volt]	Note 2	PBLU	BLU Power Consumption	-	7.2	7.6	[Watt]	Note 3	<p><b>4.3.2 Recommended Operating Condition</b></p> <table border="1"> <thead> <tr> <th>Symbol</th> <th>Description</th> <th>Min.</th> <th>Typ.</th> <th>Max.</th> <th>Unit</th> <th>Remark</th> </tr> </thead> <tbody> <tr> <td>I<sub>is</sub></td> <td>LED String Current</td> <td>-</td> <td>70</td> <td>77</td> <td>[mA]</td> <td>100% duty ratio of LED chip</td> </tr> <tr> <td>V<sub>s</sub></td> <td>LED String Voltage</td> <td>19.6</td> <td>21.7</td> <td>23.8</td> <td>[Volt]</td> <td>I<sub>s</sub>=70mA @ 100% duty ratio; Note 4-1, Note 4-5</td> </tr> <tr> <td>ΔV<sub>s</sub></td> <td>Maximum Vs Voltage Deviation of light bar</td> <td>-</td> <td>-</td> <td>1.4</td> <td>[Volt]</td> <td>I<sub>s</sub>=70mA @ 100% duty ratio; Note 4-2</td> </tr> <tr> <td>P<sub>BLU</sub></td> <td>1FD Light Bar Power Consumption</td> <td>-</td> <td>6.1</td> <td>6.7</td> <td>[Watt]</td> <td>Note 4-3</td> </tr> </tbody> </table>	Symbol	Description	Min.	Typ.	Max.	Unit	Remark	I <sub>is</sub>	LED String Current	-	70	77	[mA]	100% duty ratio of LED chip	V <sub>s</sub>	LED String Voltage	19.6	21.7	23.8	[Volt]	I <sub>s</sub> =70mA @ 100% duty ratio; Note 4-1, Note 4-5	ΔV <sub>s</sub>	Maximum Vs Voltage Deviation of light bar	-	-	1.4	[Volt]	I <sub>s</sub> =70mA @ 100% duty ratio; Note 4-2	P <sub>BLU</sub>	1FD Light Bar Power Consumption	-	6.1	6.7	[Watt]	Note 4-3																																																																																								
Symbol	Description	Min.	Typ.	Max.	Unit	Note																																																																																																																																																				
IRLED1 IRLED2 IRLED3 IRLED4	LED Operation Current	-	70	77	[mA]	Note 1																																																																																																																																																				
VLED	Light Bar Operation Voltage	24	25.6	27.2	[Volt]	Note 2																																																																																																																																																				
PBLU	BLU Power Consumption	-	7.2	7.6	[Watt]	Note 3																																																																																																																																																				
Symbol	Description	Min.	Typ.	Max.	Unit	Remark																																																																																																																																																				
I <sub>is</sub>	LED String Current	-	70	77	[mA]	100% duty ratio of LED chip																																																																																																																																																				
V <sub>s</sub>	LED String Voltage	19.6	21.7	23.8	[Volt]	I <sub>s</sub> =70mA @ 100% duty ratio; Note 4-1, Note 4-5																																																																																																																																																				
ΔV <sub>s</sub>	Maximum Vs Voltage Deviation of light bar	-	-	1.4	[Volt]	I <sub>s</sub> =70mA @ 100% duty ratio; Note 4-2																																																																																																																																																				
P <sub>BLU</sub>	1FD Light Bar Power Consumption	-	6.1	6.7	[Watt]	Note 4-3																																																																																																																																																				
2.1 2017/11/14	37-38	8 Packing Specification 14 pcs 裝箱	8 Packing Specification 15 pcs 裝箱																																																																																																																																																							

## 1 Handling Precautions

- 1) Since polarizer is easily damaged, do not touch or press the surface of polarizer with hand.
- 2) Be sure to turn off power supply when inserting or disconnecting from input connector.
- 3) Wipe off water drop immediately. Long contact with water may cause discoloration or spots.
- 4) When the panel surface is soiled, wipe it with absorbent cotton or other soft cloth.
- 5) Since the panel is made of glass, it may break or crack if dropped or bumped on hard surface.
- 6) Since CMOS LSI is used in this module, take care of static electricity and insure human earth when handling.
- 7) Do not open or modify the Module Assembly.
- 8) Do not press the reflector sheet at the back of the module to any directions.
- 9) In case a TFT-LCD Module has to be put back into the packing container slot after once it was taken out from the container, do not press the center of the LED lightbar edge. Otherwise the TFT-LCD Module may be damaged.
- 10) Insert or pull out the interface connector, be sure not to rotate nor tilt it of the TFT-LCD Module.
- 11) Do not twist nor bend the TFT -LCD Module even momentary. It should be taken into consideration that no bending/twisting forces are applied to the TFT-LCD Module from outside. Otherwise the TFT-LCD Module may be damaged.
- 12) Please avoid touching COF position while you are doing mechanical design.
- 13) When storing modules as spares for a long time, the following precaution is necessary: Store them in a dark place. Do not expose the module to sunlight or fluorescent light. Keep the temperature between 5□ and 35□ at normal humidity.
- 14) Do not apply the same pattern for a long time, it will enhance relevant defect.





## 2 General Description

This specification applies to the 18.5 inch wide Color  $\alpha$ -Si TFT-LCD Module M185XTN01.2. The display supports the WXGA - 1366(H) x 768(V) screen format and 16.7M colors (RGB 6-bits + Hi-FRC data). The input interface is one channel LVDS and this module doesn't contain an driver board for backlight.

### 2.1 Display Characteristics

The following items are characteristics summary on the table under 25 $\square$  condition:

ITEMS	Unit	SPECIFICATIONS
Screen Diagonal	[mm]	470.1(18.51")
Active Area	[mm]	409.8 (H) x 230.4 (V)
Pixels H x V	-	1366(x3) x 768
Pixel Pitch	[um]	300 (per one triad) x 300
Pixel Arrangement	-	R.G.B. Vertical Stripe
Display Mode	-	TN Mode, Normally White
White Luminance ( Center )	[cd/m <sup>2</sup> ]	250 cd/m <sup>2</sup> (Typ.)
Contrast Ratio	-	1000 (Typ.)
Color Gamut	-	NTSC 72%
Response Time	[msec]	5 (Typ., on/off)
Power Consumption (LCD Module + Backligh unit)	[Watt]	7.85 (Typ.) LCD module : PDD (Typ.)=1.75 @ Black pattern,Fv=60Hz Backlight unit : P <sub>BLU</sub> (Typ.) =6.1 @Is=70mA
Weight	[Grams]	1290
Outline Dimension	[mm]	430.4 (W) x 254.6 (H) Typ. x 9.9 (D) Typ
Electrical Interface	-	One channel LVDS
Support Color	-	16.7M colors (RGB 6-bit + Hi_FRC )
Surface Treatment	-	Anti-Glare, 3H
Temperature Range		
Operating	[ $^{\circ}$ C]	0 to +50
Storage (Shipping)	[ $^{\circ}$ C]	-20 to +60
RoHS Compliance	-	RoHS Compliance
TCO Compliance	-	TCO 7.0 Compliance

### 2.2 Absolute Maximum Rating of Environment

Permanent damage may occur if exceeding the following maximum rating.





Symbol	Description	Min.	Max.	Unit	Remark
TOP	Operating Temperature	0	+50	[°C]	<b>Note 2-1</b>
TGS	Glass surface temperature (operation)	0	+65	[°C]	<b>Note 2-1</b> Function judged only
HOP	Operation Humidity	5	90	[%RH]	<b>Note 2-1</b>
TST	Storage Temperature	-20	+60	[°C]	
HST	Storage Humidity	5	90	[%RH]	

**Note 2-1:** Temperature and relative humidity range are shown as the below figure.

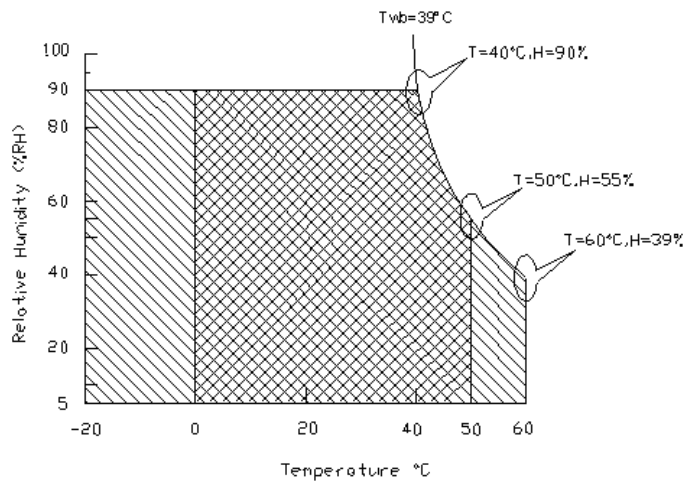
1. 90% RH Max (  $T_a \leq 39^\circ\text{C}$  )
2. Max wet-bulb temperature at  $39^\circ\text{C}$  or less. (  $T_a \leq 39^\circ\text{C}$  )
3. No condensation



Operating Range  Storage Range  + 

## 2.3 Optical Characteristics

The optical characteristics are measured on the following test condition.

### Test Condition:

1. Equipment setup: Please refer to **Note 2-2**.
2. Panel Lighting time: 30 minutes
3. VDD=5.0V, Fv=60Hz, Is=70mA, Ta=25℃

Symbol	Description		Min.	Typ.	Max.	Unit	Remark
L <sub>w</sub>	White Luminance (Center of screen)		200	250	-	[cd/m <sup>2</sup> ]	<b>Note 2-2</b> By SR-3
L <sub>uni</sub>	Luminance Uniformity (9 points)		75	80	-	[%]	<b>Note 2-3</b> By SR-3
CR	Contrast Ratio (Center of screen)		600	1000	-	-	<b>Note 2-4</b> By SR-3
θ <sub>R</sub>	Horizontal Viewing Angle (CR=10)	Right	75	85	-	[degree]	<b>Note 2-5</b> By SR-3
θ <sub>L</sub>		Left	75	85	-		
Φ <sub>H</sub>	Vertical Viewing Angle (CR=10)	Up	70	80	-		
Φ <sub>L</sub>		Down	70	80	-		
θ <sub>R</sub>	Horizontal Viewing Angle (CR=5)	Right	75	88	-		
θ <sub>L</sub>		Left	75	88	-		
Φ <sub>H</sub>	Vertical Viewing Angle (CR=5)	Up	70	85	-		
Φ <sub>L</sub>		Down	70	85	-		
T <sub>R</sub>	Response Time	Rising Time	-	3.6	5.5	[msec]	<b>Note 2-6</b> By TRD-100
T <sub>F</sub>		Falling Time	-	1.4	2.5		
-		Rising + Falling	-	5	8		
R <sub>x</sub>	Color Coordinates (CIE 1931)	Red x	0.616	0.646	0.676	-	By SR-3
R <sub>y</sub>		Red y	0.303	0.333	0.363		
G <sub>x</sub>		Green x	0.287	0.317	0.347		
G <sub>y</sub>		Green y	0.592	0.622	0.652		
B <sub>x</sub>		Blue x	0.124	0.154	0.184		
B <sub>y</sub>		Blue y	0.031	0.061	0.091		
W <sub>x</sub>		White x	0.283	0.313	0.343		
W <sub>y</sub>		White y	0.299	0.329	0.359		
NTSC				72		[%]	By SR-3
CT	Crosstalk		-	-	1.5	[%]	<b>Note 2-7</b> By SR-3
F <sub>dB</sub>	Flicker (Center of screen)		-	-	-20	[dB]	<b>Note 2-8</b> By SR-3

**Note 2-2:** Equipment setup :

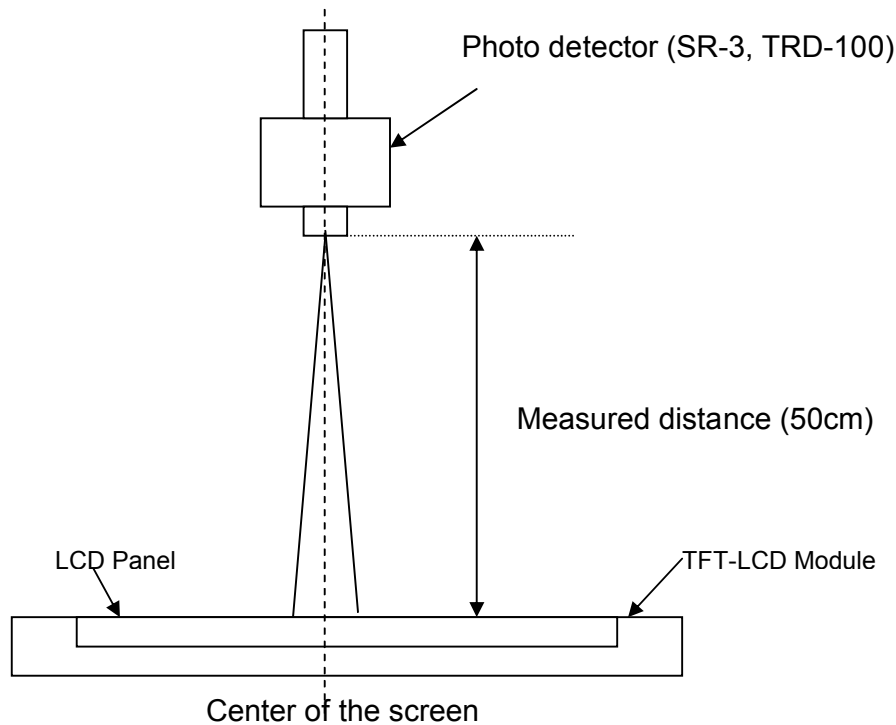

**Note 2-3:** Luminance Uniformity Measurement

**Definition:**

$$\text{Luminance Uniformity} = \frac{\text{Minimum Luminance of 9 Points (P1 ~ P9)}}{\text{Maximum Luminance of 9 Points (P1 ~ P9)}}$$

a. Test pattern: White Pattern

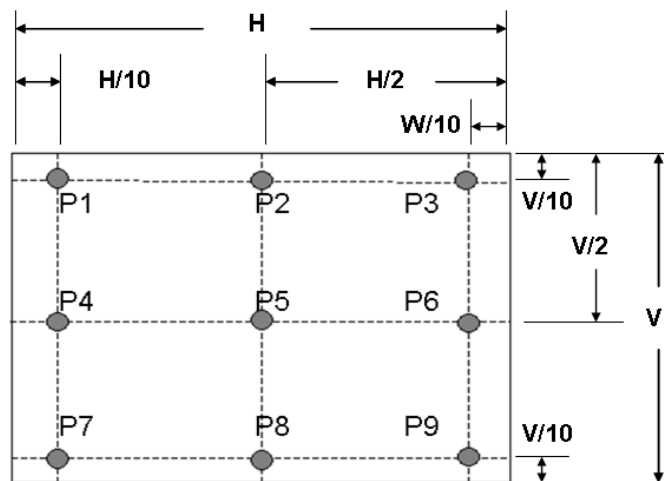

**Note 2-4:** Contrast Ratio Measurement

**Definition:**

$$\text{Contrast Ratio} = \frac{\text{Luminance of White pattern}}{\text{Luminance of Black pattern}}$$

a. Measured position: Center of screen (P5) & perpendicular to the screen  
( $\theta = \Phi = 0^\circ$ )

**Note 2-5:** Viewing angle measurement

**Definition:** The angle at which the contrast ratio is greater than 10 & 5 .

a. Horizontal view angle: Divide to left & right ( $\theta_L$  &  $\theta_R$ )

Vertical view angle: Divide to up & down ( $\Phi_H$  &  $\Phi_L$ )

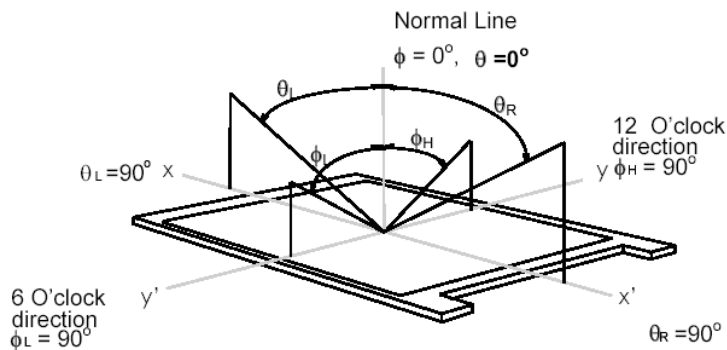

**Note 2-6:** Response time measurement

The output signals of photo detector are measured when the input signals are changed from "Black" to "White" (rising time,  $T_R$ ), and from "White" to "Black" (falling time,  $T_F$ ), respectively. The response time is interval between the 10% and 90% of optical response. (Black & White color definition: Please refer section 3.4.3)

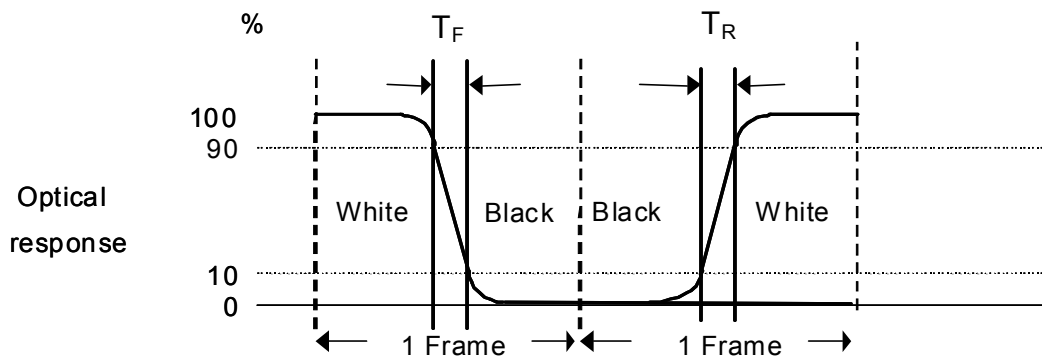

**Note 2-7: Crosstalk measurement**
**Definition:**

$$CT = \text{Max. } (CT_H, CT_V);$$

Where

a. Maximum Horizontal Crosstalk :

$$CT_H = \text{Max. } (| Y_{BL} - Y_{AL} | / Y_{AL} \times 100 \%, | Y_{BR} - Y_{AR} | / Y_{AR} \times 100 \%);$$

Maximum Vertical Crosstalk:

$$CT_V = \text{Max. } (| Y_{BU} - Y_{AU} | / Y_{AU} \times 100 \%, | Y_{BD} - Y_{AD} | / Y_{AD} \times 100 \%);$$

 b.  $Y_{AU}, Y_{AD}, Y_{AL}, Y_{AR}$  = Luminance of measured location without Black pattern

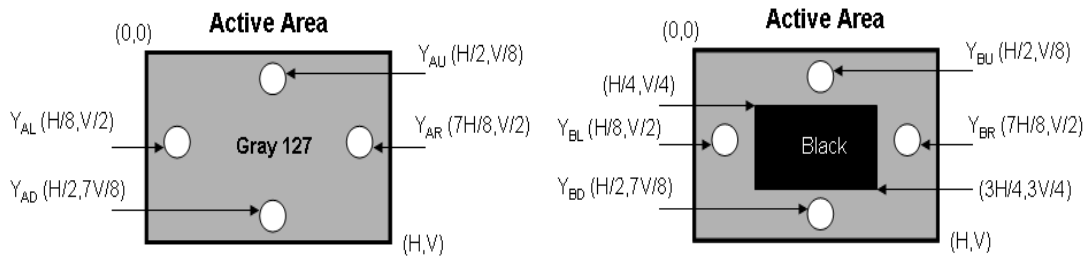
 $Y_{BU}, Y_{BD}, Y_{BL}, Y_{BR}$  = Luminance of measured location with Black pattern

**Note 2-8: Flicker measurement**

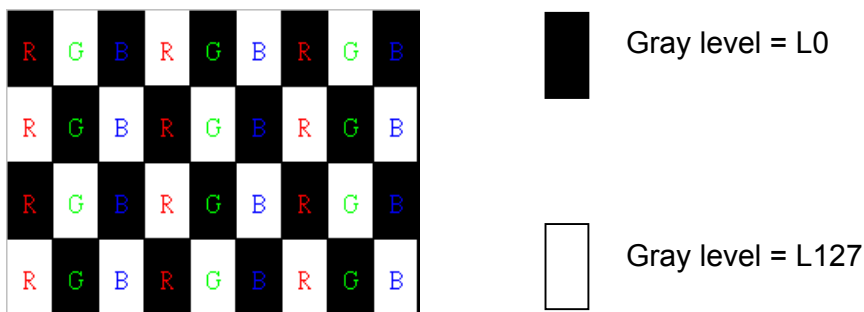
a. Test pattern: It is listed as following.



R: Red, G: Green, B:Blue

 b. Measured position: Center of screen (P5) & perpendicular to the screen  
 $(\theta = \Phi = 0^\circ)$



# Product Specification

M185XTN01.2

AU OPTONICS CORPORATION

## 2.4 Mechanical Characteristics

Symbol	Description	Min.	Max.	Unit	Remark
P <sub>bc</sub>	Backside Compression	2.5	-	[Kgf]	<b>Note 2-9</b>

**Note 2-9:** Test Method:

The point is at a distance from right-downside 25mm x 25mm defined as the Start Point of Measure Points, and the point is at a distance 25mm from left-side & around 10mm from PCB defined as the End Point.

Align 50mm x 50mm block from Start Point on the Bezel Back, and the corners of each block are Measure Points.

If the distance from the last block to each side of the End Point  $\geq 25\text{mm}$ , add other blocks to make sure that most area of Bezel Back can be measured.

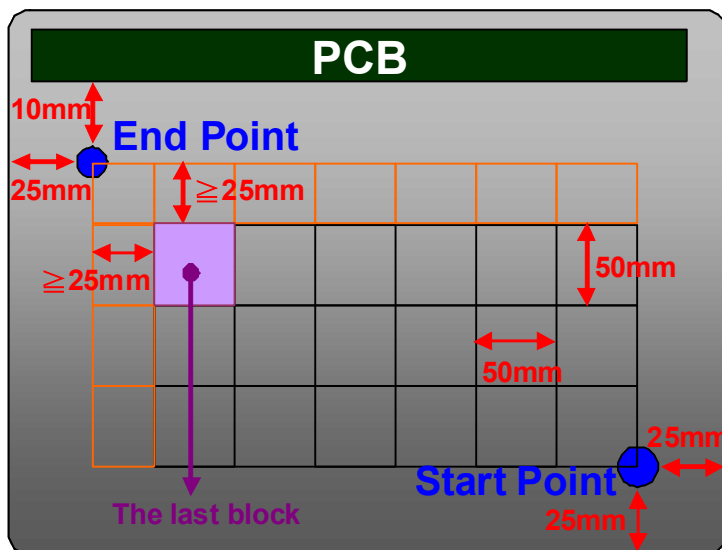



## 3 TFT-LCD Module

### 3.1 Block Diagram

The following shows the block diagram of the 18.5 inch Color TFT-LCD Module.

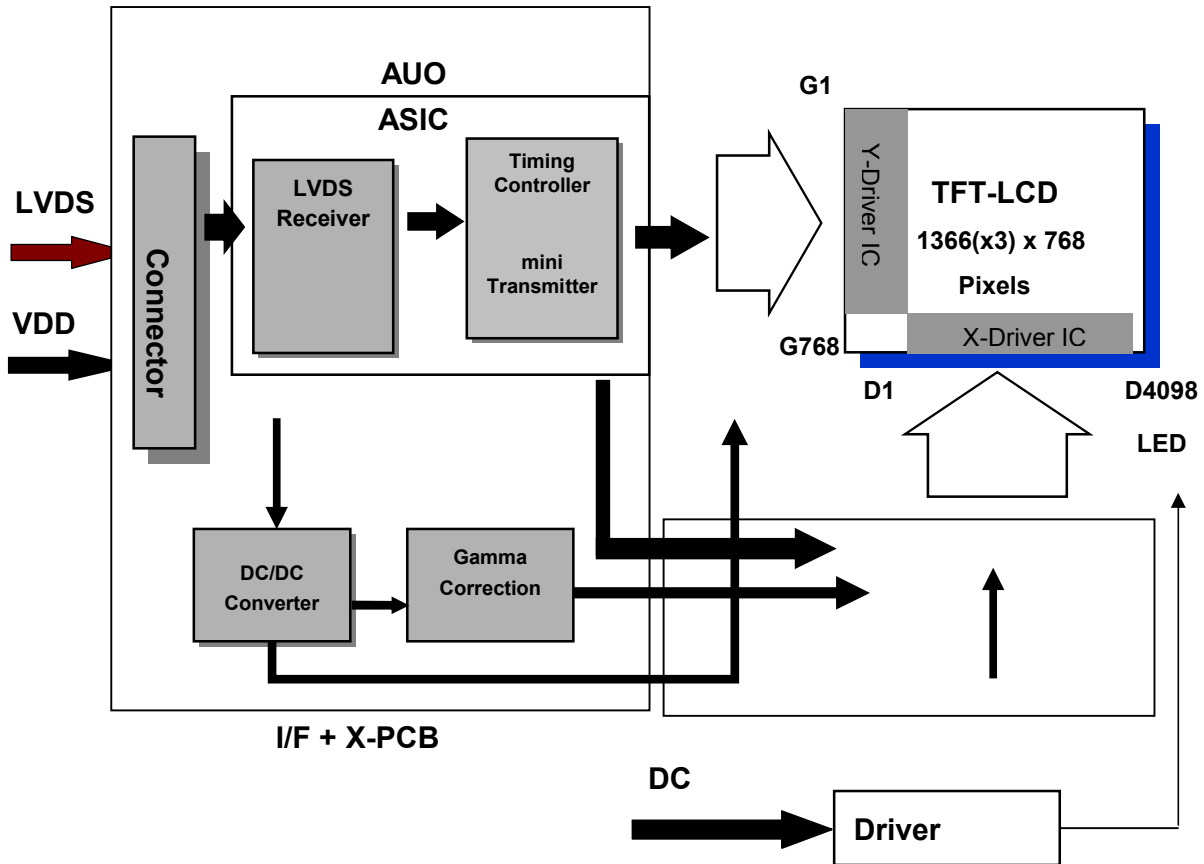

## 3.2 Interface Connection

### 3.2.1 Connector Type

TFT-LCD Connector	Manufacturer	P-TWO	STM
	Part Number	AL230F-A0G1D-P	MSCKT2407P30HB
Mating Connector	Manufacturer	JAE	
	Part Number	FI-X30HL (Locked Type) FI-X30H (Unlocked Type)	

### 3.2.2 Connector Pin Assignment

PIN #	Symbol	Description	Remark
1	NC	No contact (For AUO internal use)	
2	NC	No contact (For AUO internal use)	
3	NC	No contact (For AUO internal use)	
4	GND	Power Ground	
5	RXIN0-	Negative LVDS differential data input (0)	
6	RXIN0+	Positive LVDS differential data input (0)	
7	GND	Power Ground	
8	RXIN1-	Negative LVDS differential data input (1)	
9	RXIN1+	Positive LVDS differential data input (1)	
10	GND	Power Ground	
11	RXIN2-	Negative LVDS differential data input (2)	
12	RXIN2+	Positive LVDS differential data input (2)	
13	GND	Power Ground	
14	RXCLKIN-	Negative LVDS differential clock input (clock)	
15	RXCLKIN+	Positive LVDS differential data input (clock)	
16	GND	Power Ground	
17	RXIN3-	Negative LVDS differential data input (3)	
18	RXIN3+	Positive LVDS differential data input (3)	
19	GND	Power Ground	
20	NC	No contact (For AUO internal use)	
21	NC	No contact (For AUO internal use)	
22	NC	No contact (For AUO internal use)	
23	GND	Power Ground	
24	GND	Power Ground	

25	GND	Power Ground	
26	VDD	+5V power supply	
27	VDD	+5V power supply	
28	VDD	+5V power supply	
29	VDD	+5V power supply	
30	VDD	+5V power supply	

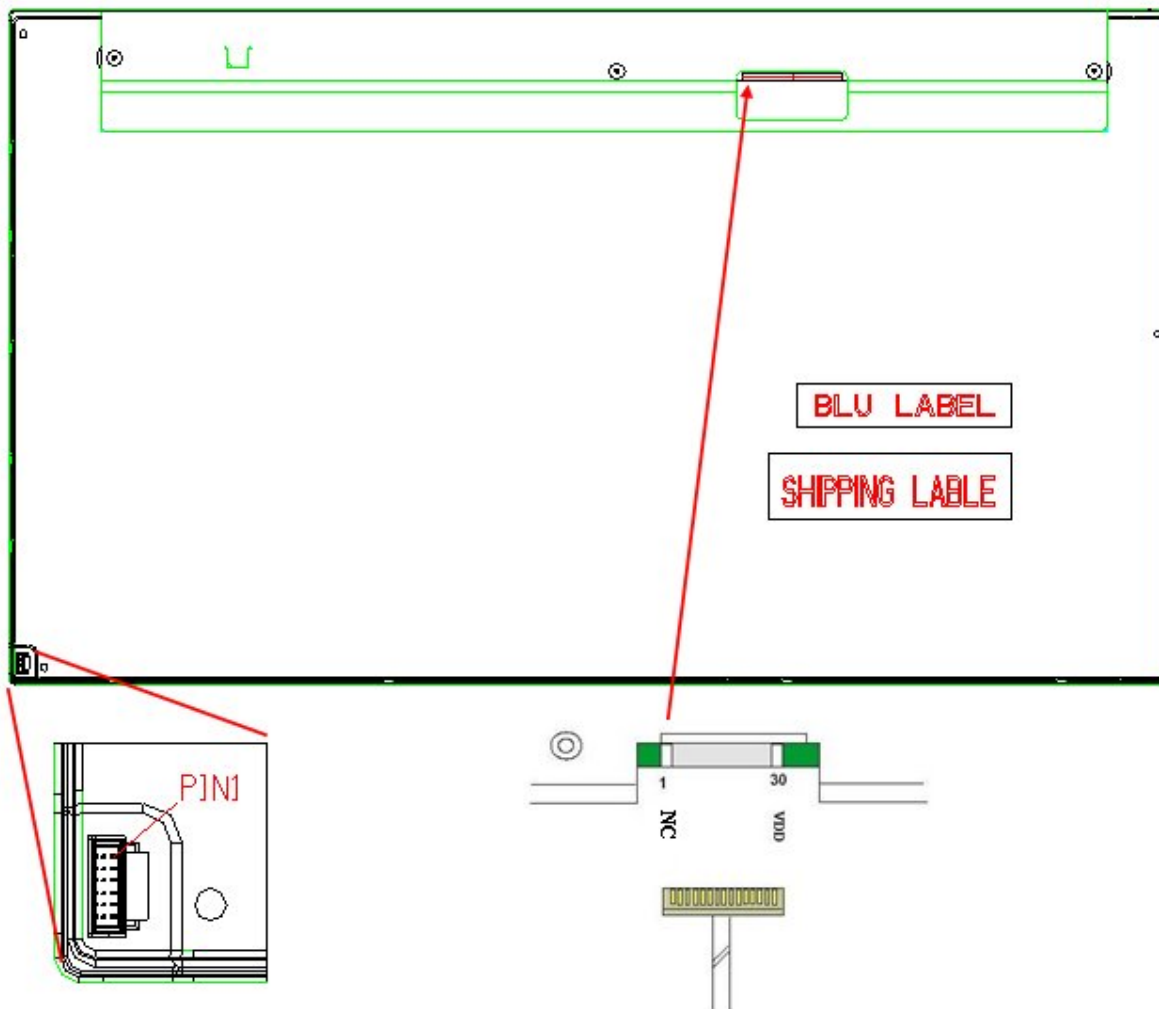

## 3.3 Electrical Characteristics

### 3.3.1 Absolute Maximum Rating

Permanent damage may occur if exceeding the following maximum rating.

Symbol	Description	Min	Max	Unit	Remark
VDD	Power Supply Input Voltage	GND-0.3	6.0	[Volt]	Ta=25□

### 3.3.2 Recommended Operating Condition

Symbol	Description	Min	Typ	Max	Unit	Remark
VDD	Power supply Input voltage	4.5	5.0	5.5	[Volt]	
IDD	Power supply Input Current (RMS)	-	0.35	0.42	[A]	VDD= 5.0V, Black Pattern, Fv=60Hz
			0.42	0.5	[A]	VDD= 5.0V, Black Pattern, Fv=75Hz
PDD	VDD Power Consumption	-	1.75	2.1	[Watt]	VDD= 5.0V, Black Pattern, Fv=60Hz
			2.1	2.5	[Watt]	VDD= 5.0V, Black Pattern, Fv=75Hz
IRush	Inrush Current	-	-	2.0	[A]	<b>Note 3-1</b>
VDDrp	Allowable VDD Ripple Voltage	-	-	350	[mV]	VDD= 5.0V, Black Pattern, Fv=75Hz

**Note 3-1:** Inrush Current measurement:

Test circuit:

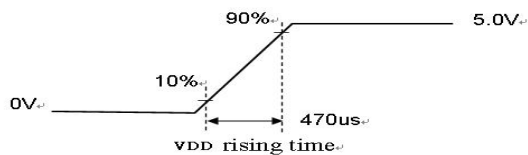
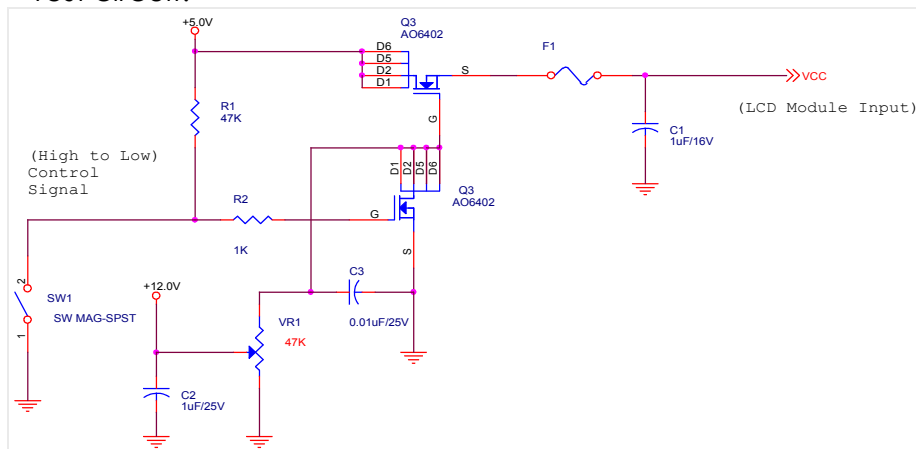

The duration of VDD rising time: 470us.

## 3.4 Signal Characteristics

### 3.4.1 LCD Pixel Format

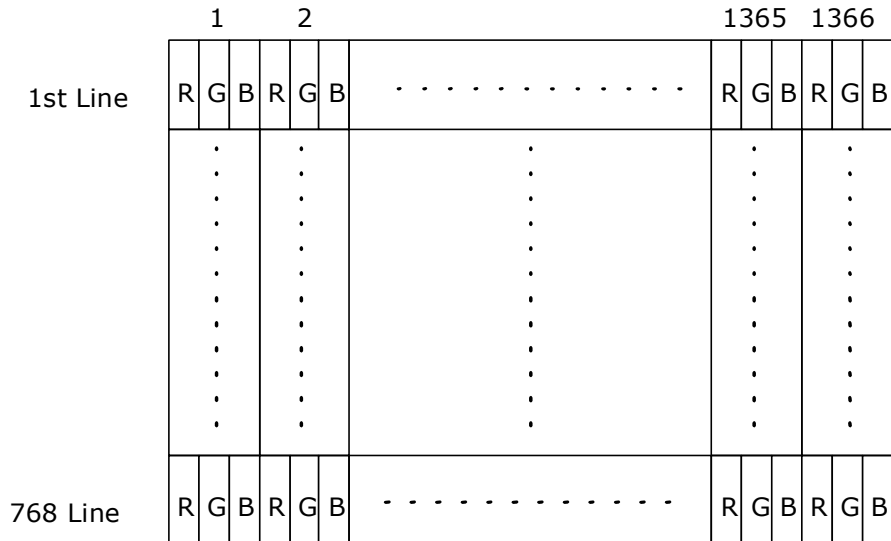

### 3.4.2 LVDS Data Format

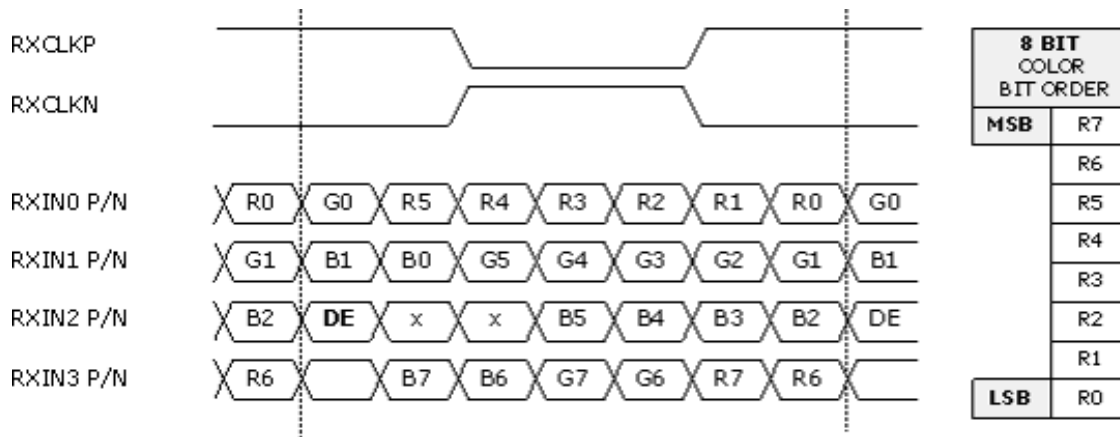

LVDS Data Mapping of NS Format

**Note 3-2:**

- a. Normally, DE, VS, HS on EVEN channel are not used.
- b. Refer to 3.4.1 LCD pixel format, the 1<sup>st</sup> data is 1, the 2<sup>nd</sup> data is 2 and the last data is 1366.
- c. 8-bits signal input.

### 3.4.3 Color versus Input Data

The following table is for color versus input data (8bit). The higher the gray level, the brighter the color.

Color	Gray Level	Color Input Data																				Remark				
		RED data (MSB:R7, LSB:R0)								GREEN data (MSB:G7, LSB:G0)								BLUE data (MSB:B7, LSB:B0)								
		R7	R6	R5	R4	R3	R2	R1	R0	G7	G6	G5	G4	G3	G2	G1	G0	B7	B6	B5	B4		B3	B2	B1	B0
Black	-	0	0	0	0	0	0	0	0	0	0	0	0	0	0	0	0	0	0	0	0	0	0	0	0	
White	-	1	1	1	1	1	1	1	1	1	1	1	1	1	1	1	1	1	1	1	1	1	1	1	1	
Gray 127	-	0	1	1	1	1	1	1	1	0	1	1	1	1	1	1	1	0	1	1	1	1	1	1	1	
Red	L0	0	0	0	0	0	0	0	0	0	0	0	0	0	0	0	0	0	0	0	0	0	0	0	0	Black
	:	:	:	:	:	:	:	:	:	:	:	:	:	:	:	:	:	:	:	:	:	:	:	:	:	
	L255	1	1	1	1	1	1	1	1	0	0	0	0	0	0	0	0	0	0	0	0	0	0	0	0	
Green	L0	0	0	0	0	0	0	0	0	0	0	0	0	0	0	0	0	0	0	0	0	0	0	0	0	Black
	:	:	:	:	:	:	:	:	:	:	:	:	:	:	:	:	:	:	:	:	:	:	:	:	:	
	L255	0	0	0	0	0	0	0	0	1	1	1	1	1	1	1	1	0	0	0	0	0	0	0	0	
Blue	L0	0	0	0	0	0	0	0	0	0	0	0	0	0	0	0	0	0	0	0	0	0	0	0	0	Black
	:	:	:	:	:	:	:	:	:	:	:	:	:	:	:	:	:	:	:	:	:	:	:	:	:	
	L255	0	0	0	0	0	0	0	0	0	0	0	0	0	0	0	0	1	1	1	1	1	1	1	1	

### 3.4.4 LVDS Specification

#### a. DC Characteristics:

Symbol	Description	Min	Typ	Max	Units	Condition
$V_{TH}$	LVDS Differential Input High Threshold	-	-	+100	[mV]	$V_{CM} = 1.2V$
$V_{TL}$	LVDS Differential Input Low Threshold	-100	-	-	[mV]	$V_{CM} = 1.2V$
$ V_{ID} $	LVDS Differential Input Voltage	100	-	600	[mV]	
$V_{CM}$	LVDS Common Mode Voltage	+1.0	+1.2	+1.5	[V]	$V_{TH}-V_{TL} = 200mV$

#### LVDS Signal Waveform:

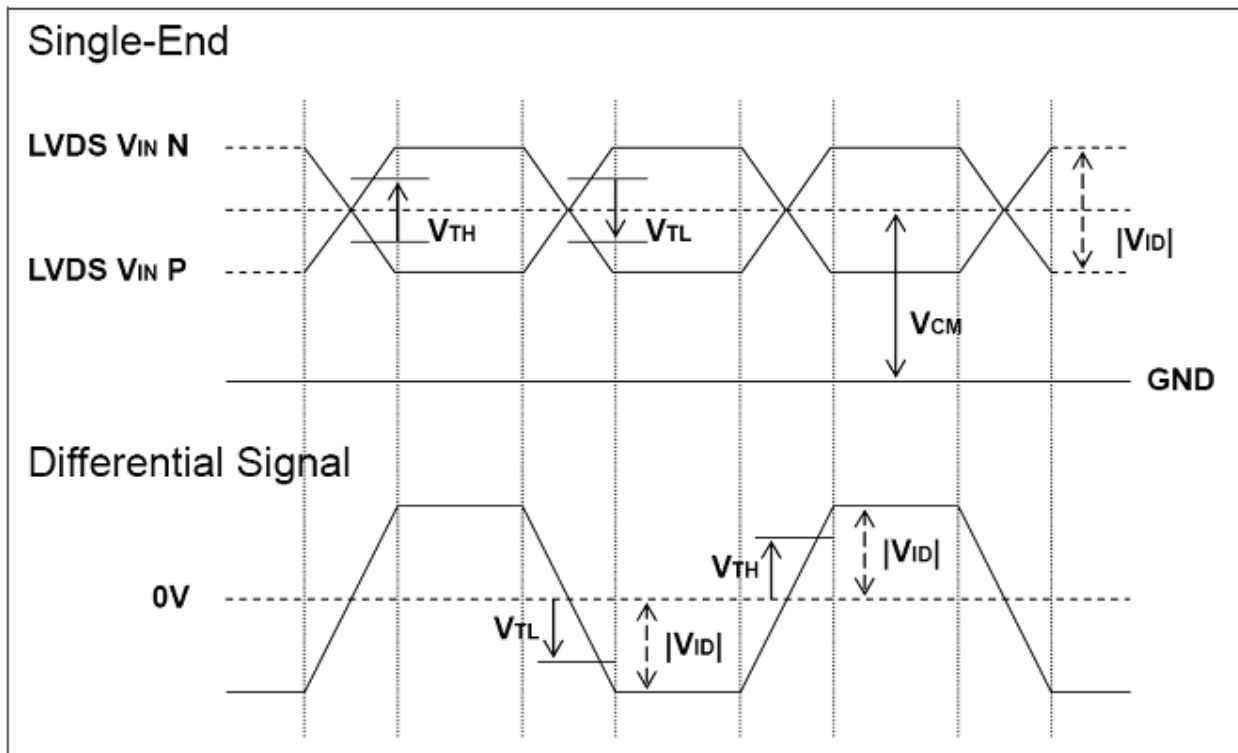



## b. AC Characteristics:

Symbol	Description	Min	Max	Unit	Remark
$F_{DEV}$	Maximum deviation of input clock frequency during Spread Spectrum	-	$\pm 3$	%	
$F_{MOD}$	Maximum modulation frequency of input clock during Spread Spectrum	-	200	KHz	

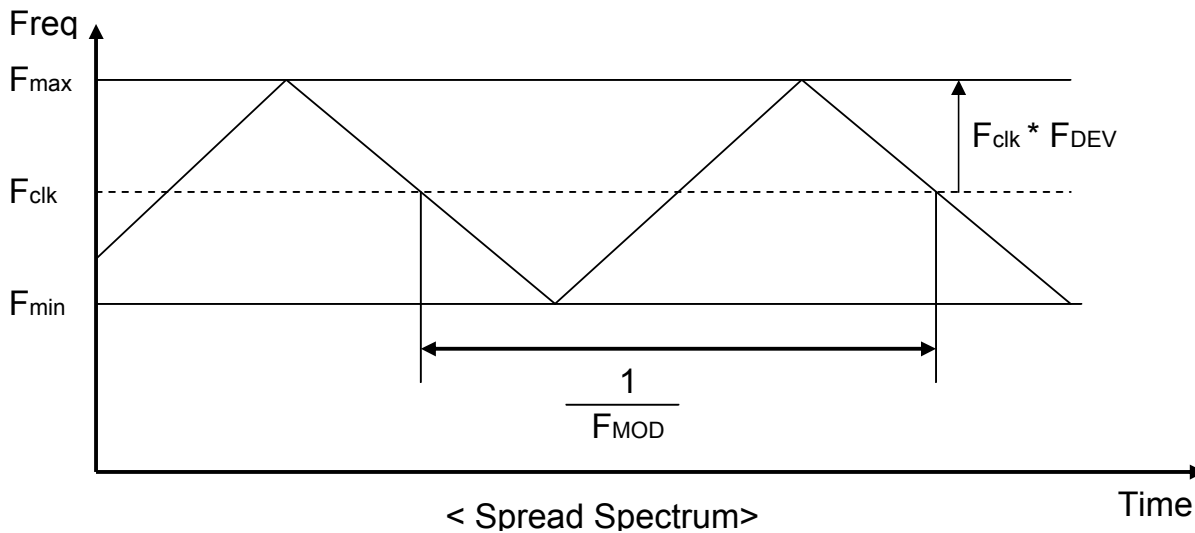

Fclk: LVDS Clock Frequency

### 3.4.5 Input Timing Specification

It only support DE mode, and the input timing are shown as the following table.

Symbol	Description		Min.	Typ.	Max.	Unit	Remark
Tv	Vertical Section	Period	793	808	1293	Th	
Tdisp (v)		Active	768	768	768	Th	
Tblk (v)		Blanking	25	40	525	Th	
Fv		Frequency	50	60	76	Hz	
Th	Horizontal Section	Period	1454	1606	2047	Tclk	
Tdisp (h)		Active	1366	1366	1366	Tclk	
Tblk (h)		Blanking	88	240	681	Tclk	
Fh		Frequency	39.7	48.5	64.6	KHz	<b>Note 3-3</b>
Tclk	LVDS Clock	Period	10.6	12.8	17.3	ns	1/Fclk
Fclk		Frequency	57.7	77.9	94.0	MHz	<b>Note 3-4</b>

**Note 3-3:** The equation is listed as following. Please don't exceed the above recommended value.

$$Fh \text{ (Min.)} = Fclk \text{ (Min.)} / Th \text{ (Min.)};$$

$$Fh \text{ (Typ.)} = Fclk \text{ (Typ.)} / Th \text{ (Typ.)};$$

$$Fh \text{ (Max.)} = Fclk \text{ (Max.)} / Th \text{ (Min.)};$$

**Note 3-4:** The equation is listed as following. Please don't exceed the above recommended value.

$$Fclk \text{ (Min.)} = Fv \text{ (Min.)} \times Th \text{ (Min.)} \times Tv \text{ (Min.)};$$

$$Fclk \text{ (Typ.)} = Fv \text{ (Typ.)} \times Th \text{ (Typ.)} \times Tv \text{ (Typ.)};$$

$$Fclk \text{ (Max.)} = Fv \text{ (Max.)} \times Th \text{ (Typ.)} \times Tv \text{ (Typ.)};$$

## 3.4.6 Input Timing Diagram

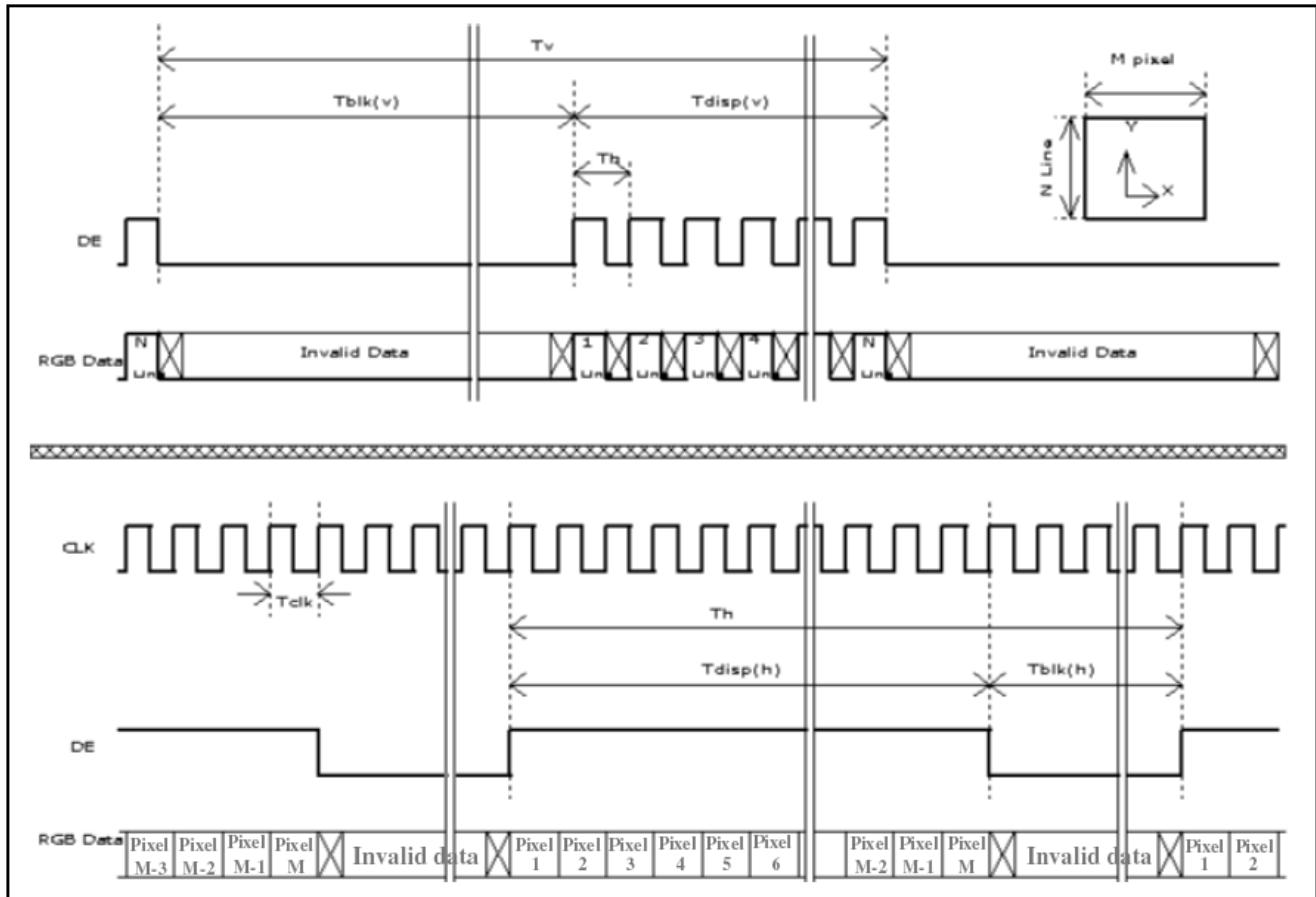

### 3.5 Power ON/OFF Sequence

VDD power, LVDS signal and backlight on/off sequence are as following. LVDS signals from any system shall be Hi-Z state when VDD is off.

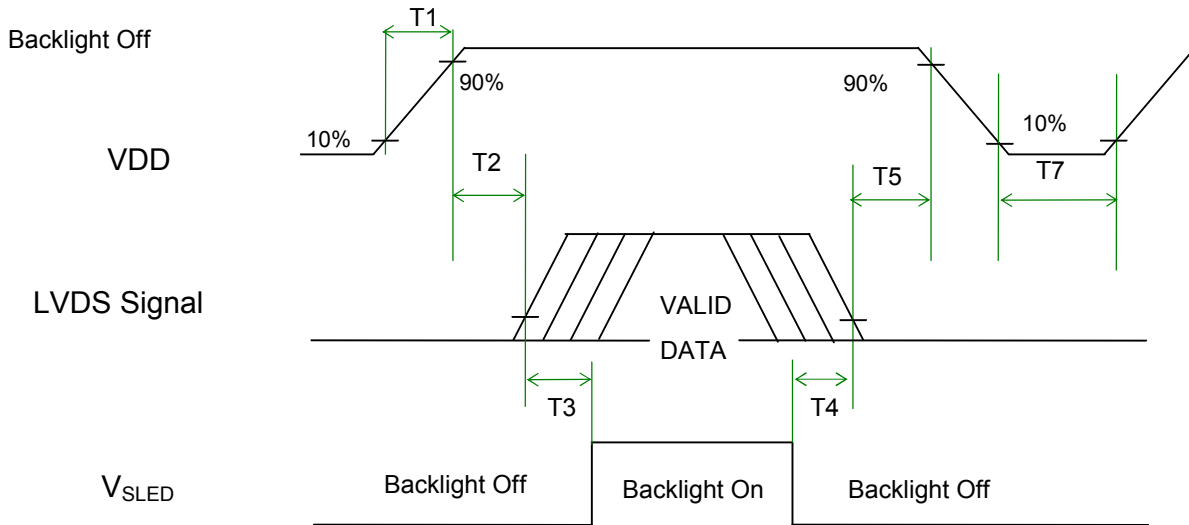

**Power Sequence Timing**

Symbol	Value			Unit	Remark
	Min.	Typ.	Max.		
T1	0.5	-	10	[ms]	
T2	0	-	50	[ms]	
T3	500	-	-	[ms]	
T4	100	-	-	[ms]	
T5	0		50	[ms]	<b>Note 3-5</b> <b>Note 3-6</b>
T7	1000	-	-	[ms]	

**Note 3-5 :** Recommend setting T5 = 0ms to avoid electronic noise when VDD is off.

**Note 3-6 :** During T5 period , please keep the level of input LVDS signals with Hi-Z state.

## 4 Backlight Unit

### 4.1 Block Diagram

The following shows the block diagram of the 18.5 inch Backlight Unit. And it includes 28 pcs LED in the LED light bar. (4 strings and 7 pcs LED of one string).

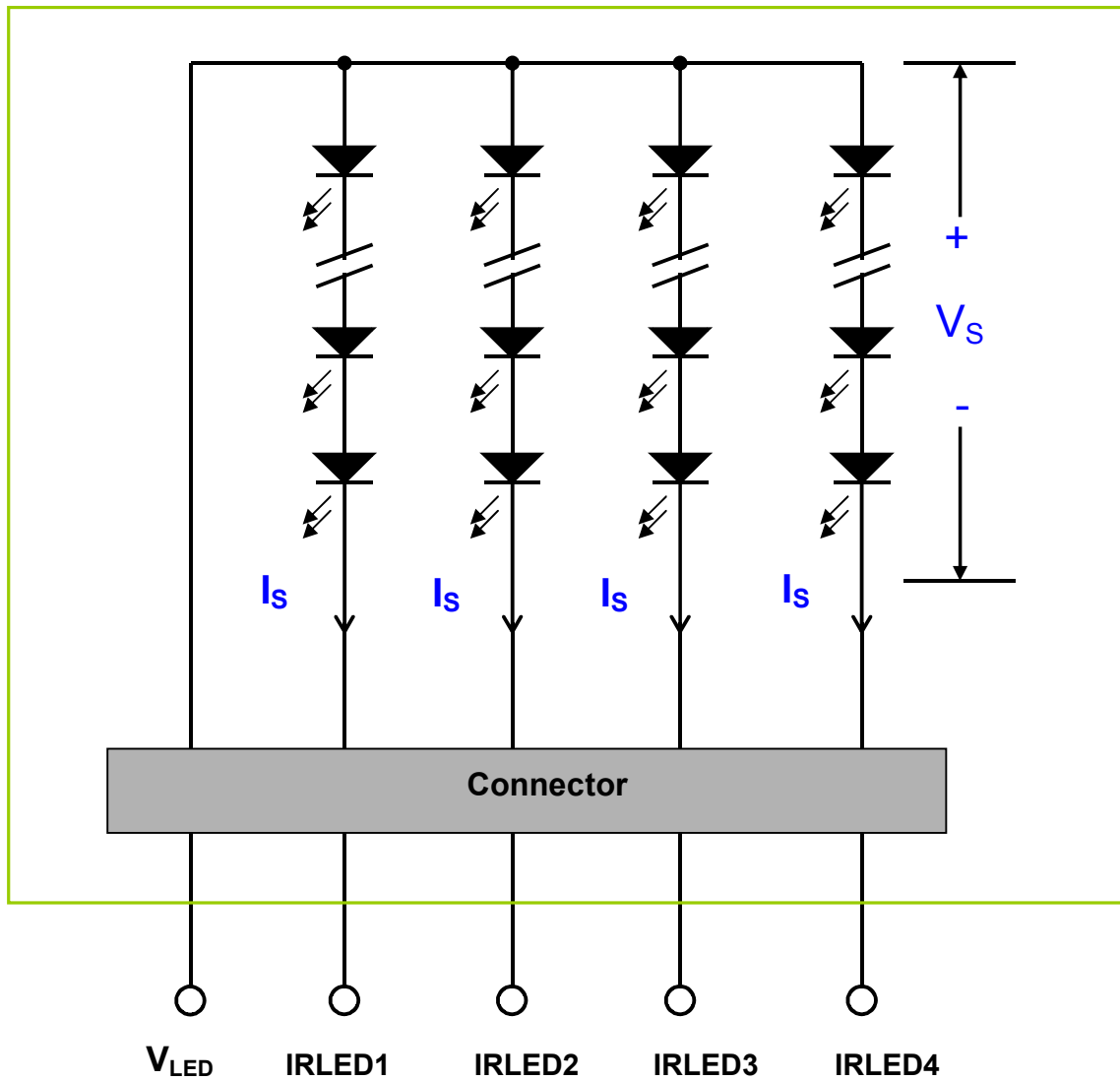

## 4.2 Interface Connection

### 4.2.1 Connector Type

Backlight Connector	Manufacturer	ENTERY
	Part Number	3707K-S06N-21R
Mating Connector	Manufacturer	ENTERY
	Part Number	3707K-S06N-21R (Wire harness)

### Backlight Connector dimension:

$H \times V \times D = 13.9 \times 3.00 \times 4.25$ , Pitch = 1.0(unit = mm)

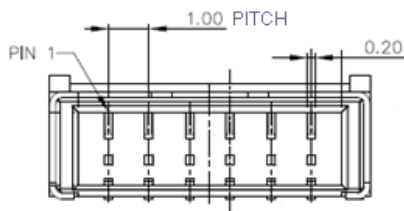
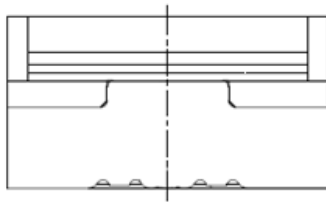

## Mating Connector dimension:

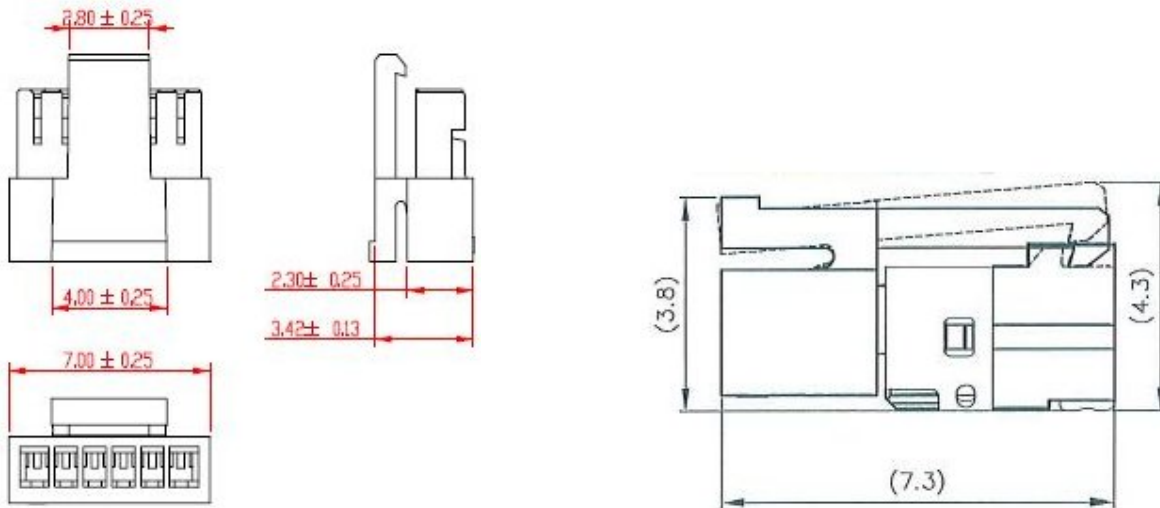



## 4.2.2 Connector Pin Assignment

Pin#	Symbol	Description	Remark
1	IRLED1	LED Current Feedback Terminal (Channel 1)	
2	IRLED2	LED Current Feedback Terminal (Channel 2)	
3	V <sub>LED</sub>	LED Power Supply Voltage Input Terminal	
4	V <sub>LED</sub>	LED Power Supply Voltage Input Terminal	
5	IRLED3	LED Current Feedback Terminal (Channel 3)	
6	IRLED4	LED Current Feedback Terminal (Channel 4)	

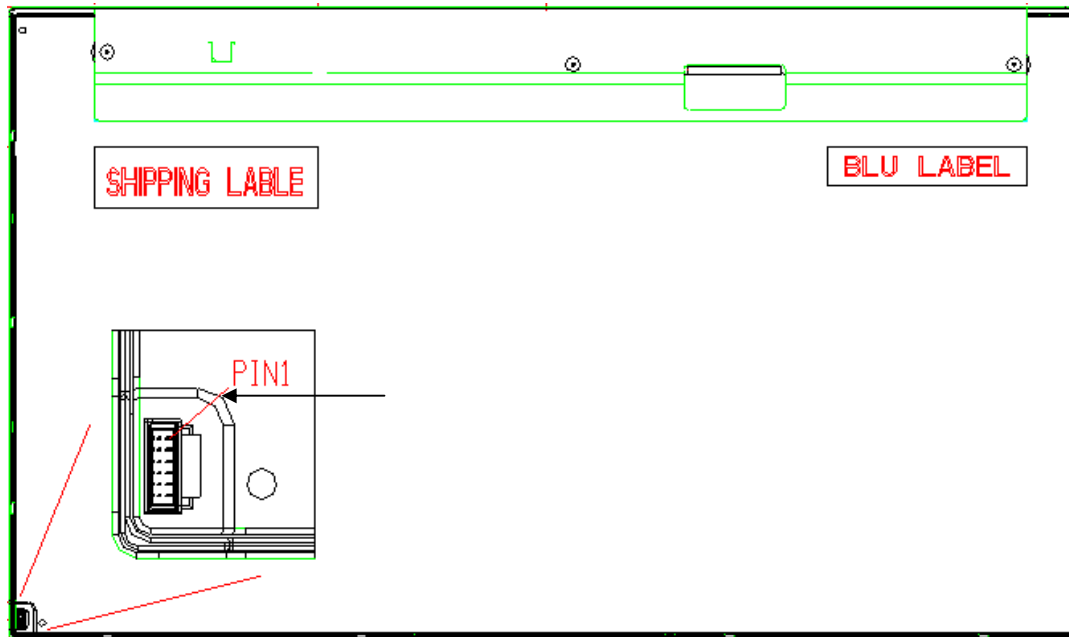

## 4.3 Electrical Characteristics

### 4.3.1 Absolute Maximum Rating

Permanent damage may occur if exceeding the following maximum rating.

(Ta=25°C)

Symbol	Description	Min	Max	Unit	Remark
Is	LED String Current	0	90	[mA]	100% duty ratio
			150	[mA]	Duty ratio ≤ 10% Pulse time=10 ms

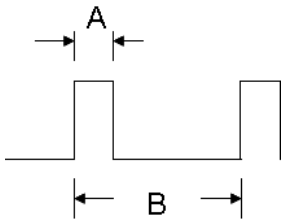

Duty ratio= (A / B) X 100% ; (A: Pulse time, B: Period)

### 4.3.2 Recommended Operating Condition

(Ta=25°C)

Symbol	Description	Min.	Typ.	Max.	Unit	Remark
Is	LED String Current	-	70	77	[mA]	100% duty ratio of LED chip
Vs	LED String Voltage	19.6	21.7	23.8	[Volt]	Is=70mA @ 100% duty ratio; <b>Note 4-1, Note 4-5</b>
ΔVs	Maximum Vs Voltage Deviation of light bar	-	-	1.4	[Volt]	Is=70mA @ 100% duty ratio; <b>Note 4-2</b>
P <sub>BLU</sub>	LED Light Bar Power Consumption	-	6.1	6.7	[Watt]	<b>Note 4-3</b>
LT <sub>LED</sub>	LED Life Time	30,000	-	-	[Hour]	<b>Note 4-4</b>
OVP	Over Voltage Protection in system board	110% Vsmax	-	-	[Volt]	<b>Note 4-5</b>

**Note 4-1:**  $V_s$  (Typ.) =  $V_F$  (Typ.) X LED No. (one string);

a.  $V_F$ : LED chip forward voltage,  $V_F$  (Min.)=2.8V,  $V_F$ (Typ.)=3.2V,  $V_F$ (Max.)=3.4V

b. The same equation to calculate  $V_s$ (Min.) &  $V_s$  (Max.) for respective  $V_F$  (Min.) &  $V_F$ (Max.);

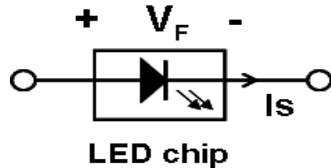

**Note 4-2:**  $\Delta V_s$  (Max.) =  $\Delta V_F$  X LED No. (one string);

a.  $\Delta V_F$ : LED chip forward voltage deviation; (0.2 V , each Bin of LED  $V_F$ )

**Note 4-3:**  $P_{BLU}$  (Typ.) =  $V_s$  (Typ.) X  $I_s$  (Typ.) X 4 ; ( 4 is total String No. of LED Light bar)

$P_{BLU}$  (Max.) =  $V_s$  (Max.) X  $I_s$  (Typ.) X 4 ;

**Note 4-4:** Definition of life time:

a. Brightness of LED becomes to 50% of its original value

b. Test condition:  $I_s$  = 70mA and 25°C (Room Temperature)

**Note 4-5:** Recommendation for LED driver power design:

Due to there are electrical property deviation in LED & monitor set system component after long time operation. AUO strongly recommend the design value of LED driver board OVP (over voltage protection) should be 10% higher than max. value of LED string voltage ( $V_s$ ) at least.

**Note 4-6:** AUO strongly recommend "Analog Dimming" method for backlight brightness control for Wavy Noise Free. Otherwise, recommend that Dimming Control Signal (PWM Signal) should be synchronized with Frame Frequency.

## 5 Reliability Test

AUO reliability test items are listed as following table. *(Bare Panel only)*

Items	Condition	Remark
Temperature Humidity Bias (THB)	Ta= 50□, 80%RH, 300hours	
High Temperature Operation (HTO)	Ta= 50□, 50%RH, 300hours	
Low Temperature Operation	Ta= 0□, 300hours	
High Temperature Storage (HTS)	Ta= 60□, 300hours	
Low Temperature Storage (LTS)	Ta= -20□, 300hours	
Vibration Test (Non-operation)	Acceleration: 1.5 Grms Wave: Random Frequency: 10 - 200 Hz Sweep: 30 Minutes each Axis (X, Y, Z)	
Shock Test (Non-operation)	Acceleration: 50 G Wave: Half-sine Active Time: 20 ms Direction: ±X, ±Y, ±Z (one time for each Axis)	
Thermal Shock Test (TST)	-20□/30min, 60□/30min, 100 cycles	<b>Note 5-1</b>
On/Off Test	On/10sec, Off/10sec, 30,000 cycles	
ESD (Electro Static Discharge)	Contact Discharge: ± 15KV, 150pF(330Ω ) 1sec, 8 points, 25 times/ point.	<b>Note 5-2</b>
	Air Discharge: ± 15KV, 150pF(330Ω ) 1sec 8 points, 25 times/ point.	
Altitude Test	Operation:18,000 ft Non-Operation:40,000 ft	

**Note 5-1:** a. A cycle of rapid temperature change consists of varying the temperature from -20□ to 60□, and back again. Power is not applied during the test.  
b. After finish temperature cycling, the unit is placed in normal room ambient for at least 4 hours before power on.

**Note 5-2:** EN61000-4-2, ESD class B: Certain performance degradation allowed  
No data lost  
Self-recoverable  
No hardware failures.

## 6 Shipping Label

The label is on the panel as shown below:

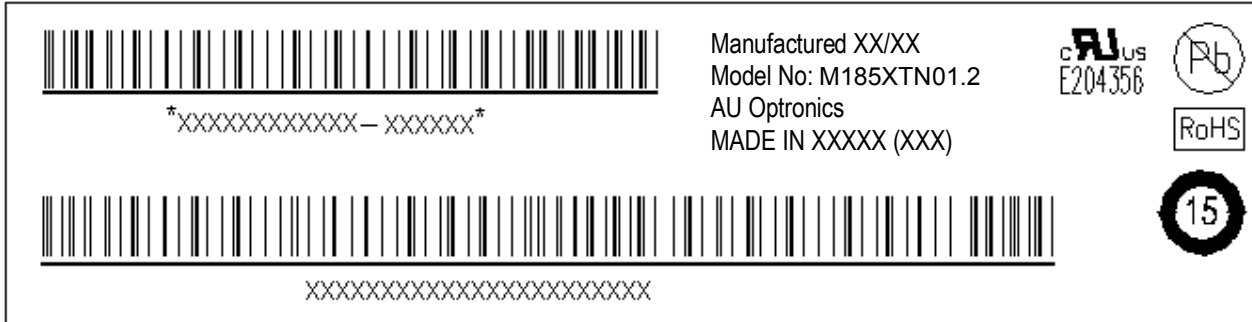

**Note 6-1:** For Pb Free products, AUO will add  for identification.

**Note 6-2:** For RoHS compatible products, AUO will add  for identification.

**Note 6-3:** For China RoHS compatible products, AUO will add  for identification.

**Note 6-4:** The Green Mark will be presented only when the green documents have been ready by AUO Internal Green Team.

# 7 Mechanical Characteristics

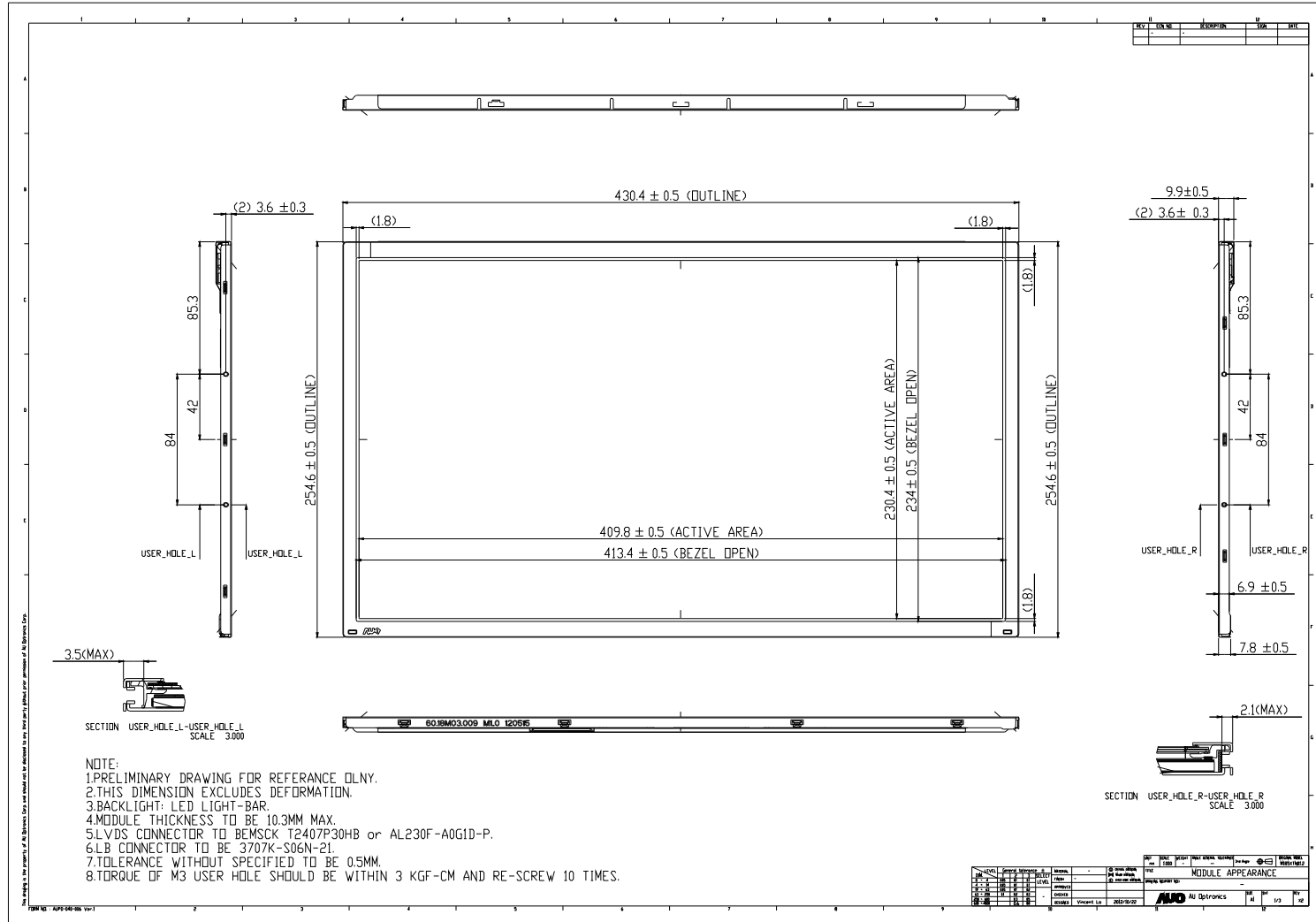



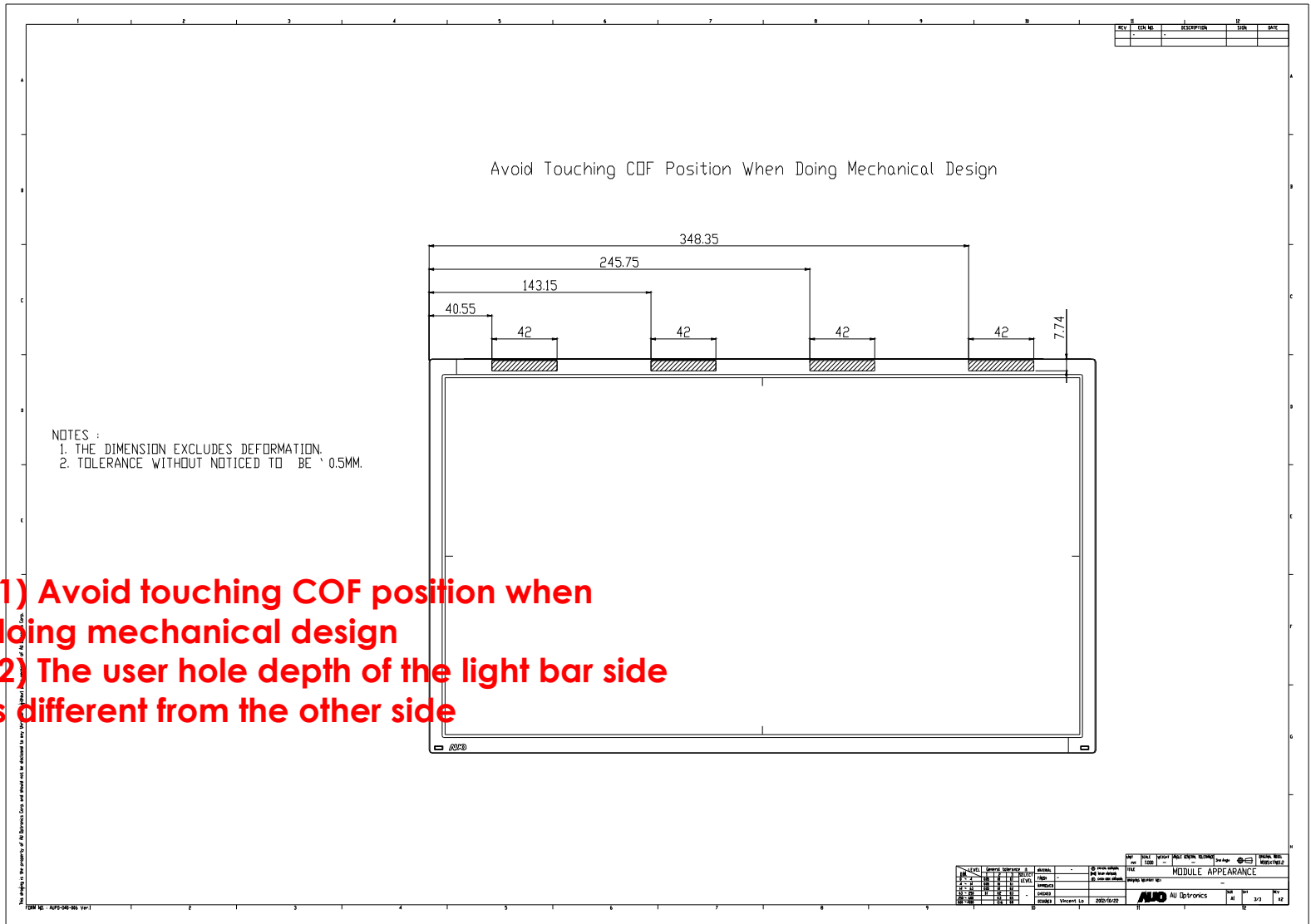

**(1) Avoid touching COF position when doing mechanical design**

**(2) The user hole depth of the light bar side is different from the other side**



## 8 Packing Specification

### 8.1 Packing Flow

M185 15pcs Carton OD:48.1\*36.2\*33.0cm

AUO Part NO:

Carton PN 81.18M03.003 / Cushion PN 84.18M03.011

面板貼附保護膜裝入靜電袋，均P板朝上依序放入EPE緩衝中(2片一格)，滿箱裝 15pcs



左右邊以美紋膠帶固定保護膜



1<sup>st</sup> Panel可視區朝上&T-CON朝向袋口，放入靜電袋



2<sup>nd</sup> Panel可視區朝下 & T-CON朝向袋口，放入靜電袋，使2pcs Panel的可視區面對面

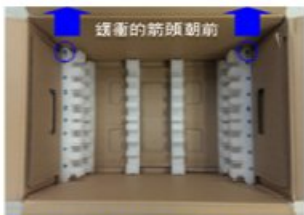

Carton + Bottom cushion



首先將Panel\*1pcs放入中間凹槽內



依序以F2F方式，從中間往兩側將Panel放入凹槽內



依序將Panel放入凹槽內直至滿箱



左右邊上面放置上蓋\*2



封箱完成

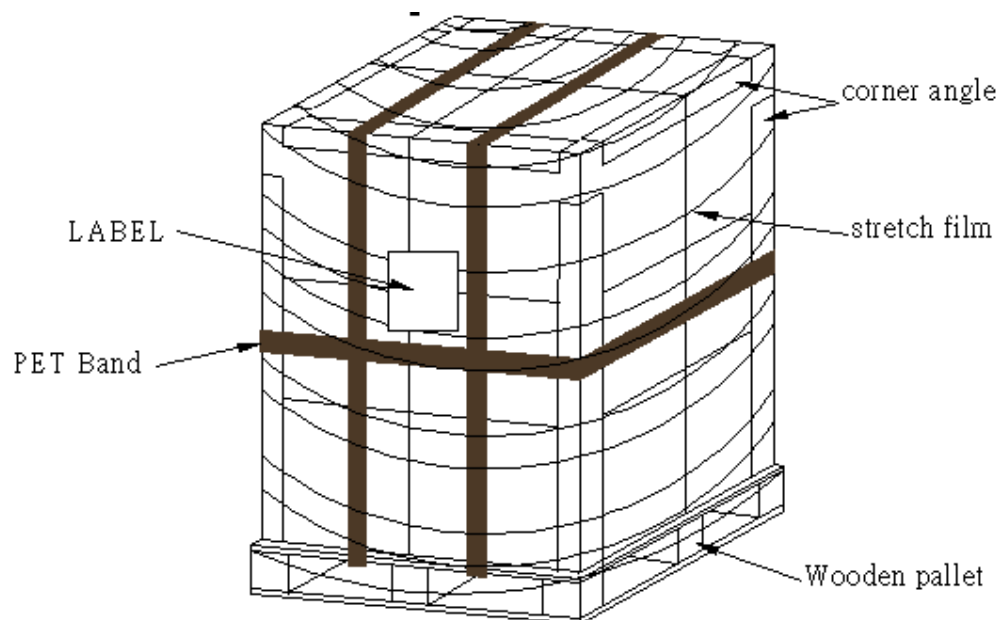

單層 pallet 打棧示意圖

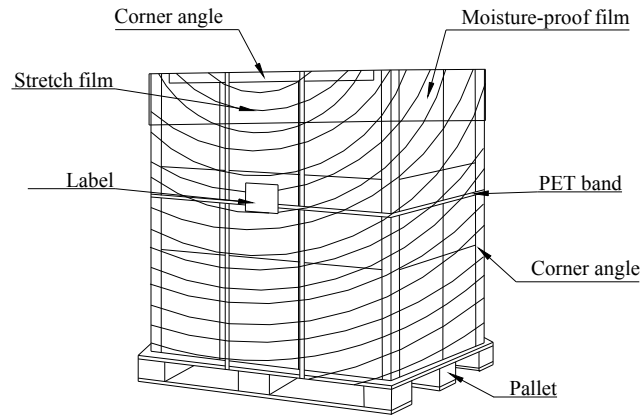

## 8.2 Pallet and shipment information

Item	Specification			Remark
	Q'ty	Dimension	Weight(kg)	
Panel	1	430.37(H)mm x 254.6(V)mm x 9.9(D)mm	1.330	
Cushion	1	-	1.125	
Box	1	481(L)mm x 362(W)mm x 330(H)mm	1.58	without Panel & cushion
Packing Box	15 pcs/Box	481(L)mm x 362(W)mm x 330(H)mm	21.54	with panel & cushion
Pallet	1	1150(L)mm x 980(W)mm x 132(H)mm	15	
Pallet after Packing	18 boxes/pallet	1150(L)mm x 980(W)mm x 1122(H)mm	402.72	

