

TFT-DISPLAY DATASHEET

AUO
Model: G213QAN01.0

BRIEF SPEC.:

Main Feature

Landscape Type

Normally Black Display Mode

Active Screen Area	433.15 x 324.86 (mm)
Diagonal Format	21.3" 4:3
Resolution	2048 X 1536
Colors	1.073B (True 10Bit)
Backlight	LED
Brightness	800 cd/m ²
LED Life Time	50K (h)
Interface	LVDS
Viewing Angle	89/89 L/R 89/89
Touchscreen	No
Power Supply	12 V (Typ.)
Module Outline	457.0 x 350.0 x 22.3 (mm)
Operation Temperature	0... +60 °C
Storage Temperature	-20... +60 °C
Surface Treatment	Anti-Glare



Product Specification

G213QAN01.0

AU OPTRONICS CORPORATION

Preliminary Specification

Final Specification

Module	21.3" QXGA Color TFT-LCD
Model Name	G213QAN01.0

Customer	Date
_____	_____
Approved by	
_____	_____
<p>Note: This Specification is subject to change without notice.</p>	

Checked & Approved by	Date
<u><i>Crystal Hsieh</i></u>	<u>2/2, 2016</u>
Prepared by	
<u><i>Sandy Su</i></u>	<u>2/2, 2016</u>
<p>GD Business Unit / AU Optronics corporation</p>	



Record of Revision

Version &	Page	Old Description	New Description
0.1 2014/4/29	All	Frist Edition for Customers	
0.2 2016/2/2	5	2.1 Display Characteristics White Luminance: 800 (center, Typ) @ 125 mA Contrast Ratio: 1200: 1 (Typ) Power Consumption LED: 60 (W) Weight: 2700 (Typ) Physical Size : 457 (H) x 350 (V) x 19.81 (D) (Typ)	White Luminance: → 800 (center, Typ) @ 85 mA Contrast Ratio: → 1400: 1 (Typ) Power Consumption LED: → 43 (W) Weight: → 3200 (Typ) Physical Size : → 457 (H) x 350 (V) x 22.3 (D) (Typ)
	6	Color / Chromaticity Coordinates Red x: 0.640 Red y: 0.330 Contrast Ratio: 1200 (Typ)	Red x; Red y Revised → 0.656 → 0.326 Contrast Ratio: → 1400: 1 (Typ)
	9	I/F PCB Interface: FX15S-41S-0.5SH (HIROSE)	→ FX15SC-41S-0.5SH (HIROSE)
	13	5.2 Backlight Unit IVDD :2.5(Typ.);2.7(Max.) PVDD :60(Typ.);64.8(Max.) IF:125(Typ.) for VF, PLED, LED lifetime PLED 55(Typ.);61.8(Max.)	IVDD:→1.9(Typ.);2.1(Max.) PVDD :→45.6(Typ.);50.4(Max.) IF:→85(Typ.) for VF, PLED, LED lifetime PLED →43(Typ.);48(Max.)
	23	7.1.1 Connector Type Part Number: FX15S-41S-0.5SH (HIROSE)	→ FX15SC-41S-0.5SH (HIROSE)
	25	No Note	Add Note
	29	Mechanical Characteristic_Front View	Revised
30	Mechanical Characteristic_Back View	Revised	



Contents

1. Handling Precautions	4
2. General Description	5
2.1 Display Characteristics	5
2.2 Optical Characteristics.....	6
3. Functional Block Diagram	9
4. Absolute Maximum Ratings	10
4.1 Absolute Ratings of TFT LCD Module	10
4.2 Absolute Ratings of Backlight Unit.....	10
4.3 Absolute Ratings of Environment.....	10
5. Electrical characteristics	11
5.1 TFT LCD Module	11
5.2 Backlight Unit.....	13
6. Signal Characteristic	14
6.1 Pixel Format Image.....	14
6.2 The Input Data Format.....	15
6.4 Interface Timing.....	20
6.5 Power ON/OFF Sequence	22
7. Connector & Pin Assignment	23
7.1 TFT LCD Module	23
7.2 Backlight Unit.....	25
8. Reliability Test	26
9. Shipping Label and Packaging	27
9.1 Shipping Label.....	27
9.2 Packaging	27
10. Mechanical Characteristic	29

1. Handling Precautions

- 1) Since front polarizer is easily damaged, pay attention not to scratch it.
- 2) Be sure to turn off power supply when inserting or disconnecting from input connector.
- 3) Wipe off water drop immediately. Long contact with water may cause discoloration or spots.
- 4) When the panel surface is soiled, wipe it with absorbent cotton or other soft cloth.
- 5) Since the panel is made of glass, it may break or crack if dropped or bumped on hard surface.
- 6) Since CMOS LSI is used in this module, take care of static electricity and insure human earth when handling.
- 7) Do not open or modify the Module Assembly.
- 8) Do not press the reflector sheet at the back of the module to any directions.
- 9) In case if a Module has to be put back into the packing container slot after once it was taken out from the container, do not press the center of LED light bar edge. Instead, press at the far ends of LED light bar edge softly. Otherwise the TFT Module may be damaged.
- 10) At the insertion or removal of the Signal Interface Connector, be sure not to rotate nor tilt the Interface Connector of the TFT Module.
- 11) After installation of the TFT Module into an enclosure, do not twist nor bend the TFT Module even momentary. At designing the enclosure, it should be taken into consideration that no bending or twisting forces are applied to the TFT Module from outside. Otherwise the TFT Module may be damaged.
- 12) Small amount of materials having no flammability grade is used in the LCD module. The LCD module should be supplied by power complied with requirements of Limited Power Source (IEC60950 or UL1950), or be applied exemption.
- 13) Don't display the fixed pattern for a long time to avoid image sticking. If the fixed pattern is displayed on the screen, use a screen saver.
- 14) Avoid stressing front bezel position when doing mechanical design. This product must be installed by using mounting holes without undue such as bending or twist. Also do not add undue stress to any portion, ex: near bezel area. Bending or twist may cause this display mura or light leakage.
Recommended installing method: The plane "A" is defined from one mounting hole to other mounting holes. Plane A must be the same plane within ± 0.3 mm.

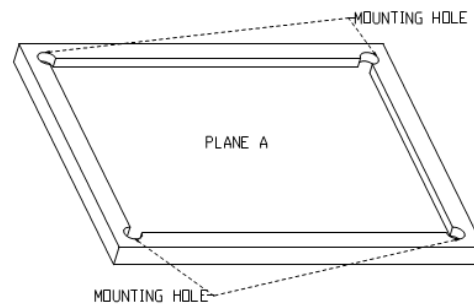

- 15) Do not operate or store in high temperature, high humidity, dewdrop atmosphere or corrosive gases. Keep the product in packing box with antistatic package in room temperature to avoid dusts when store the product.



2. General Description

G213QAN01.0 is a Color Active Matrix Liquid Crystal Display composed of a TFT-LCD panel, a driver circuit, and a backlight system. The screen format is intended to support the QXGA (2048(H) x 1536(V)) screen and 1.073B colors (10 bits). All input signals are 4port-LVDS interface compatible.

2.1 Display Characteristics

The following items are characteristics summary on the table under 25 °C condition:

Items	Unit	Specifications
Screen Diagonal	[mm]	541.0 (21.3")
Active Area	[mm]	433.152 (H) x 324.864 (V)
Pixels H x V		2048(*3) x 1536
Pixel Pitch	[mm]	0.2115 (per one triad) x 0.2115
Pixel Arrangement		R.G.B. Vertical Stripe
Display Mode		Normally Black
White Luminance	[cd/m2]	800 (center,Typ.) @ 85 mA
Contrast Ratio		1400: 1 (Typ)
Optical ResponseTime	[msec]	25 (Typ, on/off)
Nominal Input Voltage VCC	[Volt]	+12.0 V
Power Consumption	[Watt]	LED: 43 (W) + LVDS: 8.4 (W) (typ)
Weight	[Grams]	3200 (TYP)
Physical Size (H x V x D)	[mm]	457 (H) x 350 (V) x 22.3 (D) (Typ)
Electrical Interface		4port-LVDS
Surface Treatment		Anti-Glare treatment
Support Color		1.073B colors (True 10 Bit)
Temperature Range Operating Storage (Non-Operating)	[°C] [°C]	0 to +60 -20 to +60
RoHS Compliance		RoHS Compliance



2.2 Optical Characteristics

The optical characteristics are measured under stable conditions at 25°C (Room Temperature) and without any stress on panel.

Item	Unit	Conditions	Min.	Typ.	Max.	Note
Viewing Angle	[degree]	Horizontal (Right)	75	89	-	1
		CR = 10 (Left)	75	89		
		Vertical (Up)	75	89	-	
		CR = 10 (Down)	75	89		
Luminance Uniformity	[%]	9 Points	80	-	-	2, 3
Optical Response Time	[msec]	Rising	-	13	18	4, 5
		Falling	-	12	17	
		Rising + Falling	--	25	35	
Color / Chromaticity Coordinates (CIE)		Red x	TBD	0.656	TBD	4
		Red y	TBD	0.326	TBD	
		Green x	TBD	0.300	TBD	
		Green y	TBD	0.600	TBD	
		Blue x	TBD	0.150	TBD	
		Blue y	TBD	0.060	TBD	
		White x	TBD	0.299	TBD	
White y	TBD	0.315	TBD			
White Luminance (At LED= 85mA)	[cd/m ²]		TBD	800	-	4
Contrast Ratio			TBD	1400	-	4

Note 1: Definition of viewing angle, measured by ELDIM (EZContrast 88)

Viewing angle is the measurement of contrast ratio ≥ 10 , at the screen center, over a 180° horizontal and 180° vertical range (off-normal viewing angles). The 180° viewing angle range is broken down as follows; 90° (θ) horizontal left and right and 90° (Φ) vertical, high (up) and low (down). The measurement direction is typically perpendicular to the display surface with the screen rotated about its center to develop the desired measurement viewing angle.

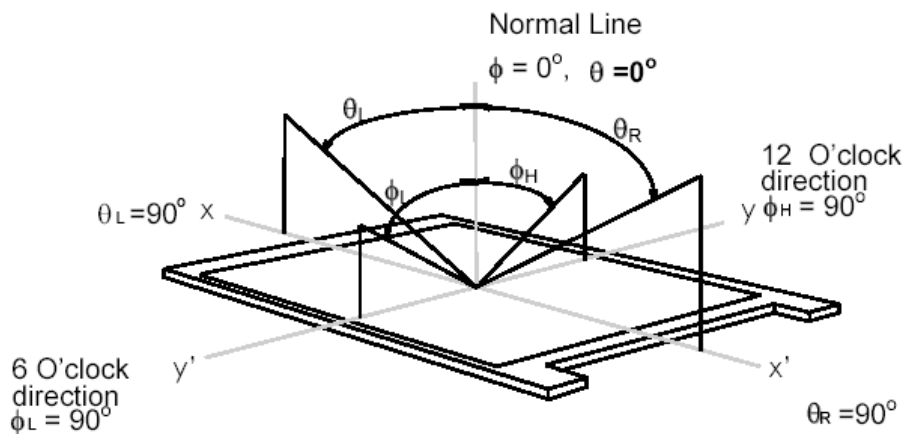

Note 2: 9 points position

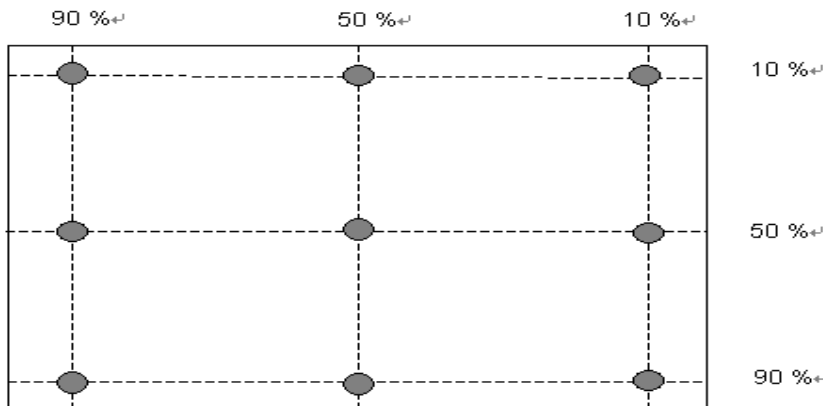

Note 3: The luminance uniformity of 9 points is defined by dividing the maximum luminance values by the minimum test point luminance. And measured by TOPCON SR-3

$$\delta_{w9} = \frac{\text{Minimum Luminance of 9 points}}{\text{Maximum Luminance of 9 points}}$$

Note 4: Measurement method

The LCD module should be stabilized at given temperature for 30 minutes to avoid abrupt temperature change during measuring. In order to stabilize the luminance, the measurement should be executed after lighting Backlight for 30 minutes in a stable, windless and dark room.

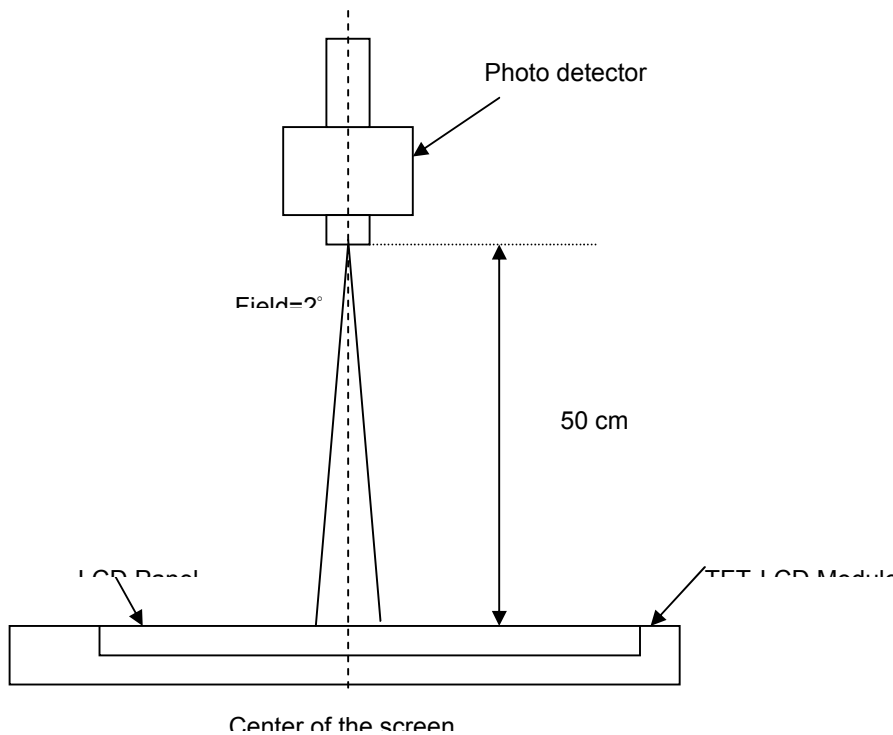

Note 5: Definition of response time, measured by WESTAR TRD-100A

The output signals of photo detector are measured when the input signals are changed from “Full Black” to “Full White” (rising time), and from “Full White” to “Full Black” (falling time), respectively. The response time is interval between the 10% and 90% of amplitudes. Please refer to the figure as below.

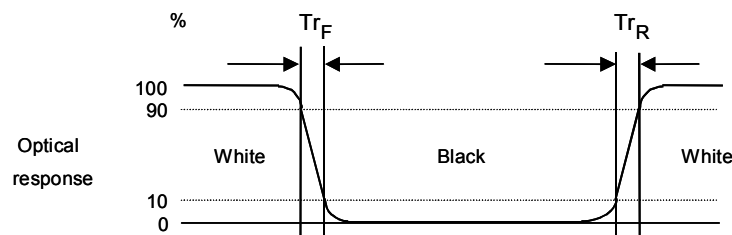

3. Functional Block Diagram

The following diagram shows the functional block of the 21.3 inches Color TFT-LCD Module:

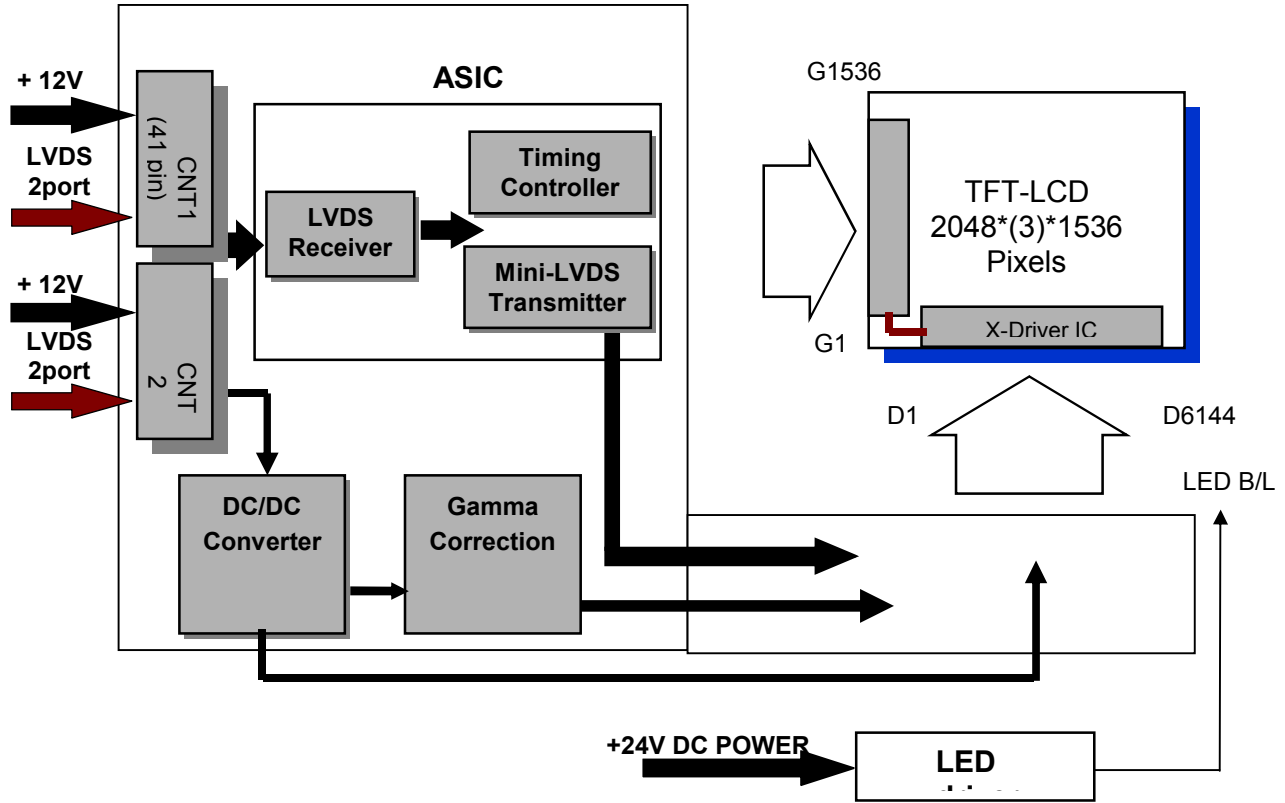

I/F PCB Interface:

FX15SC-41S-0.5SH (HIROSE)

Mating Type:

FX15S-41P-C (HIROSE)

4. Absolute Maximum Ratings

Absolute maximum ratings of the module are as following:

4.1 Absolute Ratings of TFT LCD Module

Item	Symbol	Min.	Max.	Unit	Conditions
Logic/LCD Drive Voltage	VCC	-0.3	+23	[Volt]	Note 1, 2

4.2 Absolute Ratings of Backlight Unit

Item	Symbol	Min.	Max.	Unit	Conditions
LED Power Current	Iled	-	1.7	[A] rms	Note 1, 2

4.3 Absolute Ratings of Environment

Item	Symbol	Min.	Max.	Unit	Conditions
Operating Temperature	TOP	0	+60	[°C]	Note 3 & 4
Operation Humidity	HOP	5	90	[%RH]	
Storage Temperature	TST	-20	+60	[°C]	
Storage Humidity	HST	5	90	[%RH]	

Note 1: With in Ta= 25°C

Note 2: Permanent damage to the device may occur if exceed maximum values

Note 3: For quality performance, please refer to AUO IIS (Incoming Inspection Standard).

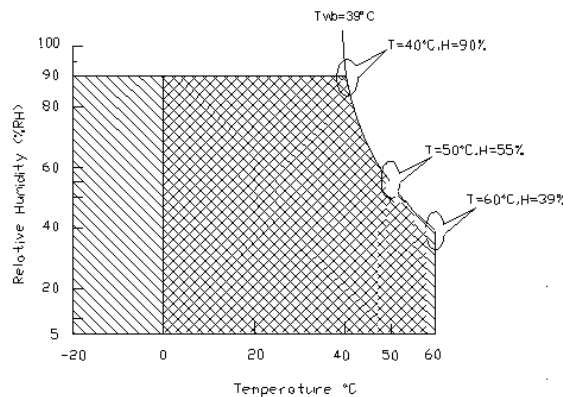

Operating Range



Storage Range

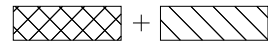

Note 4: Operation Temperature + 60°C is defined as panel surface temperature.

5. Electrical characteristics

5.1 TFT LCD Module

5.1.1 Power Specification

Input power specifications are as follows:

Symble	Parameter	Min.	Typ.	Max.	Unit	Condition
VCC	Logic/LCD Drive Voltage	11.5	12	12.5	[Volt]	± 10%
ICC	Input Current	-	0.7	0.9	[A]	Vin=12V, White Pattern, at 60Hz
IRush	Inrush Current	-	2.7	3.4	[A]	Note 2
PCC	VCC Power	-	8.4	10.8	[Watt]	Vin=12V , White Pattern, at 60Hz
VCCrp	Allowable Logic/LCD Drive Ripple Voltage	-	-	300	[mV] p-p	With panel loading

Note 2: Measurement conditions:

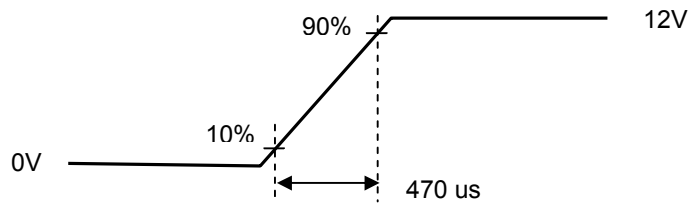
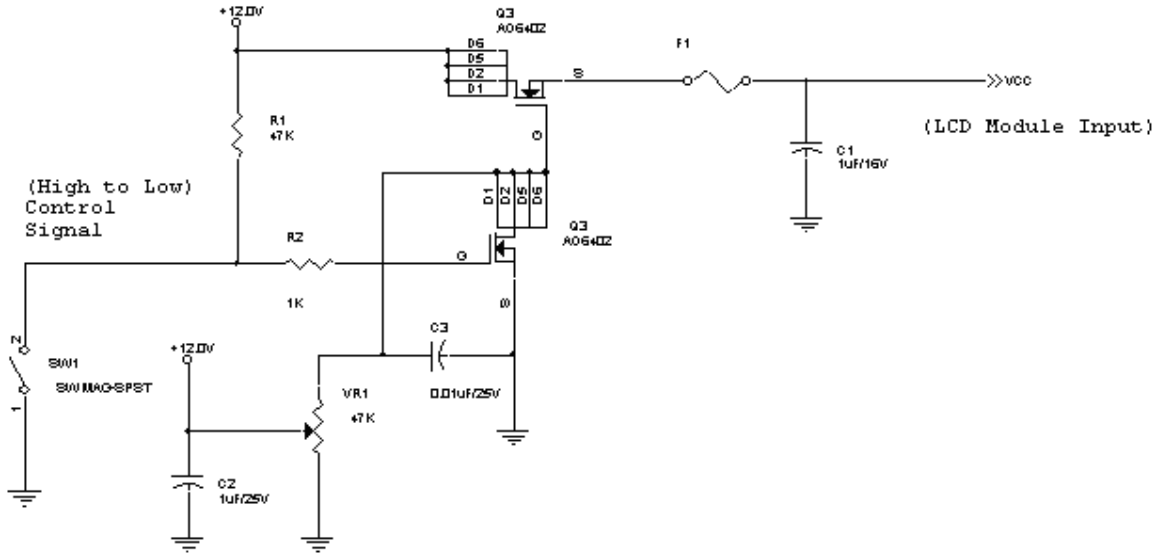

VCC rising time

5.2 Backlight Unit

Following characteristics are measured under a stable condition at 25 °C (Room Temperature):

Symbol	Parameter	Min.	Typ.	Max.	Unit	Remark
VDD	Input Voltage	23.5	24	24.5	[Volt]	
I_{VDD}	Input Current		1.9	2.1	[A]	100% PWM Duty
P_{VDD}	Power Consumption		45.6	50.4	[Watt]	100% PWM Duty
I_{rush LED}	Inrush Current	-	-	6	[A]	at rising time=470us
Analog Control	Input Voltage	0	-	3	V	
F_{PWM}	Dimming Frequency		0.2	20	[kHz]	
	Swing Voltage	2.5	3.3	5	V	
	Dimming Duty Cycle	10	-	100	%	
I_F	LED Forward Current		85		mA	Ta = 25°C
V_F	LED Forward Voltage	-	3.2-	3.6	Volt	I _F =85 mA, Ta = 25°C
P_{LED}	LED Power Consumption	-	43	48	Watt	I _F =85 mA, Ta = 25°C Two Light Bar (Total LED Power)
LED Lifetime		50,000			Hrs	I _F =85 mA, Ta= 25°C

Note 1: Ta means ambient temperature of TFT-LCD module.

Note 2: VDD, I_{VDD}, P_{VDD}, I_{rush LED} are defined for LED B/L.(100% duty of PWM dimming)

Note 3: I_F, V_F, P_{LED} are defined for LED Light Bar.

Note 4: If G213QAN01.0 module is driven by high current or at high ambient temperature & humidity condition. The operating life will be reduced.

Note 5: LED life means brightness goes down to 50% initial brightness of LED Part. The minimum life time of LED unit is on the condition of I_F = 85mA and 25±2□(Room temperature).

Note 6: Two kind types for adjusting brightness: PWM and Analog.

6. Signal Characteristic

6.1 Pixel Format Image

Following figure shows the relationship of the input signals and LCD pixel format.

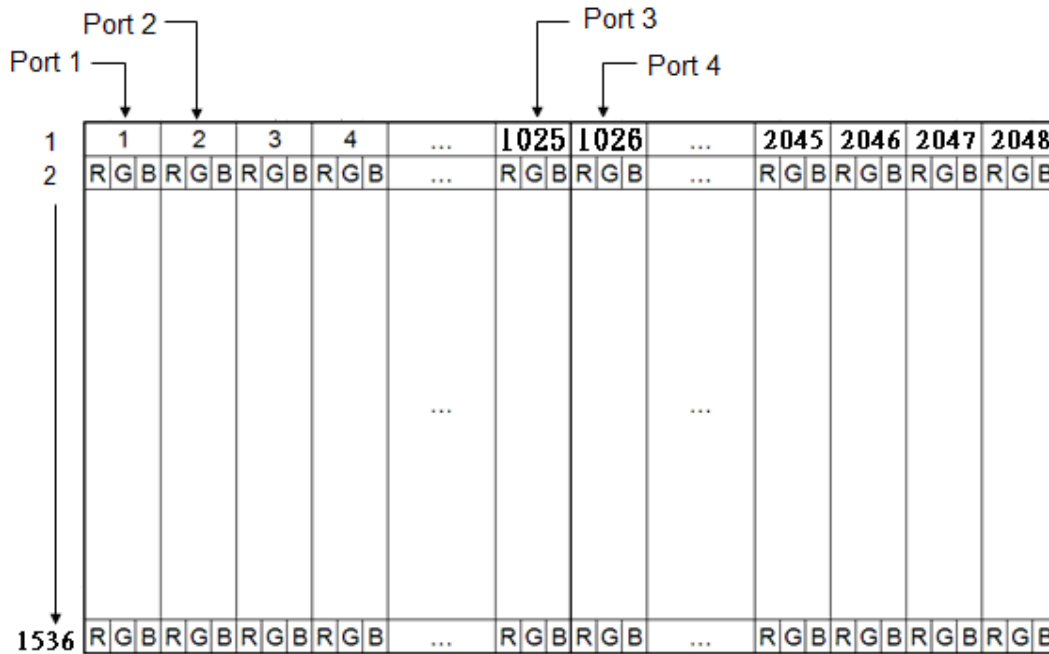

Note 1: The module use 4port-LVDS interface.

Port 1 LVDS : 1, 3.....→1023pixel

Port 2 LVDS : 2, 4.....→1024pixel

Port 3 LVDS : 1025, 1027.....→2047 pixel

Port 4 LVDS : 1026, 1028.....→2048 pixel

6.2 The Input Data Format

Data Mapping of JEIDA Format



LVDS Data Mapping of JEIDA Format for Quad Channel

Note1: Normally DE mode only

Note2: Please follow VESA.

Note3: 10-bit in



6.3 Signal Description

The module using 41/41 pin 4port-LVDS interface. LVDS is a differential signal technology for LCD interface and high speed data transfer device.

Module Connector - CNT1

PIN #	Signal Name	Description	Function
1	VCC	Power +12V	Power
2	VCC	Power +12V	
3	VCC	Power +12V	
4	VCC	Power +12V	
5	VCC	Power +12V	
6	GND	Power Ground	
7	GND	Power Ground	
8	GND	Power Ground	
9	GND	Power Ground	
10	RXIN10_N	FIRST_ Negative LVDS differential data input	LVDS port 1
11	RXIN10_P	FIRST_ Positive LVDS differential data input	
12	RXIN11_N	FIRST_ Negative LVDS differential data input	
13	RXIN11_P	FIRST_ Positive LVDS differential data input	
14	GND	Power Ground	
15	RXIN12_N	FIRST_ Negative LVDS differential data input	
16	RXIN12_P	FIRST_ Positive LVDS differential data input	
17	R1_CLKN	FIRST_ Negative LVDS differential clock input	
18	R1_CLKP	FIRST_ Positive LVDS differential clock input	
19	GND	Power Ground	
20	RXIN13_N	FIRST_ Negative LVDS differential data input	
21	RXIN13_P	FIRST_ Positive LVDS differential data input	
22	RXIN14_N	FIRST_ Negative LVDS differential data input	
23	RXIN14_P	FIRST_ Positive LVDS differential data input	
24	GND	Power Ground	
25	RXIN20_N	SECOND_ Negative LVDS differential data input	LVDS port 2
26	RXIN20_P	SECOND_ Positive LVDS differential data input	



27	RXIN21_N	SECOND_ Negative LVDS differential data input	
28	RXIN21_P	SECOND_ Positive LVDS differential data input	
29	GND	Power Ground	
30	RXIN22_N	SECOND_ Negative LVDS differential data input	
31	RXIN22_P	SECOND_ Positive LVDS differential data input	
32	R2_CLKN	SECOND_ Negative LVDS differential clock input	
33	R2_CLKP	SECOND_ Positive LVDS differential clock input	
34	GND	Power Ground	
35	RXIN23_N	SECOND_ Negative LVDS differential data input	
36	RXIN23_P	SECOND_ Positive LVDS differential data input	
37	RXIN24_N	SECOND_ Negative LVDS differential data input	
38	RXIN24_P	SECOND_ Positive LVDS differential data input	
39	GND	Power Ground	
40	NC	No connection (for AUO test only. Do not connect)	
41	NC	No connection (for AUO test only. Do not connect)	

Module Connector – CNT2

PIN #	Signal Name	Description	Function
1	VCC	Power +12V	Power
2	VCC	Power +12V	
3	VCC	Power +12V	
4	VCC	Power +12V	
5	VCC	Power +12V	
6	GND	Power Ground	
7	GND	Power Ground	
8	GND	Power Ground	
9	GND	Power Ground	
10	RXIN30_N	THIRD_ Negative LVDS differential data input	LVDS port 3
11	RXIN30_P	THIRD_ Positive LVDS differential data input	
12	RXIN31_N	THIRD_ Negative LVDS differential data input	



13	RXIN31_P	THIRD_ Positive LVDS differential data input	LVDS port 4
14	GND	Power Ground	
15	RXIN32_N	THIRD_ Negative LVDS differential data input	
16	RXIN32_P	THIRD_ Positive LVDS differential data input	
17	R3_CLKN	THIRD_ Negative LVDS differential clock input	
18	R3_CLKP	THIRD_ Positive LVDS differential clock input	
19	GND	Power Ground	
20	RXIN33_N	THIRD_ Negative LVDS differential data input	
21	RXIN33_P	THIRD_ Positive LVDS differential data input	
22	RXIN34_N	THIRD_ Negative LVDS differential data input	
23	RXIN34_P	THIRD_ Positive LVDS differential data input	
24	GND	Power Ground	
25	RXIN40_N	FOURTH_ Negative LVDS differential data input	
26	RXIN40_P	FOURTH_ Positive LVDS differential data input	
27	RXIN41_N	FOURTH_ Negative LVDS differential data input	
28	RXIN41_P	FOURTH_ Positive LVDS differential data input	
29	GND	Power Ground	
30	RXIN42_N	FOURTH_ Negative LVDS differential data input	
31	RXIN42_P	FOURTH_ Positive LVDS differential data input	
32	R4_CLKN	FOURTH_ Negative LVDS differential clock input	
33	R4_CLKP	FOURTH_ Positive LVDS differential clock input	
34	GND	Power Ground	
35	RXIN43_N	FOURTH_ Negative LVDS differential data input	
36	RXIN43_P	FOURTH_ Positive LVDS differential data input	
37	RXIN44_N	FOURTH_ Negative LVDS differential data input	
38	RXIN44_P	FOURTH_ Positive LVDS differential data input	
39	GND	Power Ground	
40	NC	No connection (for AUO test only. Do not connect)	
41	NC	No connection (for AUO test only. Do not connect)	

Note1: Pin number start from left side

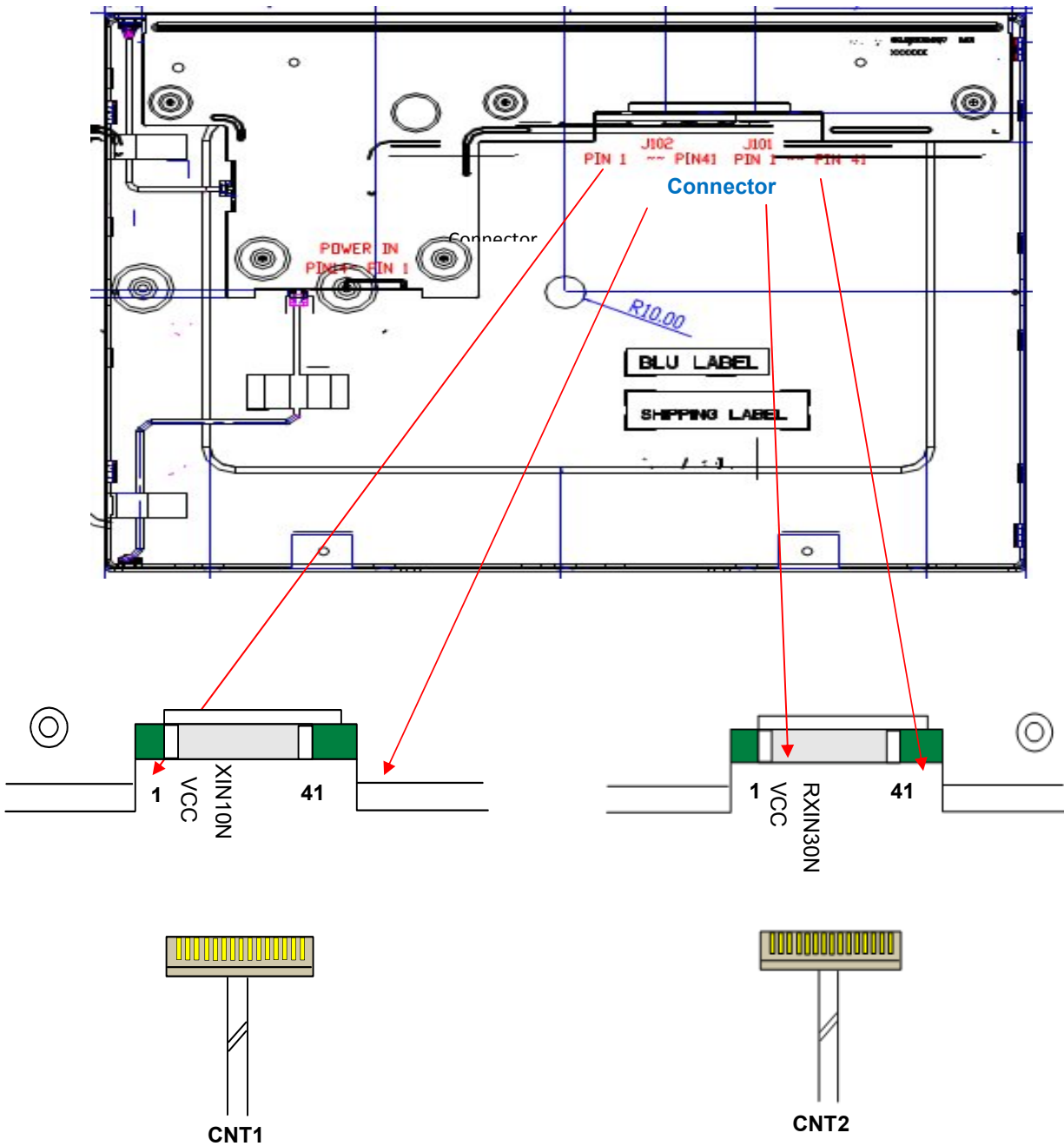

Note2: Input signals of port 1 to port 4 clocks shall be the same timing.

Note3: Please follow VESA.



6.4 Interface Timing

6.4.1 Timing Characteristics

Signal	Item	Symbol	Min	Typ	Max	Unit
Vertical Section	Period	Tv	1547	1612	1628	Th
	Active	Tdisp(v)	1536	1536	1536	Th
	Blanking	Tbp(v)+Tfp(v)+PWvs	11	76	92	Th
Horizontal Section	Period	Th	640	672	700	Tclk
	Active	Tdisp(h)	512	512	512	Tclk
	Blanking	Tbp(h)+Tfp(h)+PWhs	128	160	188	Tclk
Clock	Period	Tclk	1515	1538	1667	ns
	Frequency	Freq.	49.5	64.9	79.7	MHz
Frame Rate	Frequency	1/Tv	50	60	70	Hz

Note : DE mode only.

6.4.2 Timing Diagram

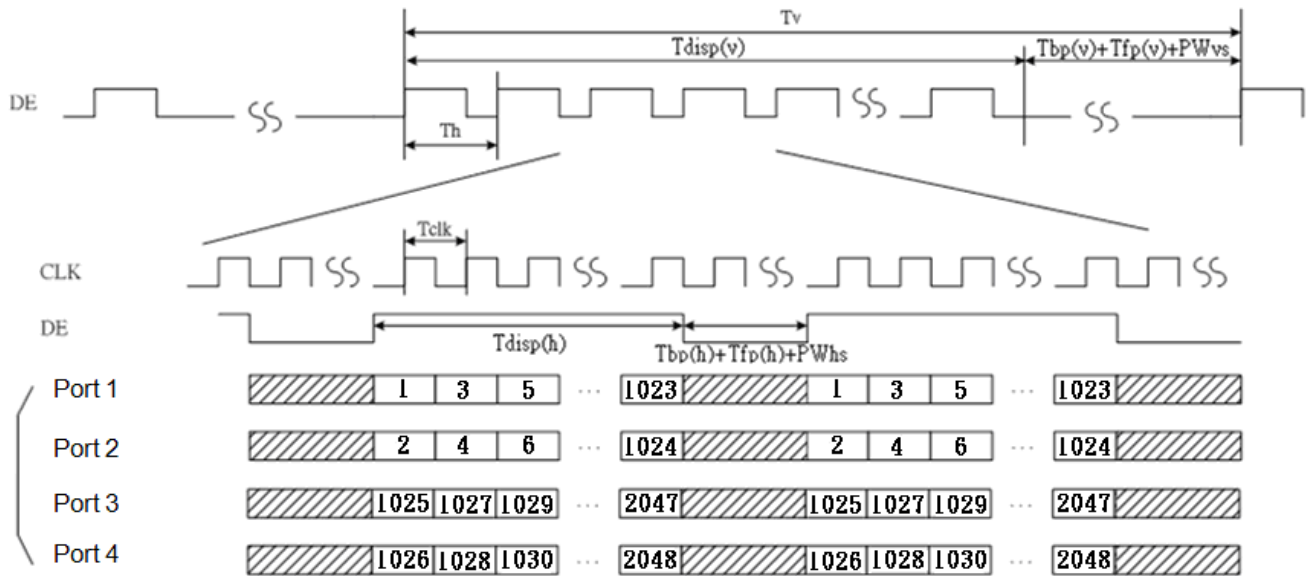

6.5 Power ON/OFF Sequence

VDD power and LED on/off sequence is as follows. Interface signals are also shown in the chart. Signals from any system shall be Hi-Z state or low level when VDD is off.

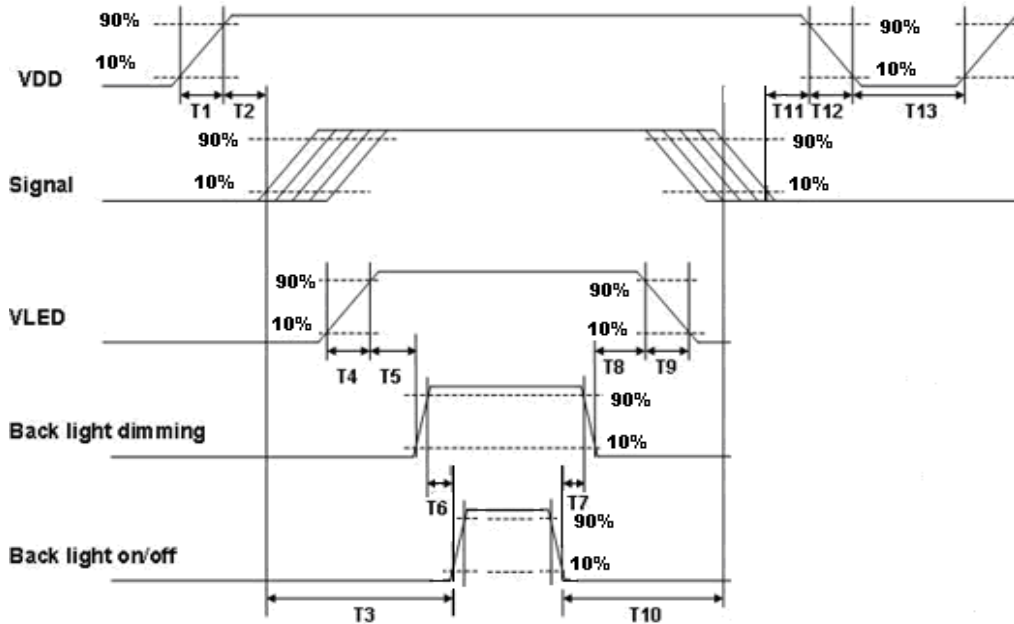

Power Sequence Timing

Power Sequence Timing				
Parameter	Value			Units
	Min.	Typ.	Max.	
T1	0.5	-	10	ms
T2	30	40	50	
T3	200	-	--	
T4	0.5	-	10	
T5	10	-	-	
T6	10	-	-	
T7	0	-	-	
T8	10	-	-	
T9	-	-	10	
T10	110	-	-	
T11	0	16	50	
T12	0	-	10	
T13	1000	-	-	



7. Connector & Pin Assignment

Physical interface is described as for the connector on module. These connectors are capable of accommodating the following signals and will be following components.

7.1 TFT LCD Module

7.1.1 Connector

Connector Name / Designation	Interface Connector / Interface card
Manufacturer	HIROSE
Type Part Number	FX15SC-41S-0.5SH (HIROSE)
Mating Housing Part Number	FX15S-41P-C (HIROSE)

7.1.2 Pin Assignment

CNT1

Pin#	Signal Name	Pin#	Signal Name
1	VCC	22	RXIN14_N
2	VCC	23	RXIN14_P
3	VCC	24	GND
4	VCC	25	RXIN20_N
5	VCC	26	RXIN20_P
6	GND	27	RXIN21_N
7	GND	28	RXIN21_P
8	GND	29	GND
9	GND	30	RXIN22_N
10	RXIN10_N	31	RXIN22_P
11	RXIN10_P	32	R2_CLKN
12	RXIN11_N	33	R2_CLKP
13	RXIN11_P	34	GND
14	GND	35	RXIN23_N



15	RXIN12_N	36	RXIN23_P
16	RXIN12_P	37	RXIN24_N
17	R1_CLKN	38	RXIN24_P
18	R1_CLKP	39	GND
19	GND	40	NC
20	RXIN13_N	41	NC
21	RXIN13_P		

CNT2

Pin#	Signal Name	Pin#	Signal Name
1	VCC	22	RXIN34_N
2	VCC	23	RXIN34_P
3	VCC	24	GND
4	VCC	25	RXIN40_N
5	VCC	26	RXIN40_P
6	GND	27	RXIN41_N
7	GND	28	RXIN41_P
8	GND	29	GND
9	GND	30	RXIN42_N
10	RXIN30_N	31	RXIN42_P
11	RXIN30_P	32	R4_CLKN
12	RXIN31_N	33	R4_CLKP
13	RXIN31_P	34	GND
14	GND	35	RXIN43_N
15	RXIN32_N	36	RXIN43_P
16	RXIN32_P	37	RXIN44_N
17	R3_CLKN	38	RXIN44_P
18	R3_CLKP	39	GND
19	GND	40	NC
20	RXIN33_N	41	NC
21	RXIN33_P		

7.2 Backlight Unit

Physical interface is described as for the connector on module. These connectors are capable of accommodating the following signals and will be following components.

Connector Name / Designation	LED Connector / Backlight
Manufacturer	JST
Type Part Number	S14B-PH-SM6-K-TB(HF)
Mating Type Part Number	PHR-14

7.2.1 Signal for LED connector

Pin #	Symbol	Pin Description
1	VDD	Power +24V
2	VDD	Power +24V
3	VDD	Power +24V
4	VDD	Power +24V
5	VDD	Power +24V
6	GND	GND
7	GND	GND
8	GND	GND
9	GND	GND
10	GND	GND
11	NC	Do not connect
12	EN	Enable(0V:disable, 2.5~5V:Enable)
13	Analog Control Voltage	Analog Control Voltage 0~3V
14	Dimming	PWM; duty 10%~ 100%

Note:

Two kind types for adjusting brightness: PWM and Analog.

If pin 13 or pin 14 not use, please do not connect.



8. Reliability Test

Environment test conditions are listed as following table.

Items	Required Condition	Note
Temperature Humidity Bias (THB)	Ta= 60°C, 75%RH, 300hours	1
High Temperature Operation (HTO)	Ta= 60°C, 300hours	1
Low Temperature Operation (LTO)	Ta= 0°C, 300hours	1
High Temperature Storage (HTS)	Ta= 60°C, 300hours	
Low Temperature Storage (LTS)	Ta= -20°C, 300hours	
Vibration Test (Non-operation)	Acceleration: 1.5 G Wave: Random Frequency: 10 - 200Hz Sweep: 30 Minutes each Axis (X, Y, Z)	
Shock Test (Non-operation)	Acceleration: 50 G Wave: Half-sine Active Time: 20 ms Direction: ±X, ±Y, ±Z (one time for each Axis)	
Drop Test	Height: 60 cm, package test	
Thermal Shock Test (TST)	-20 °C /30min, 60/°C 30min, 100 cycles	2
On/Off Test	On/10sec, Off/10sec, 30,000 cycles	
ESD (Electrostatic Discharge)	Contact Discharge: ± 8KV, 150pF(330Ω) 1sec, 9 points, 25 times/ point.	3
	Air Discharge: ± 15KV, 150pF(330Ω) 1sec 9 points, 25 times/ point.	
Altitude Test	Operation:10,000 ft Non-Operation:30,000 ft	

Note 1: Luminance: 450nits at luminance control.

Note 2: The TFT-LCD module will not sustain damage after being subjected to 100 cycles of rapid temperature change. A cycle of rapid temperature change consists of varying the temperature from -20°C to 60°C, and back again. Power is not applied during the test. After temperature cycling, the unit is placed in normal room ambient for at least 4 hours before power on.

Note 3: According to EN61000-4-2 , ESD class B: Some performance degradation allowed. No data lost. Self-recoverable. No hardware failures.

Note 4:

- Water condensation is not allowed for each test items.
- Each test is done by new TFT-LCD module. Don't use the same TFT-LCD module repeatedly for reliability test.
- The reliability test is performed only to examine the TFT-LCD module capability.
- To inspect TFT-LCD module after reliability test, please store it at room temperature and room humidity for 24 hours at least in advance.
- No function failure occurs or no display malfunctions.

9. Shipping Label and Packaging

9.1 Shipping Label

The label is on the panel as shown below:



Note 1: For Pb Free products, AUO will add  for identification.

Note 2: For RoHS compatible products, AUO will add  for identification.

Note 3: For China RoHS compatible products, AUO will add  for identification.

Note 4: The Green Mark will be presented only when the green documents have been ready by AUO Internal Green Team.

9.2 Packaging

Packaging material

FILM PROTECT
BAG ANTI-STATIC
TAPE
TAPE CREPED PAPER
PACKING CARTON
LABEL SPEC
LABEL CARTON.
CUSHION PACKING

Packing instruction

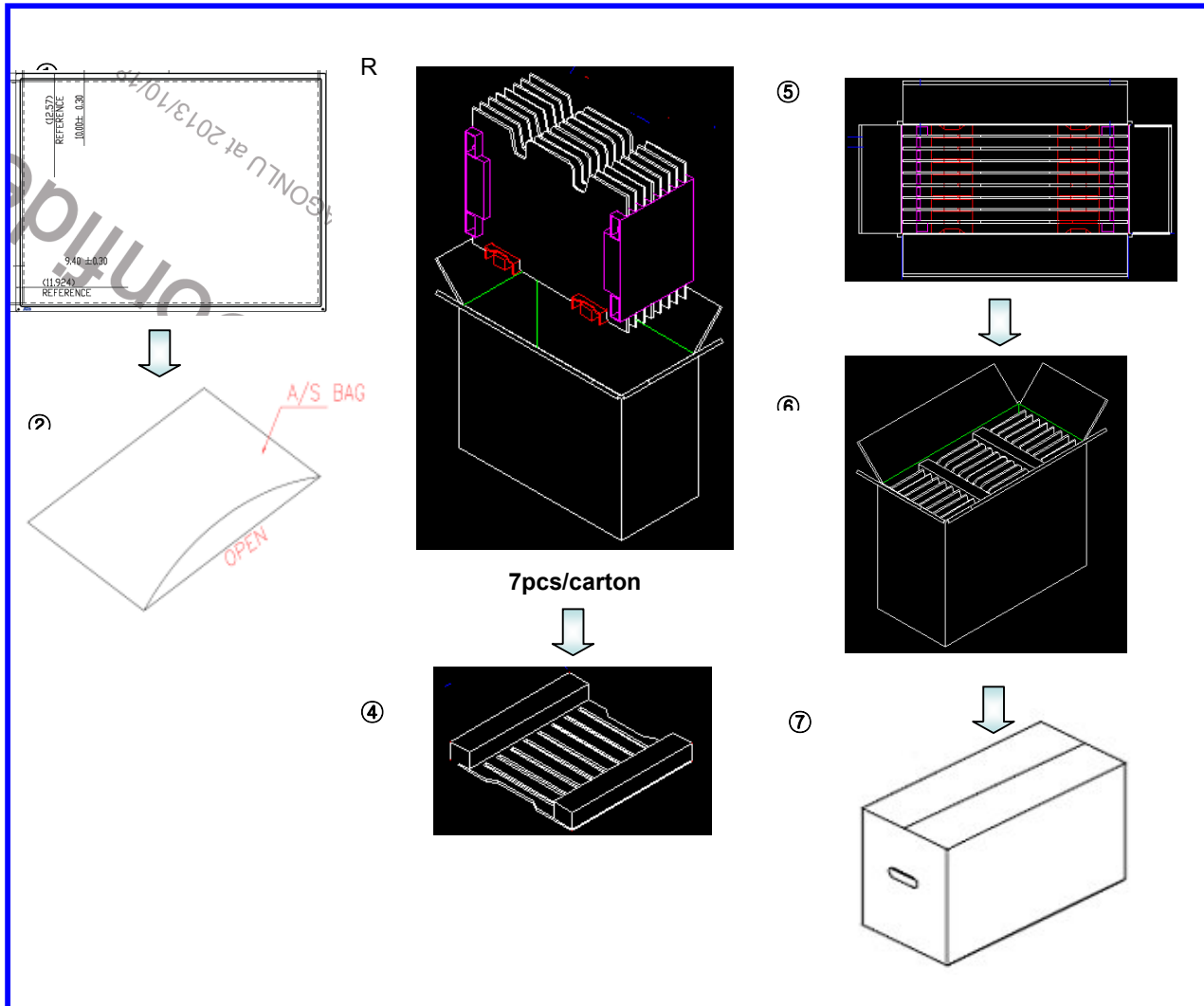

Max capacity : 6 TFT-LCD module per carton

Max weight: TBD per carton

Outside dimension of carton: 550mm(L)* 264mm(W)*432mm(H)

Pallet size : 1150 mm * 840 mm * 140mm

Box Stacked

Module by air : (2 *3) *3 layers , one pallet put 18 boxes , total 108 pcs module

Module by sea : (2 *3) *3 layers + (2 *3) *1 layers , two pallet put 24 boxes , total 144 pcs module

Module by sea_HQ : (2 *3) *3 layers+(2 *3) *2 layers, two pallet put 30 boxes, total 180 pcs module



10. Mechanical Characteristic

Front View

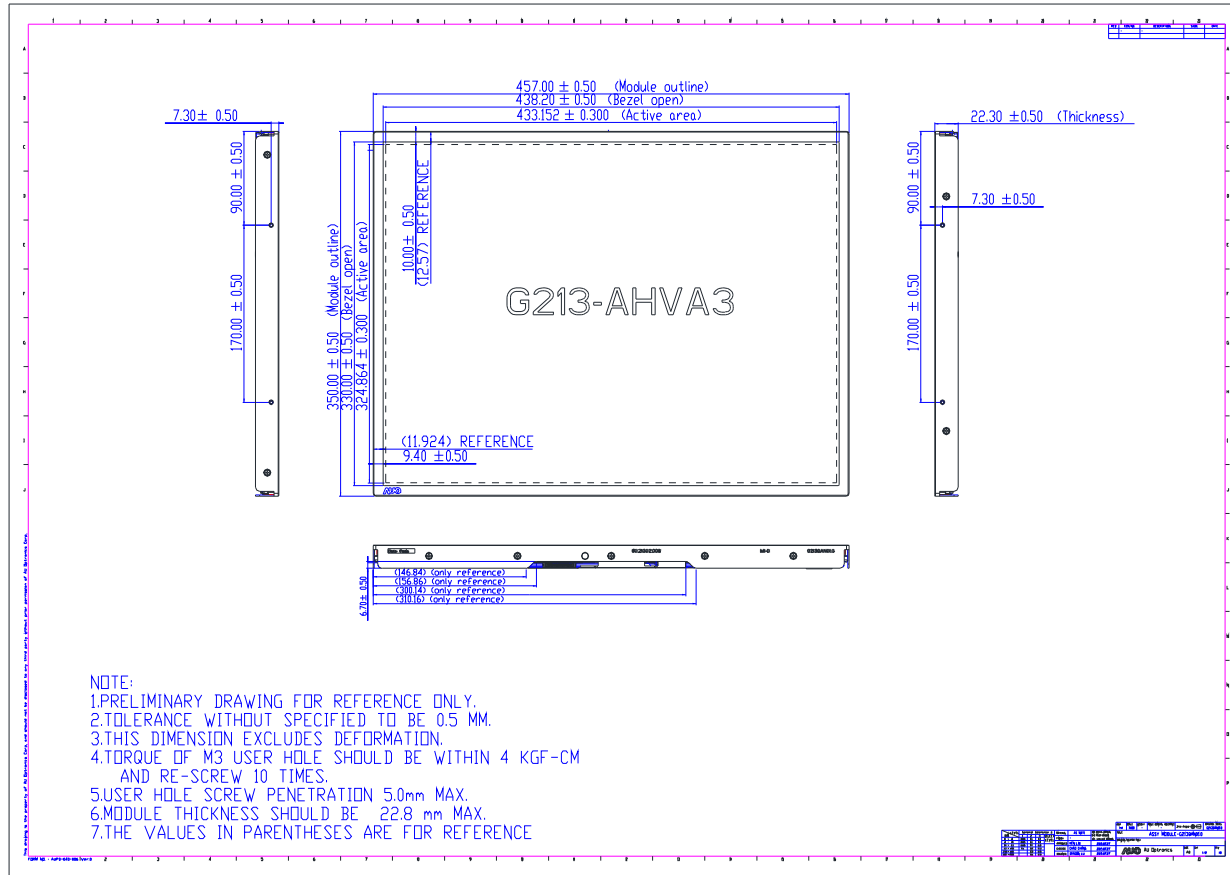



Product Specification

G213QAN01.0

AU OPTRONICS CORPORATION

Back view

