

TFT-DISPLAY DATASHEET

AUO
Model: G185XW01 V2

BRIEF SPEC.:

Main Feature

Landscape Type

White LED backlighth

Wide Aspect Ratio

Active Screen Area

409.8 x 230.4 (mm)

Diagonal | Format

18,5" | 16:9

Resolution

1366 x 768

Colors

16.7 M (8 Bit)

Backlight

White

Brightness

450 cd/m²

LED Life Time

50K (h)

Interface

LVDS

Viewing Angle

85/85 L/R 80/80

Touchscreen

no

Power Supply

5.0 V (Typ.)

Module Outline

430.4 x 254.7 x 12.7 (mm)

Operation Temperature

-0 ... +60°C

Storage Temperature

-20... +60 °C

Surface Treatment

Anti-Glare Hard-coating (3H)



() Preliminary Specification
(v) Final Specification

Module	18.5" Color TFT-LCD
Model Name	G185XW01 V2

Customer	Date
_____	_____
Approved by	
_____	_____

Note: This Specification is subject to change without notice.

Approved by	Date
<u>Crystal Hsieh</u>	<u>2015/10/12</u>
Prepared by	
<u>Athena Wu</u>	<u>2015/10/12</u>



Desktop Display Business Group /
AU Optronics corporation

Contents

1.0 Handling Precautions	5
2.0 General Description	6
2.1 Display Characteristics.....	6
2.2 Optical Characteristics	7
3.0 Functional Block Diagram	11
4.0 Absolute Maximum Ratings	12
4.1 TFT LCD Module.....	12
4.2 Absolute Ratings of Environment.....	12
5.0 Electrical characteristics	13
5.1 TFT LCD Module.....	13
5.1.1 Power Specification	13
5.1.2 Signal Electrical Characteristics.....	14
5.2 Backlight Unit.....	15
6.0 Signal Characteristic	16
6.1 Pixel Format Image.....	16
6.2 The input data format.....	17
6.3 Signal Description	18
6.4 Timing Characteristics.....	20
6.5 Timing diagram	21
6.6 Power ON/OFF Sequence	22
7.0 Connector & Pin Assignment	23
7.1 TFT LCD Module.....	23
7.2 LED Backlight Unit: LED Driver Connector	23
7.3 LED Driver Connector Pin Assignment	24
8.0 Reliability Test	25
9.0 Shipping Label & Packaging	26
9.1 Shipping Label	26
9.2 Packaging	27
9.3 Palletizing.....	28
10.0 Mechanical Characteristics	29
11 Safety	31
11.1 Sharp Edge Requirements	31
11.2 Materials.....	31
11.3 Capacitors	31
11.4 National Test Lab Requirement.....	31

Record of Revision

Version & Date	Page	Old description	New Description																																																																				
0.0 2015/01/16	All		Preliminary spec																																																																				
1.0 2015/06/25	5	<p>2.1 Display Characteristics</p> <table border="1"> <tr> <td>Temperature Range</td> <td>[°C]</td> <td>0 to +50</td> </tr> <tr> <td>Operating</td> <td>[°C]</td> <td>-20 to +60</td> </tr> <tr> <td>Storage (Shipping)</td> <td>[°C]</td> <td></td> </tr> </table>	Temperature Range	[°C]	0 to +50	Operating	[°C]	-20 to +60	Storage (Shipping)	[°C]		<p>2.1 Display Characteristics</p> <table border="1"> <tr> <td>Temperature Range</td> <td>[°C]</td> <td>0 to +60(+60°C as panel surface temperature)</td> </tr> <tr> <td>Operating</td> <td>[°C]</td> <td>-20 to +60</td> </tr> <tr> <td>Storage (Shipping)</td> <td>[°C]</td> <td></td> </tr> </table>	Temperature Range	[°C]	0 to +60(+60°C as panel surface temperature)	Operating	[°C]	-20 to +60	Storage (Shipping)	[°C]																																																			
Temperature Range	[°C]	0 to +50																																																																					
Operating	[°C]	-20 to +60																																																																					
Storage (Shipping)	[°C]																																																																						
Temperature Range	[°C]	0 to +60(+60°C as panel surface temperature)																																																																					
Operating	[°C]	-20 to +60																																																																					
Storage (Shipping)	[°C]																																																																						
	6	<p>2.2 Optical Characteristics</p> <table border="1"> <tr> <td rowspan="7">Color / Chromaticity Coordinates (CIE)</td> <td>Red x</td> <td>TBD</td> <td>TBD</td> <td>TBD</td> </tr> <tr> <td>Red y</td> <td>TBD</td> <td>TBD</td> <td>TBD</td> </tr> <tr> <td>Green x</td> <td>TBD</td> <td>TBD</td> <td>TBD</td> </tr> <tr> <td>Green y</td> <td>TBD</td> <td>TBD</td> <td>TBD</td> </tr> <tr> <td>Blue x</td> <td>TBD</td> <td>TBD</td> <td>TBD</td> </tr> <tr> <td>Blue y</td> <td>TBD</td> <td>TBD</td> <td>TBD</td> </tr> <tr> <td>White x</td> <td>0.263</td> <td>0.313</td> <td>0.363</td> </tr> <tr> <td>Color Coordinates (CIE) White</td> <td>White y</td> <td>0.279</td> <td>0.329</td> <td>0.379</td> </tr> </table>	Color / Chromaticity Coordinates (CIE)	Red x	TBD	TBD	TBD	Red y	TBD	TBD	TBD	Green x	TBD	TBD	TBD	Green y	TBD	TBD	TBD	Blue x	TBD	TBD	TBD	Blue y	TBD	TBD	TBD	White x	0.263	0.313	0.363	Color Coordinates (CIE) White	White y	0.279	0.329	0.379	<p>2.2 Optical Characteristics</p> <table border="1"> <tr> <td rowspan="7">Color / Chromaticity Coordinates (CIE)</td> <td>Red x</td> <td>0.583</td> <td>0.633</td> <td>0.683</td> </tr> <tr> <td>Red y</td> <td>0.296</td> <td>0.346</td> <td>0.396</td> </tr> <tr> <td>Green x</td> <td>0.281</td> <td>0.331</td> <td>0.381</td> </tr> <tr> <td>Green y</td> <td>0.550</td> <td>0.600</td> <td>0.650</td> </tr> <tr> <td>Blue x</td> <td>0.098</td> <td>0.148</td> <td>0.198</td> </tr> <tr> <td>Blue y</td> <td>0.016</td> <td>0.066</td> <td>0.116</td> </tr> <tr> <td>White x</td> <td>0.263</td> <td>0.313</td> <td>0.363</td> </tr> <tr> <td>Color Coordinates (CIE) White</td> <td>White y</td> <td>0.279</td> <td>0.329</td> <td>0.379</td> </tr> </table>	Color / Chromaticity Coordinates (CIE)	Red x	0.583	0.633	0.683	Red y	0.296	0.346	0.396	Green x	0.281	0.331	0.381	Green y	0.550	0.600	0.650	Blue x	0.098	0.148	0.198	Blue y	0.016	0.066	0.116	White x	0.263	0.313	0.363	Color Coordinates (CIE) White	White y	0.279	0.329	0.379
Color / Chromaticity Coordinates (CIE)	Red x	TBD		TBD	TBD																																																																		
	Red y	TBD		TBD	TBD																																																																		
	Green x	TBD		TBD	TBD																																																																		
	Green y	TBD		TBD	TBD																																																																		
	Blue x	TBD		TBD	TBD																																																																		
	Blue y	TBD		TBD	TBD																																																																		
	White x	0.263	0.313	0.363																																																																			
Color Coordinates (CIE) White	White y	0.279	0.329	0.379																																																																			
Color / Chromaticity Coordinates (CIE)	Red x	0.583	0.633	0.683																																																																			
	Red y	0.296	0.346	0.396																																																																			
	Green x	0.281	0.331	0.381																																																																			
	Green y	0.550	0.600	0.650																																																																			
	Blue x	0.098	0.148	0.198																																																																			
	Blue y	0.016	0.066	0.116																																																																			
	White x	0.263	0.313	0.363																																																																			
Color Coordinates (CIE) White	White y	0.279	0.329	0.379																																																																			
	10	<p>3.0 Functional Block Diagram</p> <p>I/F PCB Interface: FI-XPB30SRLA-HF11 (JAE)</p> <p>Mating Type: FI-X30HL (JAE)(Locked Type)</p>	<p>3.0 Functional Block Diagram</p> <p>I/F PCB Interface: 187145-30091-3 (P-TWO)</p> <p>Mating Type: 117 Series (P-TWO)</p>																																																																				
	11	<p>4.2 Absolute Ratings of Environment</p> <table border="1"> <thead> <tr> <th>Item</th> <th>Symbol</th> <th>Min.</th> <th>Max.</th> <th>Unit</th> <th>Conditions</th> </tr> </thead> <tbody> <tr> <td>Operating Temperature</td> <td>TOP</td> <td>0</td> <td>+50</td> <td>[°C]</td> <td rowspan="4">Note 3 & 4</td> </tr> <tr> <td>Operation Humidity</td> <td>HOP</td> <td>5</td> <td>90</td> <td>[%RH]</td> </tr> <tr> <td>Storage Temperature</td> <td>TST</td> <td>-20</td> <td>+60</td> <td>[°C]</td> </tr> <tr> <td>Storage Humidity</td> <td>HST</td> <td>5</td> <td>90</td> <td>[%RH]</td> </tr> </tbody> </table>	Item	Symbol	Min.	Max.	Unit	Conditions	Operating Temperature	TOP	0	+50	[°C]	Note 3 & 4	Operation Humidity	HOP	5	90	[%RH]	Storage Temperature	TST	-20	+60	[°C]	Storage Humidity	HST	5	90	[%RH]	<p>4.2 Absolute Ratings of Environment</p> <table border="1"> <thead> <tr> <th>Item</th> <th>Symbol</th> <th>Min.</th> <th>Max.</th> <th>Unit</th> <th>Conditions</th> </tr> </thead> <tbody> <tr> <td>Operating Temperature</td> <td>TOP</td> <td>0</td> <td>+60</td> <td>[°C]</td> <td rowspan="4">Note 3 & 4</td> </tr> <tr> <td>Operation Humidity</td> <td>HOP</td> <td>5</td> <td>90</td> <td>[%RH]</td> </tr> <tr> <td>Storage Temperature</td> <td>TST</td> <td>-20</td> <td>+60</td> <td>[°C]</td> </tr> <tr> <td>Storage Humidity</td> <td>HST</td> <td>5</td> <td>90</td> <td>[%RH]</td> </tr> </tbody> </table>	Item	Symbol	Min.	Max.	Unit	Conditions	Operating Temperature	TOP	0	+60	[°C]	Note 3 & 4	Operation Humidity	HOP	5	90	[%RH]	Storage Temperature	TST	-20	+60	[°C]	Storage Humidity	HST	5	90	[%RH]														
Item	Symbol	Min.	Max.	Unit	Conditions																																																																		
Operating Temperature	TOP	0	+50	[°C]	Note 3 & 4																																																																		
Operation Humidity	HOP	5	90	[%RH]																																																																			
Storage Temperature	TST	-20	+60	[°C]																																																																			
Storage Humidity	HST	5	90	[%RH]																																																																			
Item	Symbol	Min.	Max.	Unit	Conditions																																																																		
Operating Temperature	TOP	0	+60	[°C]	Note 3 & 4																																																																		
Operation Humidity	HOP	5	90	[%RH]																																																																			
Storage Temperature	TST	-20	+60	[°C]																																																																			
Storage Humidity	HST	5	90	[%RH]																																																																			
	22	<p>7.0 Connector & Pin Assignment</p> <p>7.1 TFT LCD Module</p> <table border="1"> <tr> <td>Connector Name / Designation</td> <td>Interface Connector / Interface card</td> </tr> <tr> <td>Manufacturer</td> <td>JAE</td> </tr> <tr> <td>Type Part Number</td> <td>FI-XPB30SRLA-HF11</td> </tr> <tr> <td>Mating Housing Part Number</td> <td>FI-X30HL (JAE) (Locked Type) FI-X30H (JAE) (Unlocked Type)</td> </tr> </table>	Connector Name / Designation	Interface Connector / Interface card	Manufacturer	JAE	Type Part Number	FI-XPB30SRLA-HF11	Mating Housing Part Number	FI-X30HL (JAE) (Locked Type) FI-X30H (JAE) (Unlocked Type)	<p>7.0 Connector & Pin Assignment</p> <p>7.1 TFT LCD Module</p> <table border="1"> <tr> <td>Connector Name / Designation</td> <td>Interface Connector / Interface card</td> </tr> <tr> <td>Manufacturer</td> <td>P-TWO</td> </tr> <tr> <td>Type Part Number</td> <td>187145-30091-3</td> </tr> <tr> <td>Mating Housing Part Number</td> <td>117 Series</td> </tr> </table>	Connector Name / Designation	Interface Connector / Interface card	Manufacturer	P-TWO	Type Part Number	187145-30091-3	Mating Housing Part Number	117 Series																																																				
Connector Name / Designation	Interface Connector / Interface card																																																																						
Manufacturer	JAE																																																																						
Type Part Number	FI-XPB30SRLA-HF11																																																																						
Mating Housing Part Number	FI-X30HL (JAE) (Locked Type) FI-X30H (JAE) (Unlocked Type)																																																																						
Connector Name / Designation	Interface Connector / Interface card																																																																						
Manufacturer	P-TWO																																																																						
Type Part Number	187145-30091-3																																																																						
Mating Housing Part Number	117 Series																																																																						
	24	<p>8.0 Reliability Test</p> <table border="1"> <thead> <tr> <th>Items</th> <th>Required Condition</th> </tr> </thead> <tbody> <tr> <td>Temperature Humidity Bias (THB)</td> <td>Ta= 50°C, 80%RH, 300hours</td> </tr> <tr> <td>High Temperature Operation (HTO)</td> <td>Ta= 50°C, 300hours</td> </tr> </tbody> </table>	Items	Required Condition	Temperature Humidity Bias (THB)	Ta= 50°C, 80%RH, 300hours	High Temperature Operation (HTO)	Ta= 50°C, 300hours	<p>8.0 Reliability Test</p> <table border="1"> <thead> <tr> <th>Items</th> <th>Required Condition</th> </tr> </thead> <tbody> <tr> <td>Temperature Humidity Bias (THB)</td> <td>Ta= 50°C, 80%RH, 300hours</td> </tr> <tr> <td>High Temperature Operation (HTO)</td> <td>Ta= 60°C, 300hours</td> </tr> </tbody> </table>	Items	Required Condition	Temperature Humidity Bias (THB)	Ta= 50°C, 80%RH, 300hours	High Temperature Operation (HTO)	Ta= 60°C, 300hours																																																								
Items	Required Condition																																																																						
Temperature Humidity Bias (THB)	Ta= 50°C, 80%RH, 300hours																																																																						
High Temperature Operation (HTO)	Ta= 50°C, 300hours																																																																						
Items	Required Condition																																																																						
Temperature Humidity Bias (THB)	Ta= 50°C, 80%RH, 300hours																																																																						
High Temperature Operation (HTO)	Ta= 60°C, 300hours																																																																						
1.1 2015/10/12	5	<p>2.1 Display Characteristics</p> <p>White Luminance (Center) : 400 nits</p>	<p>2.1 Display Characteristics</p> <p>White Luminance (Center) : 450 nits</p>																																																																				
	7	<p>2.2 Optical Characteristics</p> <p>Central Luminance [cd/m²]</p> <p>Min:320nits ; Typ:400nits</p>	<p>2.2 Optical Characteristics</p> <p>Central Luminance [cd/m²]</p> <p>Min:360nits ; Typ:450nits</p>																																																																				
	11		<p>4.2 Absolute Ratings of Environment</p> <p>Note 4: Operation Temperature + 60°C is defined as panel surface temperature.</p>																																																																				

	24	<p>8.0 Reliability Test Ta=60oC, 300hours</p>	<p>8.0 Reliability Test Tgs=60oC, 300hours, For panel surface temp. <i>Note 3:</i> Tgs = Panel surface temperature <i>Note 4:</i> No function occurs Mura shall be ignored after high temperature reliability test.</p>
	25	<p>9.1 Shipping Label</p> 	<p>9.1 Shipping Label</p> 

1.0 Handling Precautions

- 1) Since front polarizer is easily damaged, pay attention not to scratch it.
- 2) Be sure to turn off power supply when inserting or disconnecting from input connector.
- 3) Wipe off water drop immediately. Long contact with water may cause discoloration or spots.
- 4) When the panel surface is soiled, wipe it with absorbent cotton or other soft cloth.
- 5) Since the panel is made of glass, it may break or crack if dropped or bumped on hard surface.
- 6) Since CMOS LSI is used in this module, take care of static electricity and insure human earth when handling.
- 7) Do not open or modify the Module Assembly.
- 8) Do not press the reflector sheet at the back of the module to any directions.
- 9) In case if a Module has to be put back into the packing container slot after it was taken out from the container, do not press the center of LED lightbar edge. Instead, press at the far ends of the LED light bar edge softly. Otherwise the TFT Module may be damaged.
- 10) At the insertion or removal of the Signal Interface Connector, be sure not to rotate nor tilt the Interface Connector of the TFT Module.
- 11) After installation of the TFT Module into an enclosure, do not twist nor bend the TFT Module even momentarily. While designing the enclosure, it should be taken into consideration that no bending/twisting forces are applied to the TFT Module from outside. Otherwise the TFT Module may be damaged.
- 12) Small amount of materials having no flammability grade is used in the LCD module. The LCD module should be supplied by power complied with requirements of Limited Power Source (IEC60950-1 or UL1950-1), or be applied exemption.



2.0 General Description

This specification applies to the 18.5 inch-wide Color a-Si TFT-LCD Module G185XW01 V2. The display supports the WXGA [1366(H) x 768(V)] screen format and 16.7M colors (RGB 6-bits + Hi-FRC data). All input signals are LVDS interface compatible.

2.1 Display Characteristics

The following items are characteristics summary on the table under 25°C condition:

ITEMS	Unit	SPECIFICATIONS
Screen Diagonal	[mm]	470.1(18.51")
Active Area	[mm]	409.8 (H) x 230.4 (V)
Pixels H x V		1366(x3) x 768
Pixel Pitch	[um]	300 (per one triad) × 300
Pixel Arrangement		R.G.B. Vertical Stripe
Display Mode		TN Mode, Normally White
White Luminance (Center)	[cd/m ²]	450 cd/m ² (Typ.)
Contrast Ratio		1000 (Typ.)
Optical Response Time	[msec]	5ms (Typ., on/off)
Nominal Input Voltage VDD	[Volt]	+5.0 V (Typ)
Power Consumption (VDD line + LED line)	[Watt]	13.5W (Typ.) (Pdd=4.5W, PLED=9W)
Weight	[Grams]	1550(Max)
Physical Size	[mm]	430.4 (W) x 254.7 (H) Typ. x 12.7(D)Typ
Electrical Interface		One channel LVDS
Support Color		16.7M colors, RGB 6-bit +Hi- FRC
Surface Treatment		Anti-Glare, 3H
RoHS Compliance		RoHS Compliance
Temperature Range		
Operating	[°C]	0 to +60(+60°C as panel surface temperture)
Storage (Shipping)	[°C]	-20 to +60

2.2 Optical Characteristics

The optical characteristics are measured under stable conditions at 25°C:

Item	Unit	Conditions	Min.	Typ.	Max.	Note
Viewing Angle	[degree]	Horizontal (Right) CR = 10 (Left)	150	170	- -	2
		Vertical (Up) CR = 10 (Down)	140	160	- -	
Contrast ratio		Normal Direction	600	1000	-	3
Response Time	[msec]	Raising Time (T_{rR})	-	3.5	5	4
		Falling Time (T_{rF})	-	1.5	2.5	
		Raising + Falling	-	5	7.5	
Color / Chromaticity Coordinates (CIE)		Red x	0.583	0.633	0.683	5
		Red y	0.296	0.346	0.396	
		Green x	0.281	0.331	0.381	
		Green y	0.550	0.600	0.650	
		Blue x	0.098	0.148	0.198	
		Blue y	0.016	0.066	0.116	
Color Coordinates (CIE) White		White x	0.263	0.313	0.363	5
		White y	0.279	0.329	0.379	
Central Luminance	[cd/m ²]		360	450	-	6
Luminance Uniformity	[%]		65	70	-	7
Crosstalk (in 60Hz)	[%]				1.5	8
Flicker	dB				-20	9
Color Gamut	%			68		

Note 1: Measurement method

The LCD module should be stabilized at given temperature for 30 minutes to avoid abrupt temperature change during measuring (at surface 35°C). In order to stabilize the luminance, the measurement should be executed after lighting Backlight for 30 minutes in a stable, windless and dark room.

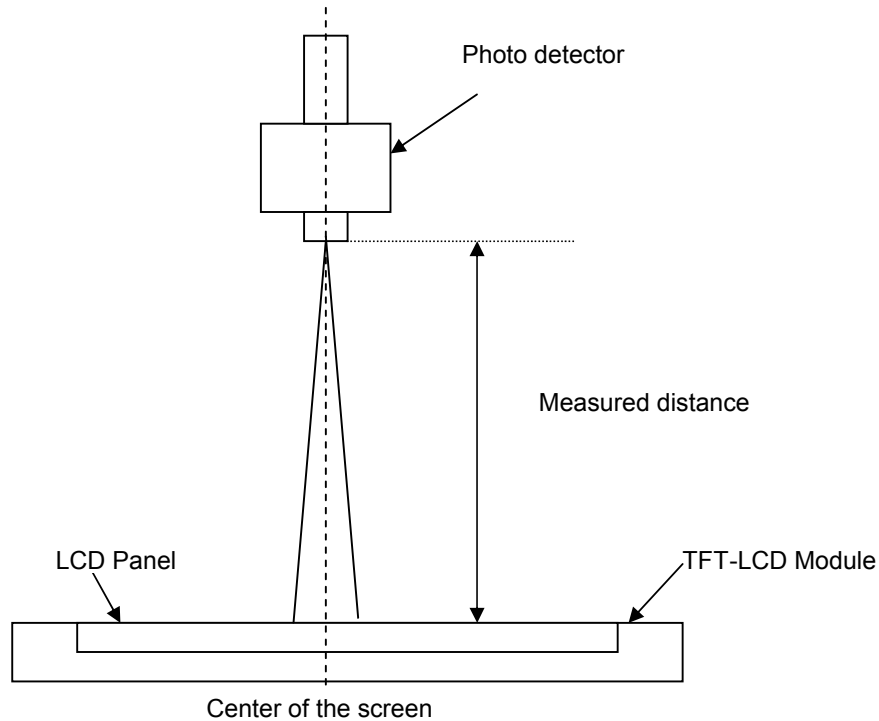

Note 2: Definition of viewing angle measured by ELDIM (EZContrast 88)

Viewing angle is the measurement of contrast ratio ≥ 10 , at the screen center, over a 180° horizontal and 180° vertical range (off-normal viewing angles). The 180° viewing angle range is broken down as follows; 90° (θ) horizontal left and right and 90° (ϕ) vertical, high (up) and low (down). The measurement direction is typically perpendicular to the display surface with the screen rotated about its center to develop the desired measurement viewing angle.

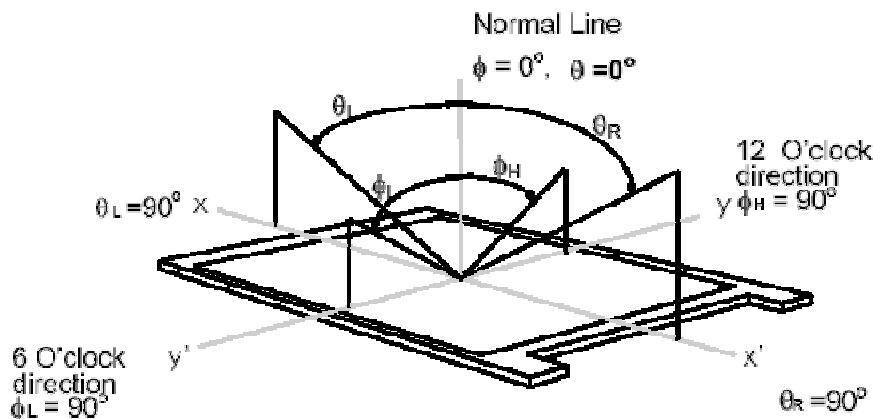

Note 3: Contrast ratio is measured by TOPCON SR-3

Note 4: Definition of Response time measured by Westar TRD-100A

The output signals of photo detector are measured when the input signals are changed from “Full Black” to “Full White” (rising time, Tr_R), and from “Full White” to “Full Black” (falling time, Tr_F), respectively. The response time is interval between the 10% and 90% (1 frame at 60 Hz) of amplitudes. $Tr_R + Tr_F = 5$ msec (typ.).

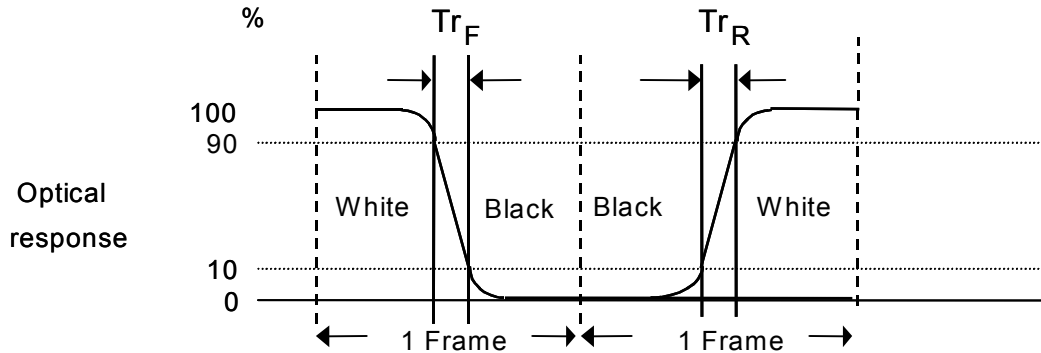

Note 5: Color chromaticity and coordinates (CIE) is measured by TOPCON SR-3

Note 6: Central luminance is measured by TOPCON SR-3

Note 7: Luminance uniformity of these 9 points is defined as below and measured by TOPCON SR-3

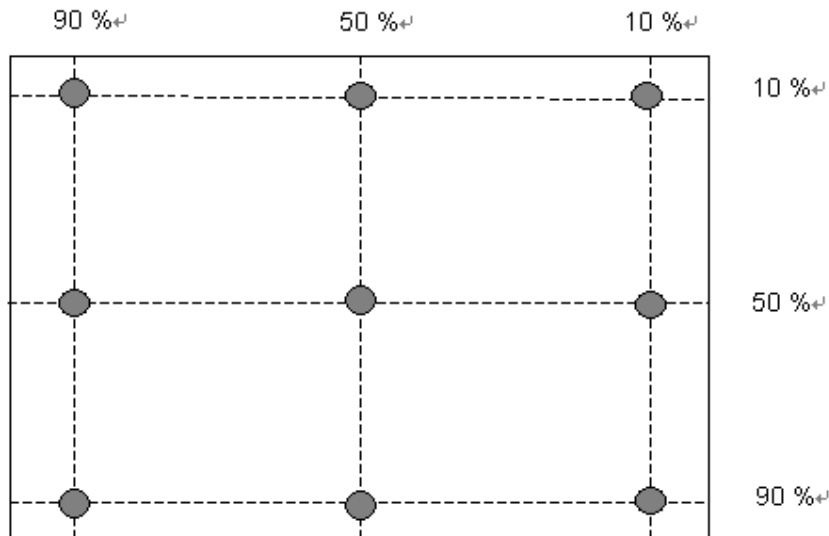

$$\text{Uniformity} = \frac{\text{Minimum Luminance in 9 points (1-9)}}{\text{Maximum Luminance in 9 Points (1-9)}}$$

Note 8: Crosstalk is defined as below and measured by TOPCON SR-3

$$CT = |YB - YA| / YA \times 100 (\%)$$

Where

YA = Luminance of measured location without gray level 0 pattern (cd/m²)

YB = Luminance of measured location with gray level 0 pattern (cd/m²)

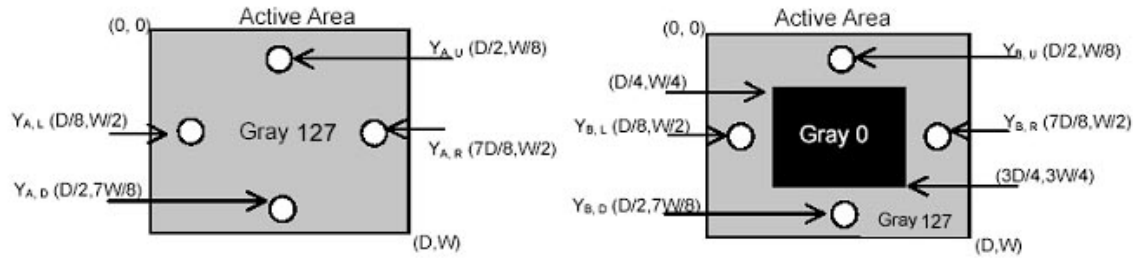

Note 9: Test Pattern: Subchecker Pattern measured by TOPCON SR-3

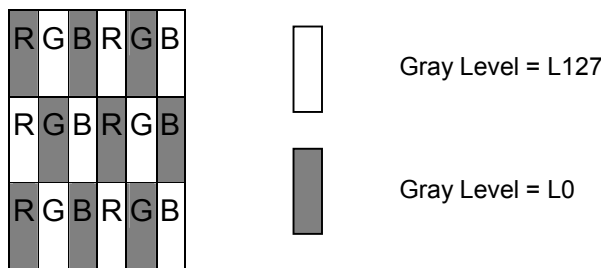

Method: Record dBV & DC value with TRD-100

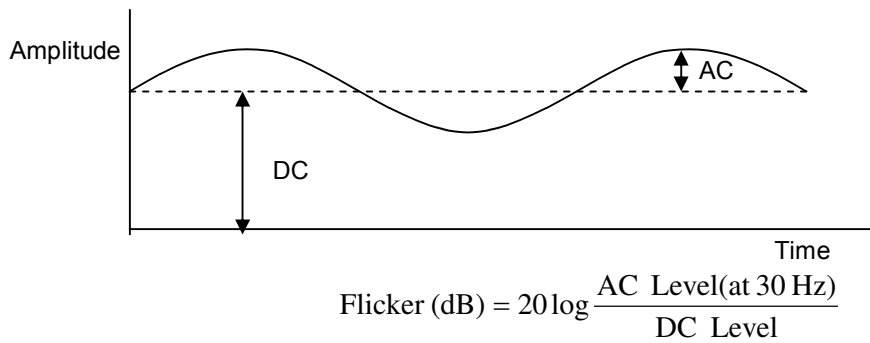

3.0 Functional Block Diagram

The following diagram shows the functional block of the 18.5 inch Color TFT-LCD Module:

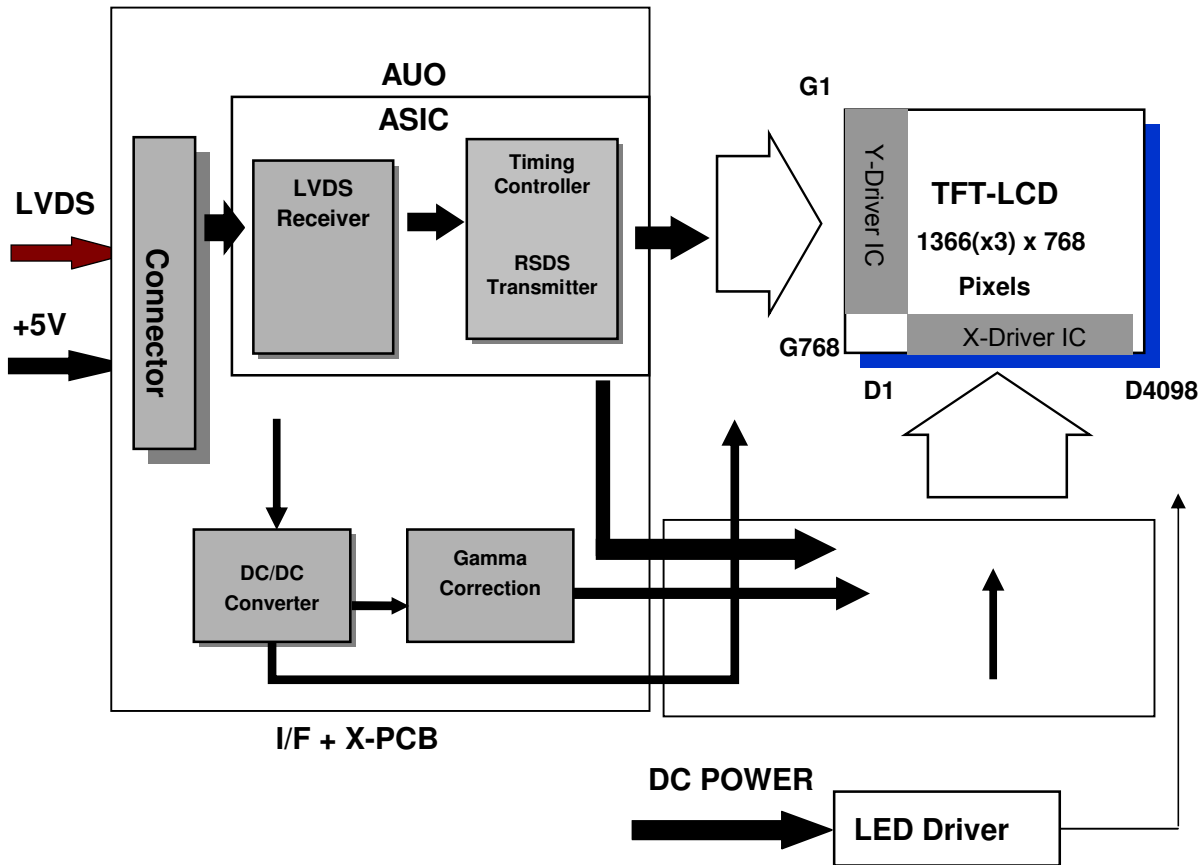

I/F PCB Interface:

187145-30091-3 (P-TWO)

Mating Type:

117 Series (P-TWO)

4.0 Absolute Maximum Ratings

Absolute maximum ratings of the module are as following:

4.1 TFT LCD Module

Item	Symbol	Min	Max	Unit	Conditions
Logic/LCD Drive Voltage	VDD	4.5	+5.5	[Volt]	<i>Note 1,2</i>

4.2 Absolute Ratings of Environment

Item	Symbol	Min.	Max.	Unit	Conditions
Operating Temperature	TOP	0	+60	[°C]	<i>Note 3 & 4</i>
Operation Humidity	HOP	5	90	[%RH]	
Storage Temperature	TST	-20	+60	[°C]	
Storage Humidity	HST	5	90	[%RH]	



Note 1: With in Ta (25°C)

Note 2: Permanent damage to the device may occur if exceeding maximum values

Note 3: For quality performance, please refer to AUO IIS(Incoming Inspection Standard).

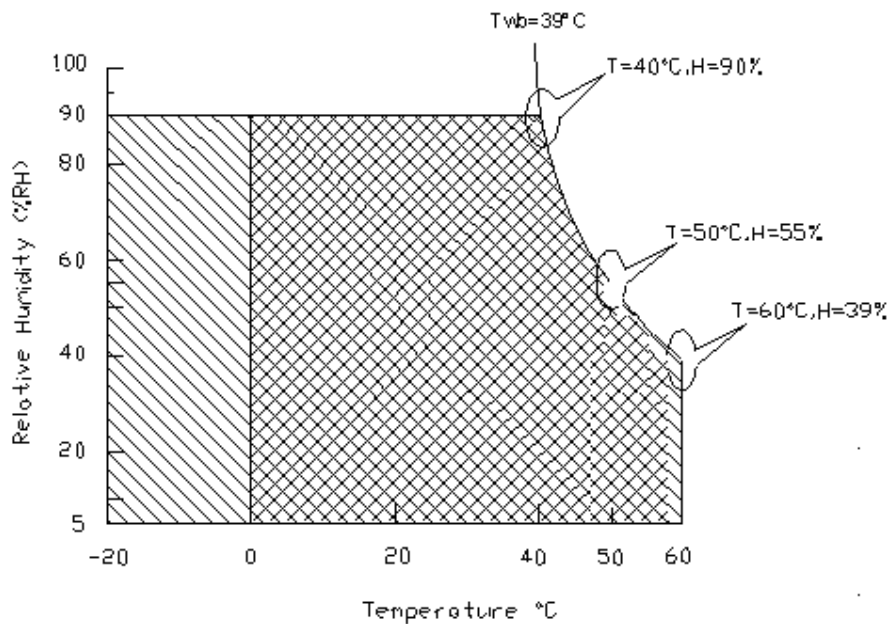
Note 4: Operation Temperature + 60°C is defined as panel surface temperature.



Operating Range  Storage Range  + 

5.0 Electrical characteristics

5.1 TFT LCD Module

5.1.1 Power Specification

Input power specifications are as follows:

Symbol	Parameter	Min	Typ	Max	Unit	Conditions
VDD	Logic/LCD Drive Voltage	4.5	5.0	5.5	[Volt]	+/-10%
IDD	Input Current	-	0.9	1.1	[A]	VDD= 5.0V, All Black Pattern At 60Hz,
PDD	VDD Power	-	4.5	5.5	[Watt]	VDD= 5.0V, All Black Pattern At 60Hz
IRush	Inrush Current	-	-	3	[A]	Note 1
VDDrp	Allowable Logic/LCD Drive Ripple Voltage	-	-	200	[mV] p-p	VDD= 5.0V, All Black Pattern At 60Hz

Note 1: Measurement conditions:

The duration of rising time of power input is 470us.

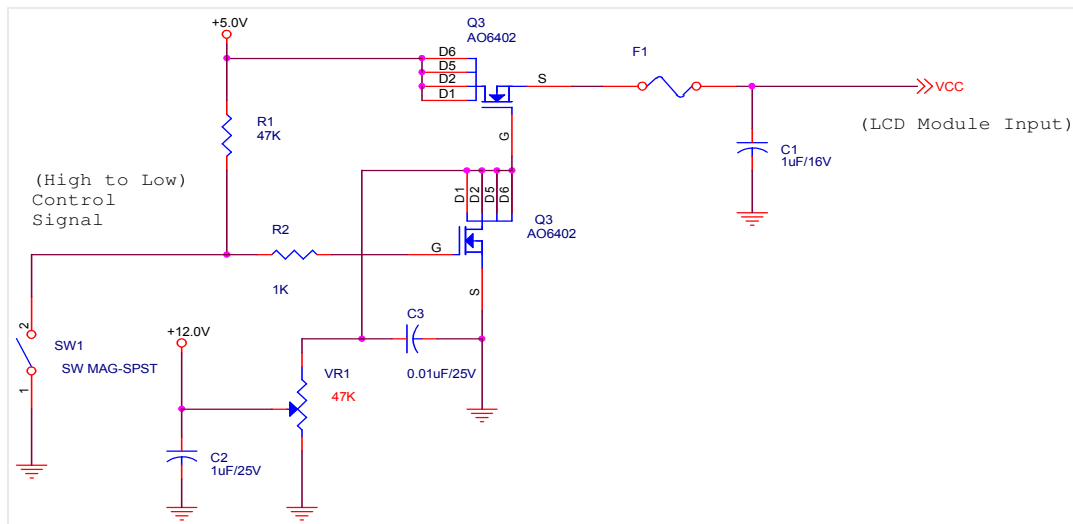

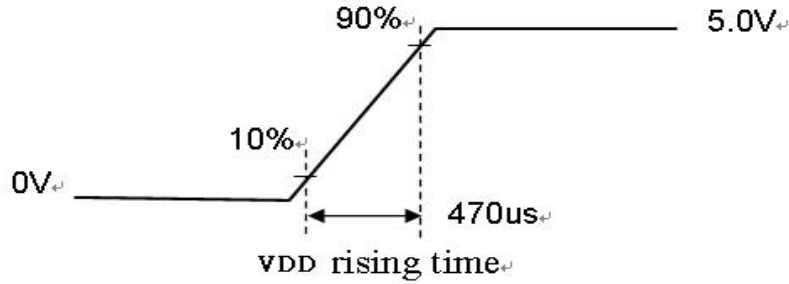

5.1.2 Signal Electrical Characteristics

Input signals shall be low or Hi-Z state when VDD is off. Please refer to specifications of SN75LVDS82DGG (Texas Instruments) in detail.

Characteristics of each signal are as follows:

Symbol	Parameter	Min	Typ	Max	Units	Condition
VTH	Differential Input High Threshold	-	+50	+100	[mV]	VICM = 1.2V Note 1
VTL	Differential Input Low Threshold	-100	-50	-	[mV]	VICM = 1.2V Note 1
VID	Input Differential Voltage	100	400	600	[mV]	Note 1
VICM	Differential Input Common Mode Voltage	+1.0	+1.2	+1.4	[V]	VTH-VTL = 200mV (max) Note 1

Note 1: LVDS Signal Waveform

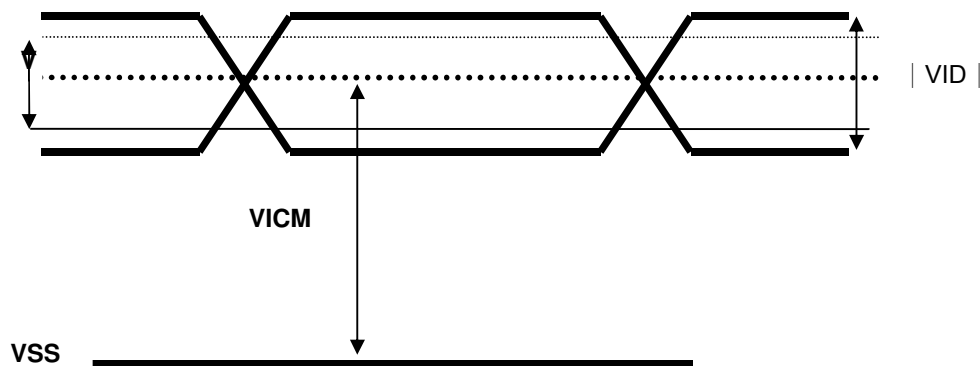

5.2 Backlight Unit

Following characteristics are measured under a stable condition at 25 °C (Room Temperature):

Symbol	Parameter	Min.	Typ.	Max.	Unit	Remark
VCC	Input Voltage	10.8	12	13.2	[Volt]	
I_{VCC}	Input Current		0.75	1	[A]	100% PWM Duty
P_{VCC}	Power Consumption		9	13.2	[Watt]	100% PWM Duty
I_{rush LED}	Inrush Current	-		3	[A]	at rising time=470us
V_{LED on/off}	On Control Voltage	3	5	5.5	Volt	
	Off Control Voltage			0.8	Volt	
F_{PWM}	Dimming Frequency	200	-	20k	[Hz]	
	Swing Voltage	3	3.3	5	V	
	High Voltage	3	3.3	5.5	Volt	
	Low Voltage			0.8	Volt	
	Dimming Duty Cycle	5	-	100	%	
I_F	LED Forward Current		50		mA	Ta = 25 °C
V_F	LED Forward Voltage	-	3.2	3.6	Volt	I _F 50mA, Ta = 25°C
P_{LED}	LED Power Consumption	-		0.18	Watt	I _F 50mA, Ta = 25°C
Operation Lifetime		50,000			Hrs	I _F 50mA, Ta= 25°C

Note 1: Ta means ambient temperature of TFT-LCD module.

Note 2: VCC, I_{VCC}, P_{VCC}, I_{rush LED} are defined for LED B/L.(100% duty of PWM dimming)

Note 3: I_F, V_F, P_{LED} are defined for single LED.

Note 4: If G185XW01 V2 module is driven by high current or at high ambient temperature & humidity condition. The operating life will be reduced.

Note 5: Operation life means brightness goes down to 50% initial brightness. Minimum operating life time is estimated data.

6.0 Signal Characteristic

6.1 Pixel Format Image

Following figure shows the relationship of the input signals and LCD pixel format.

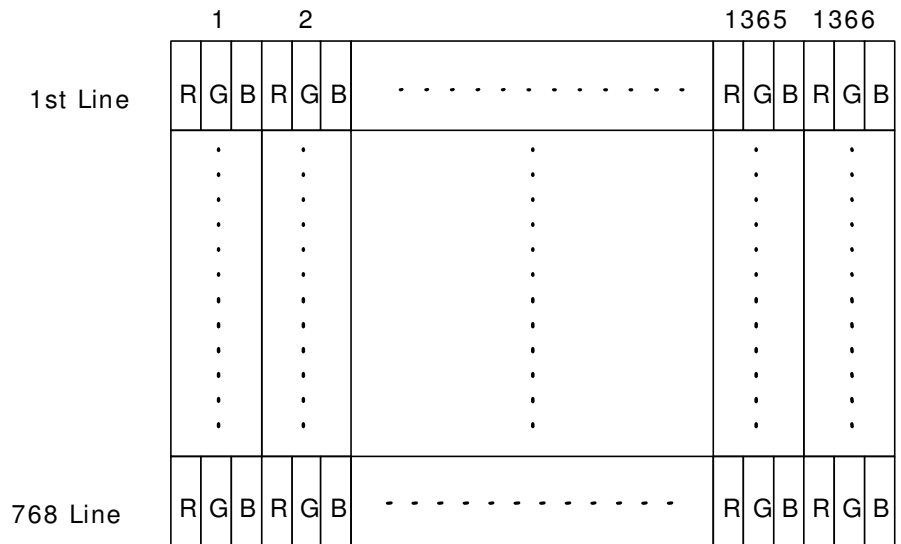

6.2 The input data format

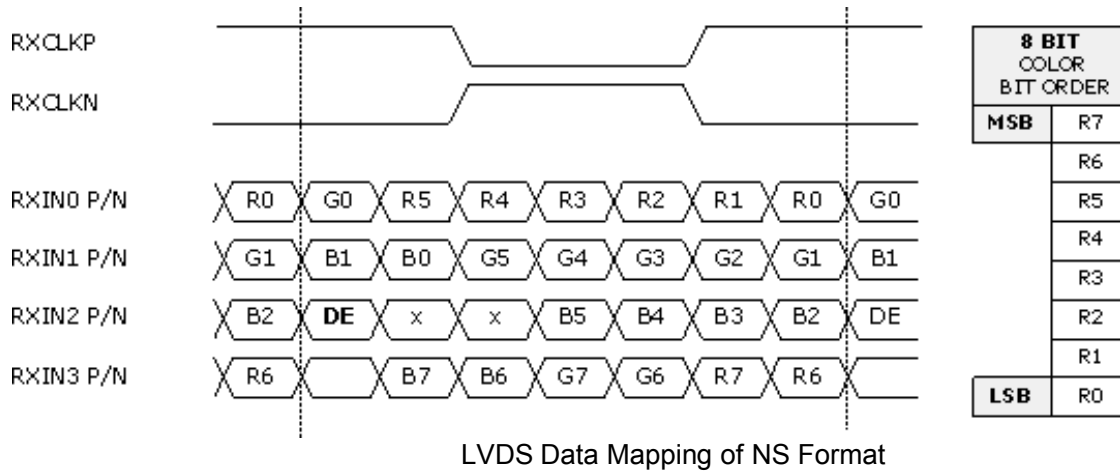

Note1: Normally, DE, VS, HS on EVEN channel are not used.

Note2: 8-bits signal input.

6.3 Signal Description

The module using one LVDS receiver SN75LVDS82(Texas Instruments). LVDS is a differential signal technology for LCD interface and high speed data transfer device. LVDS transmitters shall be SN75LVDS83(negative edge sampling). The first LVDS port(RxOxxx) transmits odd pixels while the second LVDS port(RxExxx) transmits even pixels.

PIN #	SIGNAL NAME	DESCRIPTION
1	NC	No contact (For AUO internal use)
2	NC	No contact (For AUO internal use)
3	NC	No contact (For AUO internal use)
4	GND	Power Ground
5	RXIN0-	Negative LVDS differential data input (0)
6	RXIN0+	Positive LVDS differential data input (0)
7	GND	Power Ground
8	RXIN1-	Negative LVDS differential data input (1)
9	RXIN1+	Positive LVDS differential data input (1)
10	GND	Power Ground
11	RXIN2-	Negative LVDS differential data input (2)
12	RXIN2+	Positive LVDS differential data input (2)
13	GND	Power Ground
14	RXCLKIN-	Negative LVDS differential clock input (clock)
15	RXCLKIN+	Positive LVDS differential data input (clock)
16	GND	Power Ground
17	RXIN3-	Negative LVDS differential data input (3)
18	RXIN3+	Positive LVDS differential data input (3)
19	GND	Power Ground
20	NC	No contact (For AUO internal use)
21	NC	No contact (For AUO internal use)
22	NC	No contact (For AUO internal use)
23	GND	Power Ground
24	GND	Power Ground
25	GND	Power Ground
26	VDD	+5V power supply
27	VDD	+5V power supply
28	VDD	+5V power supply
29	VDD	+5V power supply
30	VDD	+5V power supply

Note1: Start from left side

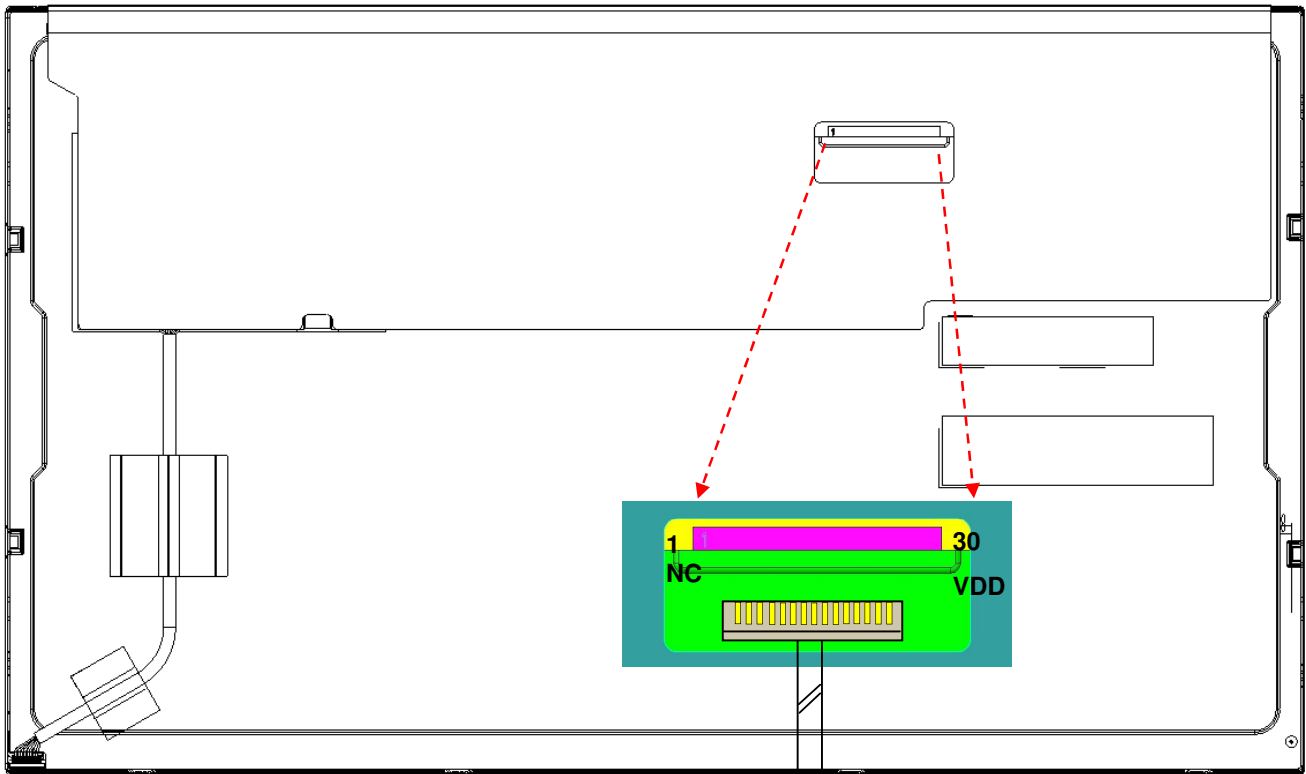

Note2: Input signals of clock shall be the same timing.

Note3: Please follow TV VESA Pin Assignment.

6.4 Timing Characteristics

Basically, interface timing described here is not actual input timing of LCD module but close to output timing of SN75LVDS82DGG (Texas Instruments) or equivalent.

Signal	Item	Symbol	Min	Typ	Max	Unit
V-section	Period	T _v	776	808	1023	Th
	Active	T _{disp(v)}	768	768	768	Th
	Blanking	T _{blk(v)}	8	40	255	Th
H-section	Period	T _h	1416	1606	2047	T _{clk}
	Active	T _{disp(h)}	1366	1366	1366	T _{clk}
	Blanking	T _{blk(h)}	50	240	681	T _{clk}
Clock	Period	T _{clk}	-	12.8	-	ns
	Frequency	F _{req}	-	78	90	MHz
Frame Rate	Frame Rate	F	50	60	75	Hz

Note1 : DE mode only

Note2 : Clock Frequency 90MHz(Max.)= 1416(H)*847(V)*75Hz

6.5 Timing diagram

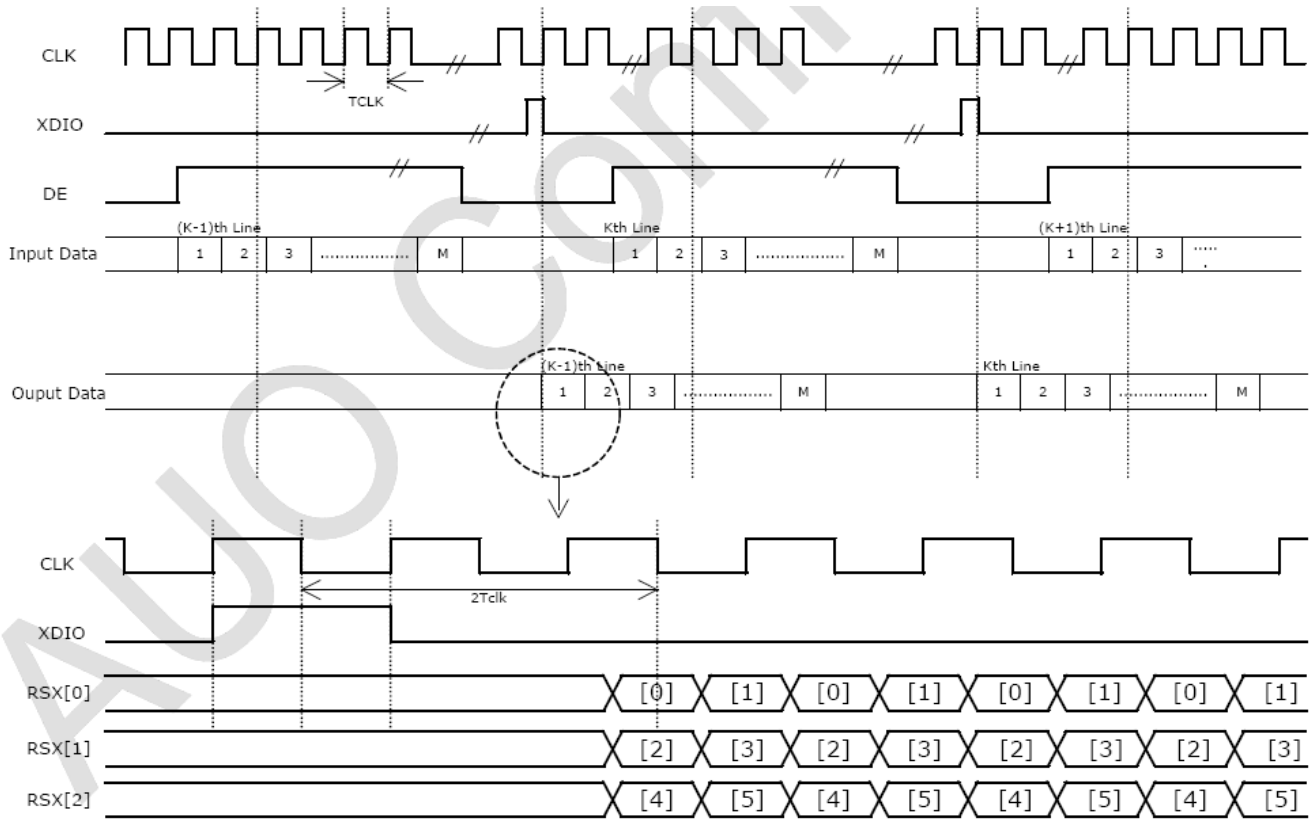

6.6 Power ON/OFF Sequence

VDD power and LED on/off sequence are as follows. Interface signals are also shown in the chart. Signals from any system shall be Hi-Z state or low level when VDD is off.

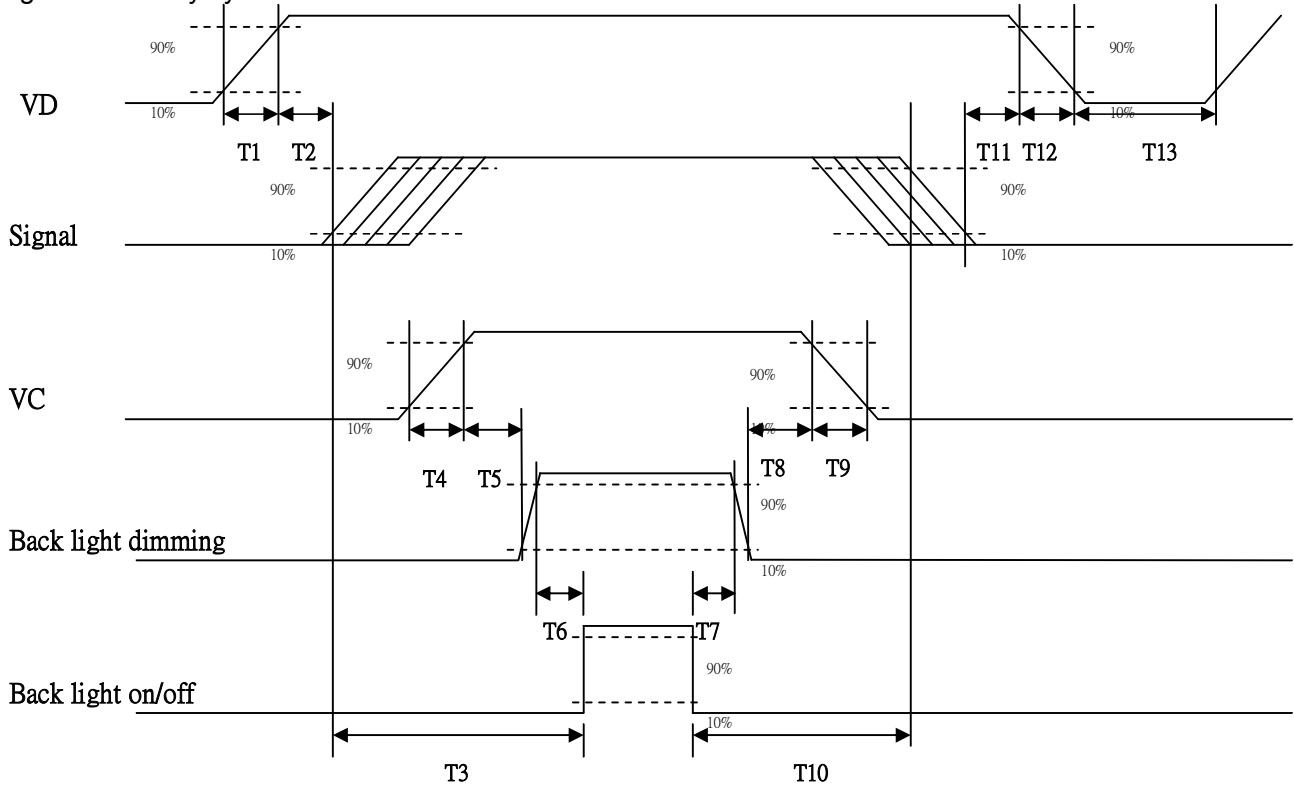

Power ON/OFF sequence timing

Parameter	Value			Units
	Min.	Typ.	Max.	
T1	0.5	-	10	[ms]
T2	0	40	50	[ms]
T3	200	-	-	[ms]
T4	0.5	-	10	[ms]
T5	10	-	-	[ms]
T6	10	-	-	[ms]
T7	0	-	-	[ms]
T8	10	-	-	[ms]
T9	-	-	10	[ms]
T10	110	-	-	[ms]
T11	0.5	16	50	[ms]
T12	-	-	100	[ms]
T13	1000	-	-	[ms]

7.0 Connector & Pin Assignment

Physical interface is described as for the connector on module. These connectors are capable of accommodating the following signals and will be following components.

7.1 TFT LCD Module

Connector Name / Designation	Interface Connector / Interface card
Manufacturer	P-TWO
Type Part Number	187145-30091-3
Mating Housing Part Number	117 Series

7.1.1 Pin Assignment

Pin#	Signal Name	Pin#	Signal Name
1	NC	2	NC
3	NC	4	GND
5	RXIN0-	6	RXIN0+
7	GND	8	RXIN1-
9	RXIN1+	10	GND
11	RXIN2-	12	RXIN2+
13	GND	14	RXCLKIN-
15	RXCLKIN+	16	GND
17	RXIN3-	18	RXIN3+
19	GND	20	NC
21	NC	22	NC
23	GND	24	GND
25	GND	26	VDD
27	VDD	28	VDD
29	VDD	30	VDD

7.2 LED Backlight Unit: LED Driver Connector

Connector Name / Designation	LED Connector
Manufacturer	E&T or compatible
Connector Model Number	3808K-F05N-12R or compatible
Mating Connector Model Number	H208K-P05N-02B or compatible



7.3 LED Driver Connector Pin Assignment

Pin#	Symbol	Signal Name
1	VCC	12V
2	GND	GND
3	Enable	5V-On / 0V-Off
4	Dimming	PWM Dimming
5	NC	NC

8.0 Reliability Test

Environment test conditions are listed as following table.

Items	Required Condition	Note
Temperature Humidity Bias (THB)	Ta= 50°C, 80%RH, 300hours	
High Temperature Operation (HTO)	Tgs= 60°C, 300hours, For panel surface temp.	3&4
Low Temperature Operation (LTO)	Ta= 0°C, 300hours	
High Temperature Storage (HTS)	Ta= 60°C, 300hours	
Low Temperature Storage (LTS)	Ta= -20°C, 300hours	
Vibration Test (Non-operation)	Acceleration: 1.5 Grms Wave: Random Frequency: 10 - 200 Hz Sweep: 30 Minutes each Axis (X, Y, Z)	
Shock Test (Non-operation)	Acceleration: 50 G Wave: Half-sine Active Time: 20 ms Direction: ±X, ±Y, ±Z (one time for each Axis)	
Drop Test	Height: 60 cm, package test	
Thermal Shock Test (TST)	-20°C /30min, 60°C /30min, 100 cycles	1
On/Off Test	On/10sec, Off/10sec, 30,000 cycles	
ESD (Electro Static Discharge)	Contact Discharge: ± 8KV, 150pF(330Ω) 1sec, 8 points, 25 times/ point.	2
	Air Discharge: ± 15KV, 150pF(330Ω) 1sec 8 points, 25 times/ point.	
Altitude Test	Operation:10,000 ft Non-Operation:30,000 ft	

Note 1: The TFT-LCD module will not sustain damage after being subjected to 100 cycles of rapid temperature change. A cycle of rapid temperature change consists of varying the temperature from -20°C to 60°C, and back again. Power is not applied during the test. After temperature cycling, the unit is placed in normal room ambient for at least 4 hours before power on.

Note 2: According to EN61000-4-2 , ESD class B: Some performance degradation allowed. No data lost. Self-recoverable. No hardware failures.

Note 3: Tgs = Panel surface temperature

Note 4: No function occurs Mura shall be ignored after high temperature reliability test.

9.0 Shipping Label & Packaging

9.1 Shipping Label

The label is on the panel as shown below:



Note 1: For Pb Free products, AUO will add  for identification.

Note 2: For RoHS compatible products, AUO will add  for identification.

Note 3: For China RoHS compatible products, AUO will add  for identification.

Note 4: The Green Mark will be presented only when the green documents have been ready by AUO Internal Green Team.

9.2 Packaging

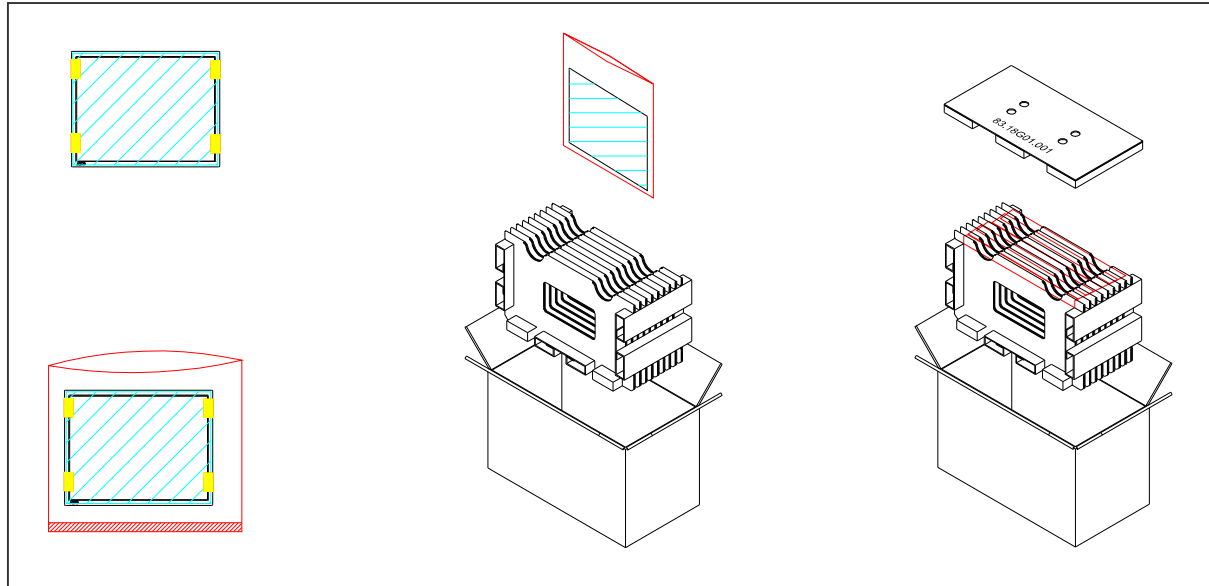

Max capacity : 8 TFT-LCD module per carton

Max weight: 15.0 kg per carton

Outside dimension of carton: 520mm(L)* 280mm(W)*352mm(H)

Pallet size : 1140 mm *1060 mm * 135mm

Box stacked

By air_max : (2 *4) *4 layers , one pallet put 32 boxes , total 256pcs module

By sea_max : (2 *4) *4 layers + (2 *4) *1 layers , two pallet put 40 boxes , total 320pcs module

By sea_HQ_max : (2 *4) *4 layers+(2 *4) *2 layers, two pallet put 48 boxes, total 384pcs module

9.3 Palletizing

	MAX SHIPPING BY AIR	MAX SHIPPING BY SEA	MAX SHIPPING BY SEA_HQ
MODULE/CARTON	8	8	8
CARTON/LAYER	8	8	8
LAYER/PALLET	4	4+1	4+2
MODULE/PALLET	256	320	384
CARTON SIZE(MM)	520(L)*280(W)*352(H)	520(L)*280(W)*352(H)	520(L)*280(W)*352(H)
PALLET SIZE(MM)	1140(L)*1060(W)*140(H)	1140(L)*1060(W)*140(H)	1140(L)*1060(W)*140(H)
TOTAL PALLET HEIGHT(MM)	1548	2040	2392
TOTAL PALLET WEIGHT(KG)	493	626	746

ONE PALLET SHIPMENT EXAMPLE SHIPPING BY AIR USED

TWO PALLET SHIPMENT EXAMPLE SHIPPING BY SEA USED

TWO PALLET SHIPMENT EXAMPLE SHIPPING BY SEA_HQ USED

STRETCH FILM

PALLET

CORNER ANGLE

PET BAND

Copyright © 2014 AU Optronics Corporation. All Rights Reserved. This document is the property of AU Optronics Corporation. No part of this document may be reproduced without the prior written permission of AU Optronics Corporation.

DATE	2014.08.01	DESCRIPTION	PACKAGE DRAWING
REV	01	REVISED BY	WJ
REV	02	REVISED BY	WJ
REV	03	REVISED BY	WJ
REV	04	REVISED BY	WJ
REV	05	REVISED BY	WJ
REV	06	REVISED BY	WJ
REV	07	REVISED BY	WJ
REV	08	REVISED BY	WJ
REV	09	REVISED BY	WJ
REV	10	REVISED BY	WJ
REV	11	REVISED BY	WJ
REV	12	REVISED BY	WJ
REV	13	REVISED BY	WJ
REV	14	REVISED BY	WJ
REV	15	REVISED BY	WJ
REV	16	REVISED BY	WJ
REV	17	REVISED BY	WJ
REV	18	REVISED BY	WJ
REV	19	REVISED BY	WJ
REV	20	REVISED BY	WJ
REV	21	REVISED BY	WJ
REV	22	REVISED BY	WJ
REV	23	REVISED BY	WJ
REV	24	REVISED BY	WJ
REV	25	REVISED BY	WJ
REV	26	REVISED BY	WJ
REV	27	REVISED BY	WJ
REV	28	REVISED BY	WJ
REV	29	REVISED BY	WJ
REV	30	REVISED BY	WJ
REV	31	REVISED BY	WJ
REV	32	REVISED BY	WJ
REV	33	REVISED BY	WJ
REV	34	REVISED BY	WJ
REV	35	REVISED BY	WJ
REV	36	REVISED BY	WJ
REV	37	REVISED BY	WJ
REV	38	REVISED BY	WJ
REV	39	REVISED BY	WJ
REV	40	REVISED BY	WJ
REV	41	REVISED BY	WJ
REV	42	REVISED BY	WJ
REV	43	REVISED BY	WJ
REV	44	REVISED BY	WJ
REV	45	REVISED BY	WJ
REV	46	REVISED BY	WJ
REV	47	REVISED BY	WJ
REV	48	REVISED BY	WJ
REV	49	REVISED BY	WJ
REV	50	REVISED BY	WJ
REV	51	REVISED BY	WJ
REV	52	REVISED BY	WJ
REV	53	REVISED BY	WJ
REV	54	REVISED BY	WJ
REV	55	REVISED BY	WJ
REV	56	REVISED BY	WJ
REV	57	REVISED BY	WJ
REV	58	REVISED BY	WJ
REV	59	REVISED BY	WJ
REV	60	REVISED BY	WJ
REV	61	REVISED BY	WJ
REV	62	REVISED BY	WJ
REV	63	REVISED BY	WJ
REV	64	REVISED BY	WJ
REV	65	REVISED BY	WJ
REV	66	REVISED BY	WJ
REV	67	REVISED BY	WJ
REV	68	REVISED BY	WJ
REV	69	REVISED BY	WJ
REV	70	REVISED BY	WJ
REV	71	REVISED BY	WJ
REV	72	REVISED BY	WJ
REV	73	REVISED BY	WJ
REV	74	REVISED BY	WJ
REV	75	REVISED BY	WJ
REV	76	REVISED BY	WJ
REV	77	REVISED BY	WJ
REV	78	REVISED BY	WJ
REV	79	REVISED BY	WJ
REV	80	REVISED BY	WJ
REV	81	REVISED BY	WJ
REV	82	REVISED BY	WJ
REV	83	REVISED BY	WJ
REV	84	REVISED BY	WJ
REV	85	REVISED BY	WJ
REV	86	REVISED BY	WJ
REV	87	REVISED BY	WJ
REV	88	REVISED BY	WJ
REV	89	REVISED BY	WJ
REV	90	REVISED BY	WJ
REV	91	REVISED BY	WJ
REV	92	REVISED BY	WJ
REV	93	REVISED BY	WJ
REV	94	REVISED BY	WJ
REV	95	REVISED BY	WJ
REV	96	REVISED BY	WJ
REV	97	REVISED BY	WJ
REV	98	REVISED BY	WJ
REV	99	REVISED BY	WJ
REV	100	REVISED BY	WJ



10.0 Mechanical Characteristics

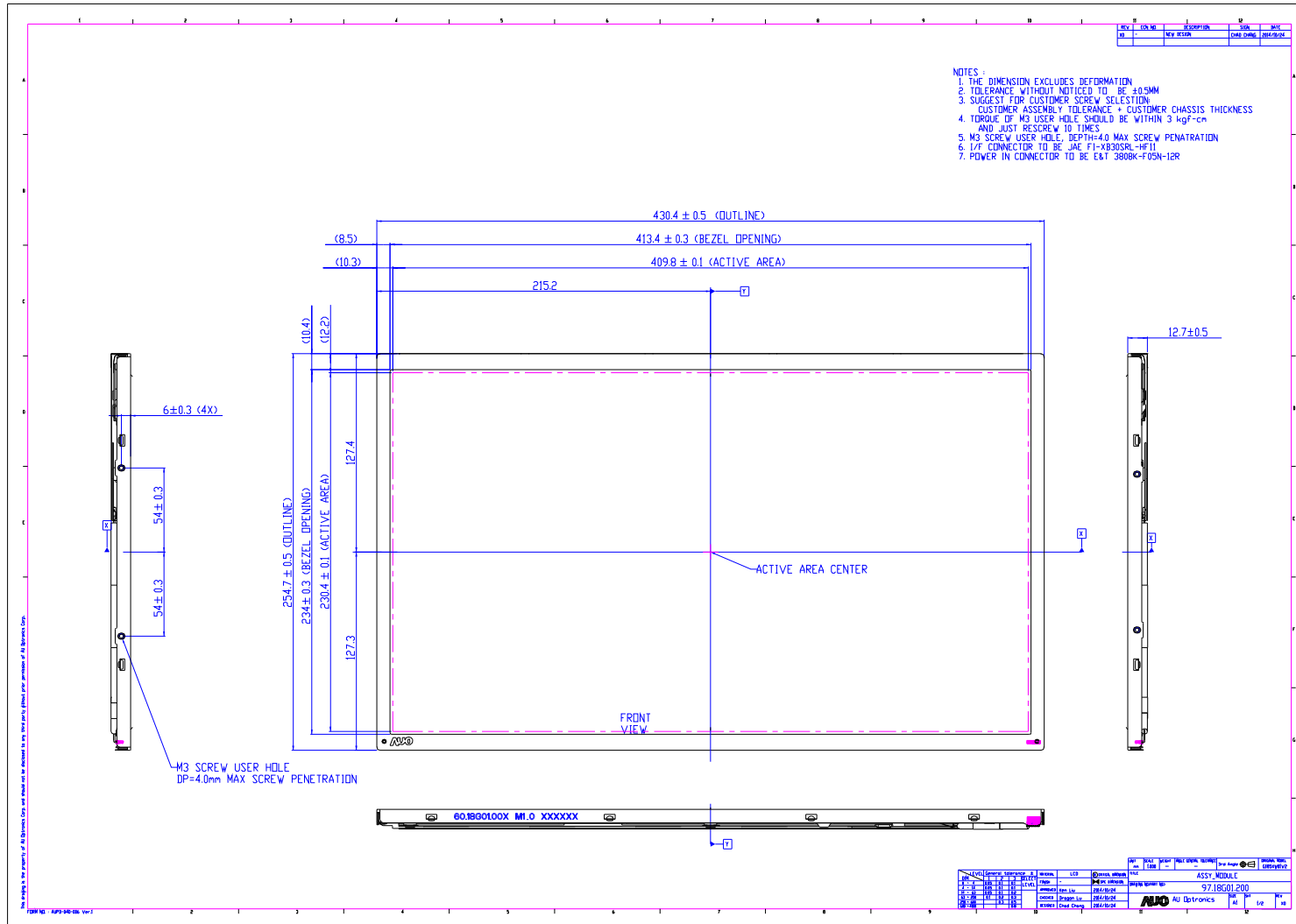



Product Specification

AU OPTRONICS CORPORATION

G185XW01 V2

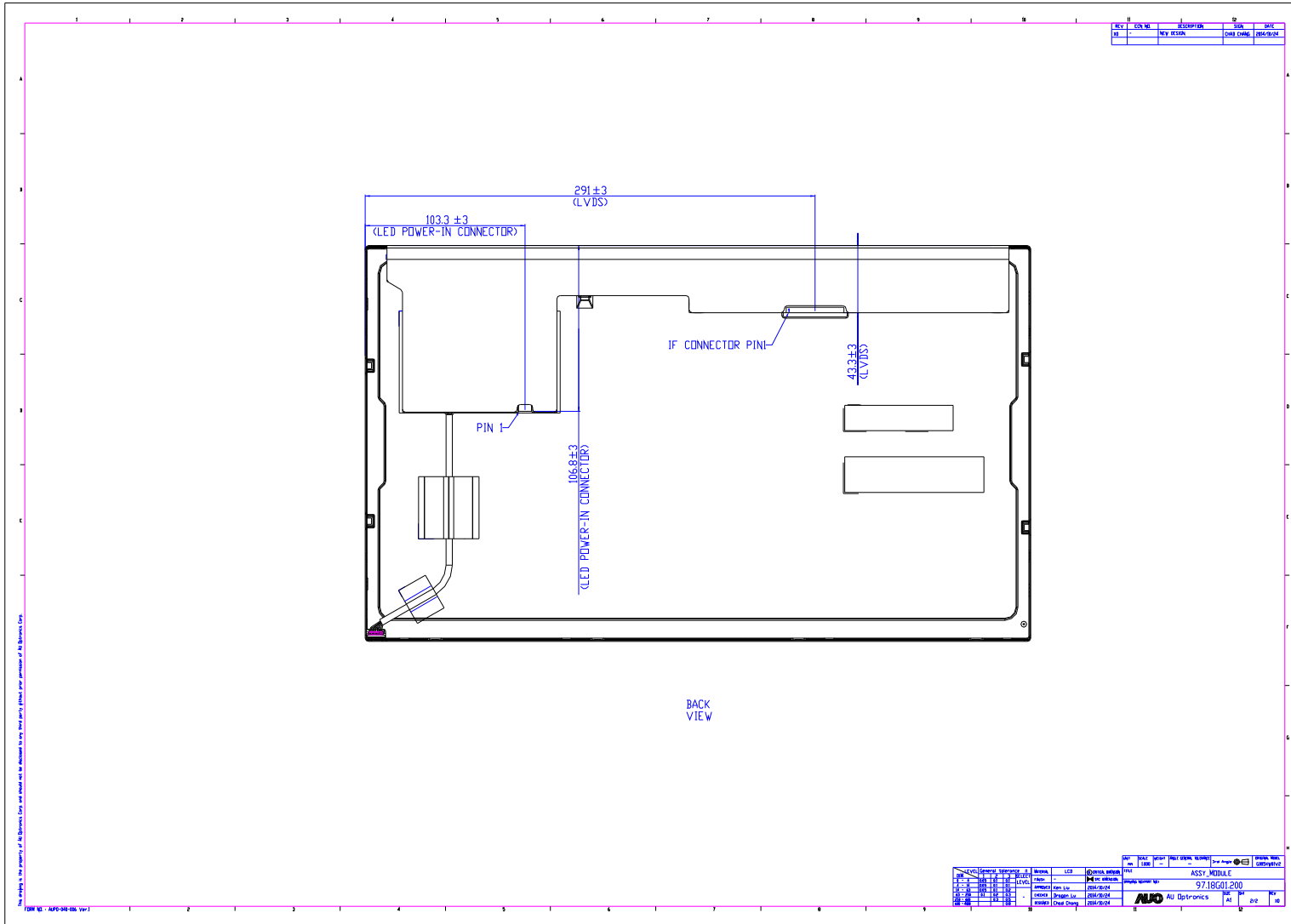

11 Safety

11.1 Sharp Edge Requirements

There will be no sharp edges or comers on the display assembly that could cause injury.

11.2 Materials

11.2.1 Toxicity

There will be no carcinogenic materials used anywhere in the display module. If toxic materials are used, they will be reviewed and approved by the responsible AUO toxicologist.

11.2.2 Flammability

All components including electrical components that do not meet the flammability grade UL94-V1 in the module will complete the flammability rating exception approval process.

The printed circuit board will be made from material rated 94-V1 or better. The actual UL flammability rating will be printed on the printed circuit board.

11.3 Capacitors

If any polarized capacitors are used in the display assembly, provisions will be made to keep them from being inserted backwards.

11.4 National Test Lab Requirement

The display module will satisfy all requirements for compliance to:

UL 60950-1, Second Edition

U.S.A. Information Technology Equipment