

TFT-DISPLAY DATASHEET

AUO
Model: G150XTN03.6

BRIEF SPEC.:

| | |
|-----------------------|---------------------------------------|
| Main Feature | Landscape Type White LED Backlight |
| Active Screen Area | 304.12 x 228.09 (mm) |
| Diagonal Format | 15.0" 4:3 |
| Resolution | 1024 X 768 |
| Colors | 262k16.7M (6 Bit) |
| Backlight | LED |
| Brightness | 250 cd/m ² |
| LED Life Time | 50K (h) |
| Interface | LVDS |
| Viewing Angle | 45/45 L/R 20/40 |
| Touchscreen | No |
| Power Supply | 3.3 V (Typ.) |
| Module Outline | 326.5 x 253.5 x 10.0 (mm) |
| Operation Temperature | 0... +65 °C |
| Storage Temperature | -20... +65 °C |
| Surface Treatment | Anti-Glare, Hardness 3H |

Contents

| | |
|---|-----------|
| 1. Operating Precautions | 4 |
| 2. General Description | 5 |
| 2.1 Display Characteristics | 5 |
| 2.2 Optical Characteristics | 6 |
| 3. Functional Block Diagram | 9 |
| 4. Absolute Maximum Ratings..... | 10 |
| 4.1 Absolute Ratings of TFT LCD Module..... | 10 |
| 4.2 Absolute Ratings of Environment..... | 10 |
| 5.1 TFT LCD Module | 11 |
| 5.2 Backlight Unit..... | 13 |
| 6. Signal Characteristic..... | 14 |
| 6.1 Pixel Format Image..... | 14 |
| 6.2 Scanning Direction..... | 14 |
| 6.3 Signal Description | 15 |
| 6.4 The Input Data Format..... | 16 |
| 6.5 Interface Timing | 17 |
| 6.6 Power ON/OFF Sequence | 18 |
| 7. Connector & Pin Assignment | 19 |
| 7.1 TFT LCD Module: LVDS Connector..... | 19 |
| 7.2 LED Backlight Unit: LED Driver Connector | 20 |
| 7.2 LED Backlight Unit: LED Driver Connector | 21 |
| 7.3 LED Driver Connector Pin Assignment | 21 |
| 8. Reliability Test Criteria..... | 22 |
| 9. Mechanical Characteristics | 23 |
| 9.1 LCM Outline Dimension (Front View)..... | 23 |
| 9.2 CM Outline Dimension (Rear View) | 24 |
| 10. Label and Packaging | 25 |
| 10.1 Shipping Label (on the rear side of TFT-LCD display) | 25 |
| 10.2 Carton Package | 25 |
| 10.3 Palletizing..... | 26 |
| 11 Safety..... | 27 |
| 11.1 Sharp Edge Requirements | 27 |
| 11.2 Materials..... | 27 |
| 11.3 Capacitors | 27 |
| 11.4 National Test Lab Requirement..... | 27 |





Record of Revision

| Version and Date | Page | Old description | New Description |
|------------------|------|-----------------|-----------------|
| 0.0 2016/8/15 | All | First Edition | |
| | | | |
| | | | |
| | | | |
| | | | |
| | | | |
| | | | |
| | | | |



1. Operating Precautions

- 1) Since front polarizer is easily damaged, please be cautious and not to scratch it.
- 2) Be sure to turn off power supply when inserting or disconnecting from input connector.
- 3) Wipe off water drop immediately. Long contact with water may cause discoloration or spots.
- 4) When the panel surface is soiled, wipe it with absorbent cotton or soft cloth.
- 5) Since the panel is made of glass, it may be broken or cracked if dropped or bumped on hard surface.
- 6) Since CMOS LSI is used in this module, take care of static electricity and insure human earth when handling.
- 7) Do not open nor modify the module assembly.
- 8) Do not press the reflector sheet at the back of the module to any direction.
- 9) In case if a module has to be put back into the packing container slot after it was taken out from the container, do not press the center of the LED Reflector edge. Instead, press at the far ends of the LED Reflector edge softly. Otherwise the TFT Module may be damaged.
- 10) At the insertion or removal of the Signal Interface Connector, be sure not to rotate nor tilt the Interface Connector of the TFT Module.
- 11) TFT-LCD Module is not allowed to be twisted & bent even force is added on module in a very short time. Please design your display product well to avoid external force applying to module by end-user directly.
- 12) Small amount of materials without flammability grade are used in the TFT-LCD module. The TFT-LCD module should be supplied by power complied with requirements of Limited Power Source (IEC60950-1 or UL60950-1), or be applied exemption.
- 13) Severe temperature condition may result in different luminance, response time.
- 14) Continuous operating TFT-LCD Module under high temperature environment may accelerate LED light bar exhaustion and reduce luminance dramatically.
- 15) The data on this specification sheet is applicable when TFT-LCD module is placed in landscape position.
- 16) Continuous displaying fixed pattern may induce image sticking. It's recommended to use screen saver or moving content periodically if fixed pattern is displayed on the screen.



2. General Description

G150XTN03.6 is a Color Active Matrix Liquid Crystal Display composed of a TFT-LCD display, a driver circuit, and a backlight system. The screen format is intended to support XGA (1024(H) x 768(V)) screen and 262K / 16.2M (RGB 6/8-bits) colors. All input signals are LVDS interface compatible.

G150XTN03.6 is designed for industrial display applications.

2.1 Display Characteristics

The following items are characteristics summary on the table under 25 °C condition:

| Items | Unit | Specifications |
|---|--------------|--|
| Screen Diagonal | [inch] | 15 |
| Active Area | [mm] | 304.128(H) x 228.096(V) |
| Pixels H x V | | 1024x3(RGB) x 768 |
| Pixel Pitch | [mm] | 0.297 x 0.297 |
| Pixel Arrangement | | R.G.B. Vertical Stripe |
| Display Mode | | TN, Normally White |
| Nominal Input Voltage VDD | [Volt] | 3.3 typ. |
| Typical Power Consumption | [Watt] | 7.1 W (Typ.), (all black pattern) |
| Weight | [Grams] | 1100g (max.) |
| Physical Size | [mm] | 326.5(H) x 253.5(V) x 10 (D) |
| Electrical Interface | | 1 channel LVDS |
| Surface Treatment | | Anti-glare, Hardness 3H |
| Support Color | | 16.2M / 262K colors |
| Temperature Range Operating Storage (Non-Operating) | [°C] [°C] | 0 to +65 (+65 °C as panel surface temperature) -20 to +65 |
| RoHS Compliance | | RoHS Compliance |
| Light Bar Unit | | LED, Non-Replaceable |



2.2 Optical Characteristics

The optical characteristics are measured under stable conditions at 25°C (Room Temperature):

| Item | Unit | Conditions | Min. | Typ. | Max. | Note |
|---|----------------------|---|----------|----------|--------|---------|
| White Luminance | [cd/m ²] | | 200 | 250 | - | 1 |
| Uniformity | % | 9 Points | 75 | 80 | - | 1, 2, 3 |
| Contrast Ratio | | | 400 | 500 | - | 4 |
| Cross talk | % | | - | -- | 1.5 | 5 |
| Response Time | [msec] | Rising | - | 5.7 | | 6 |
| | [msec] | Falling | - | 2.3 | | |
| | [msec] | Raising + Falling | - | 8 | | |
| Viewing Angle | [degree] [degree] | Horizontal (Right) (Left) CR = 10 | 35 35 | 45 45 | - - | 7 |
| | [degree] [degree] | Vertical (Upper) (Lower) CR = 10 | 15 30 | 20 40 | - - | |
| Color / Chromaticity Coordinates (CIE 1931) | | Red x | 0.543 | 0.593 | 0.643 | |
| | | Red y | 0.287 | 0.337 | 0.387 | |
| | | Green x | 0.275 | 0.325 | 0.375 | |
| | | Green y | 0.541 | 0.591 | 0.641 | |
| | | Blue x | 0.104 | 0.154 | 0.204 | |
| | | Blue y | 0.103 | 0.153 | 0.203 | |
| | | White x | 0.263 | 0.313 | 0.363 | |
| | | White y | 0.279 | 0.329 | 0.379 | |
| Color Gamut | % | | | 60 | - | |

Note 1: Measurement method

Equipment Pattern Generator, Power Supply, Digital Voltmeter, Luminance meter (SR_3 or equivalent)

Aperture 1" with 50cm viewing distance

Test Point Center

Environment < 1 lux

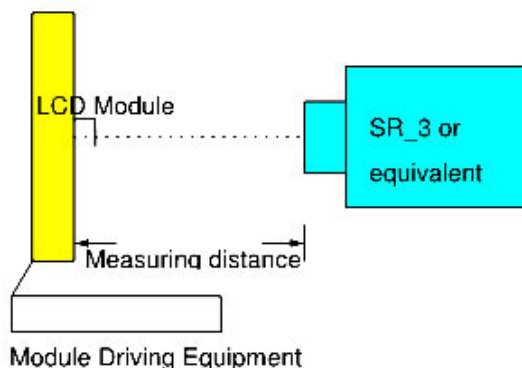

Note 2: Definition of 9 points position (Display active area: 304.128(H) x 228.096(V))

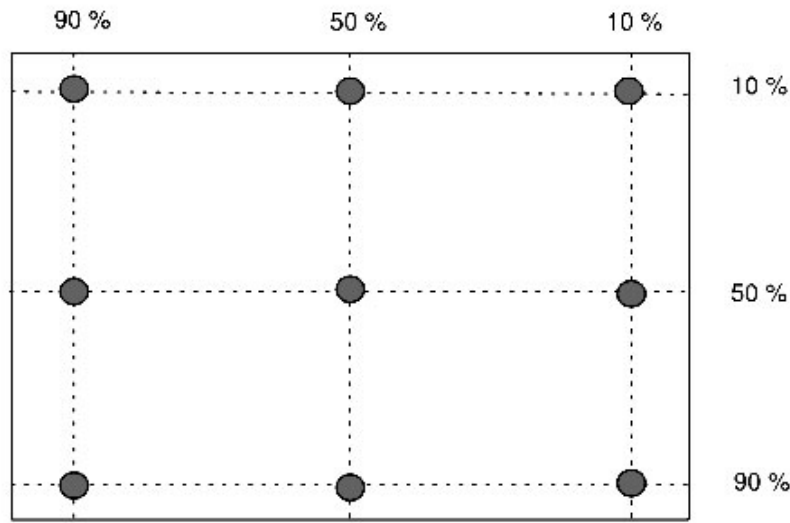

Note 3: The luminance uniformity of 9 points is defined by dividing the minimum luminance values by the maximum test point luminance

$$\bar{u}_{w9} = \frac{\text{Minimum Brightness of nine points}}{\text{Maximum Brightness of nine points}}$$

Note 4 : Definition of contrast ratio (CR):

$$\text{Contrast ratio (CR)} = \frac{\text{Brightness on the "White" state}}{\text{Brightness on the "Black" state}}$$

Note 5 : Definition of cross talk (CT)

$$CT = |YB - YA| / YA \times 100 (\%)$$

Where

YA = Luminance of measured location without gray level 0 pattern (cd/m²)

YB = Luminance of measured location with gray level 0 pattern (cd/m²)

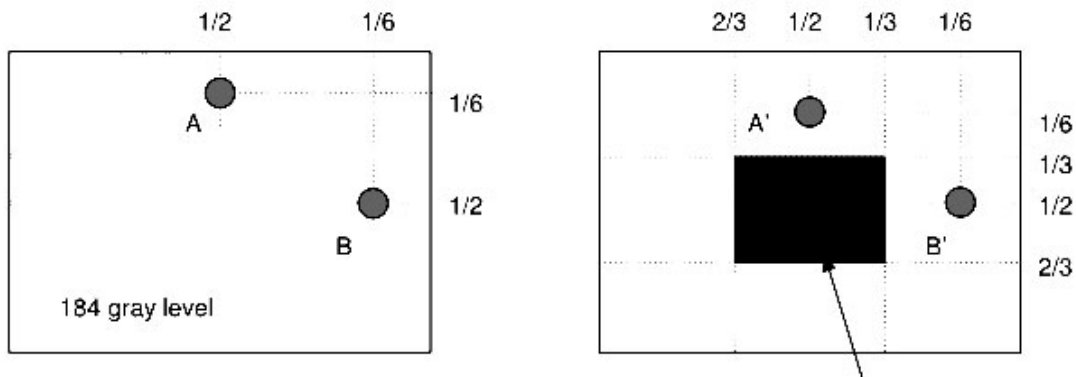

Note 6: Definition of response time:

The output signals of photo detector are measured when the input signals are changed from "White" to "Black" (falling time) and from "Black" to "White" (rising time), respectively. The response time interval is between 10% and 90% of amplitudes. Please refer to the figure as below.

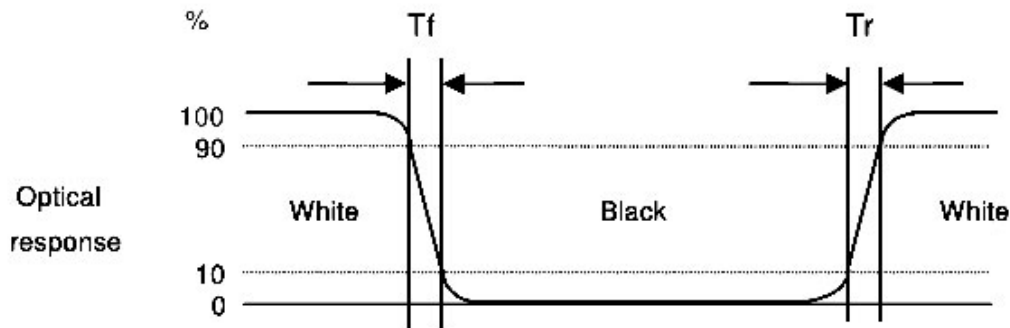

Note 7: Definition of viewing angle

Viewing angle is the measurement of contrast ratio ≥ 10 , at the screen center, over a 180° horizontal and 180° vertical range (off-normal viewing angles). The 180° viewing angle range is broken down as below: 90° (θ) horizontal left and right, and 90° (Φ) vertical high (up) and low (down). The measurement direction is typically perpendicular to the display surface with the screen rotated to its center to develop the desired measurement viewing angle.

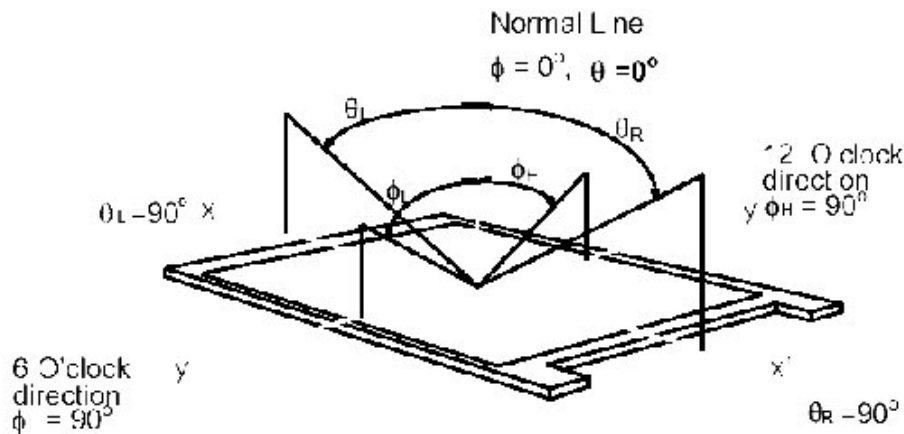

3. Functional Block Diagram

The following diagram shows the functional block of the 15 inch color TFT/LCD module:

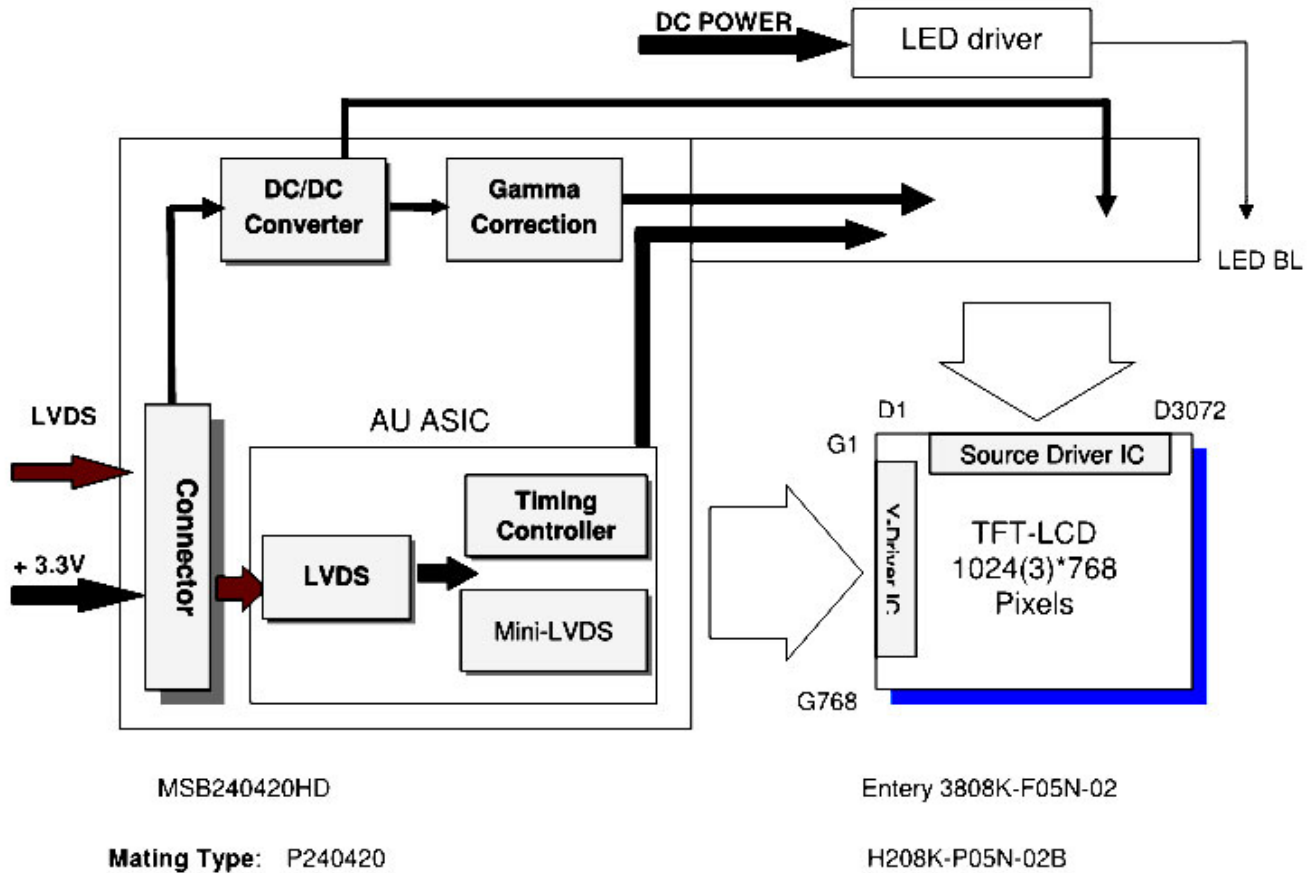

4. Absolute Maximum Ratings

4.1 Absolute Ratings of TFT LCD Module

| Item | Symbol | Min | Max | Unit |
|-------------------------|--------|------|------|--------|
| Logic/LCD Drive Voltage | Vin | -0.3 | +3.6 | [Volt] |

4.2 Absolute Ratings of Environment

| Item | Symbol | Min | Max | Unit |
|-----------------------|--------|-----|------|-------|
| Operating Temperature | TOP | 0 | +65* | [°C] |
| Operation Humidity | HOP | 8 | 90 | [%RH] |
| Storage Temperature | TST | -20 | +65 | [°C] |
| Storage Humidity | HST | 8 | 90 | [%RH] |

Note: Maximum Wet-Bulb should be 39°C and no condensation.

* 65 °C is panel surface temperature

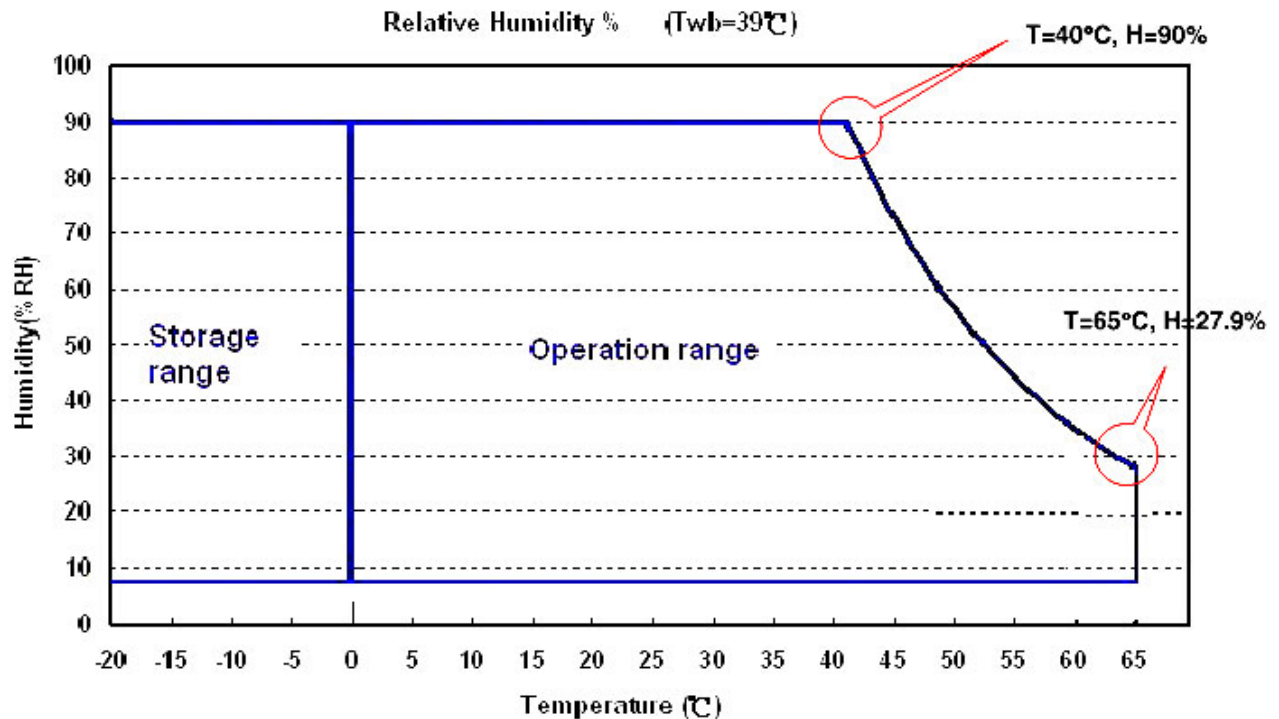

5.1 TFT LCD Module

5.1.1 Power Specification

| Symbol | Parameter | Min | Typ | Max | Units | Remark |
|--------|-------------------------|-----|-----|-----|--------|--------|
| VDD | Logic/LCD Drive Voltage | 3.0 | 3.3 | 3.6 | [Volt] | ± 10% |
| IDD | VDD Current | - | 1 | 1.5 | [A] | |
| Irush | LCD Inrush Current | | | 3 | [A] | Note 1 |
| PDD | VDD Power | - | 3.3 | 5 | [Watt] | |

Note 1: Measurement condition:

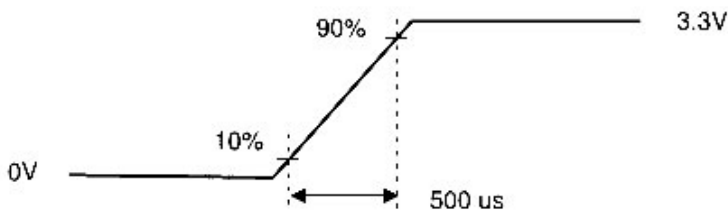
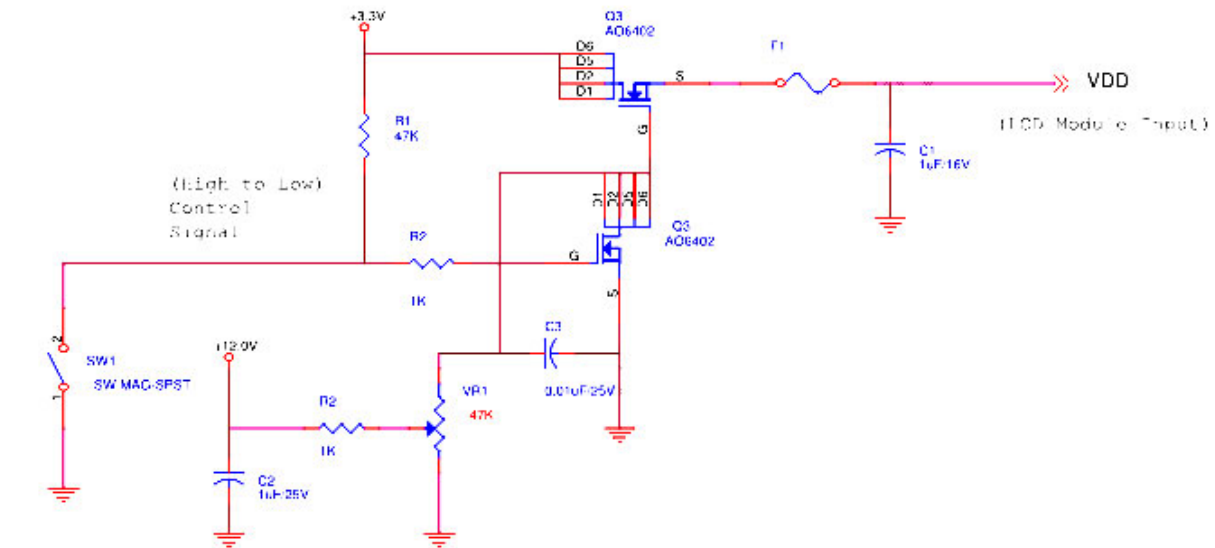

VDD rising time



64 Gray pattern

5.1.2 Signal Electrical Characteristics

Input signals shall be low or Hi-Z state when VDD is off.

| Symbol | Item | Min. | Typ. | Max. | Unit | Remark |
|--------|--|------|------|------|------|----------------|
| VTH | Differential Input High Threshold | - | - | 100 | [mV] | VCM=1.2V |
| VTL | Differential Input Low Threshold | -100 | - | - | [mV] | VCM=1.2V |
| VID | Input Differential Voltage | 100 | 400 | 600 | [mV] | |
| VICM | Differential Input Common Mode Voltage | 1.1 | | 1.45 | [V] | VTH/VTL=-100mV |

Note: LVDS Signal Waveform.

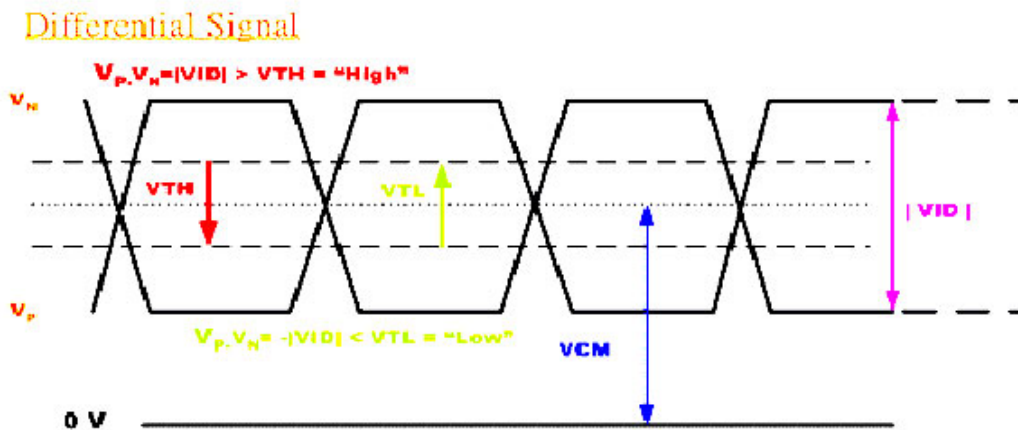

5.2 Backlight Unit

5.2.1 Parameter guideline for LED

Following characteristics are measured under stable condition using a LED driving board at 25°C (Room Temperature).

| Symbol | Parameter | Min. | Typ. | Max. | Unit | Remark |
|----------------|-----------------------|--------|-------|------|------|--------------|
| Vcc | Input Voltage | 10.8 | 12 | 13.2 | Volt | |
| Ivcc | Input Current | - | 0.375 | | A | 100% Dimming |
| PLED | Power Consumption | - | 4.5 | 5 | Watt | 100% Dimming |
| Irush | Inrush Current | | | 1 | A | |
| VLED on/off | On Control Voltage | 2.5 | 3.3 | 5.5 | Volt | |
| | Off Control Voltage | | | 0.5 | Volt | |
| FPWM | PWM Dimming Frequency | 200 | | 10k | Hz | |
| | High Voltage | 2.5 | 3.3 | 5.5 | Volt | |
| | Low Voltage | | | 0.5 | Volt | |
| | Dimming Duty Cycle | 5 | - | 100 | % | |
| I _F | LED Forward Current | | 60 | | mA | Ta = 25°C |
| Operating Life | | 50,000 | | | Hrs | Ta = 25°C |

Note 1: Ta means ambient temperature of TFT-LCD module.

Note 2: If G150XTN03.6 module is driven at high ambient temperature & humidity condition. The operating life will be reduced.

Note 3: Definition of life time: LED brightness becomes 50% of its original value. The minimum life time of LED unit is defined at the condition of I_{RLED} = 50 mA and 25±2°C (Room temperature).



6.3 Signal Description

LVDS is a differential signal technology for LCD interface and high speed data transfer device.

| MSB240420E(STM) | | |
|-----------------|--------|--|
| Pin No. | Symbol | Description |
| 1 | VDD | Power Supply, 3.3V (typical) |
| 2 | VDD | Power Supply, 3.3V (typical) |
| 3 | NC | No Connect |
| 4 | NC | No Connect |
| 5 | Rin1- | - LVDS differential data input (R0-R5, G0) |
| 6 | Rin1+ | + LVDS differential data input (R0-R5, G0) |
| 7 | VSS | Ground |
| 8 | Rin2- | - LVDS differential data input (G1-G5, B0-B1) |
| 9 | Rin2+ | + LVDS differential data input (G1-G5, B0-B1) |
| 10 | VSS | Ground |
| 11 | Rin3- | - LVDS differential data input (B2-B5, HS, VS, DE) |
| 12 | Rin3+ | + LVDS differential data input (B2-B5, HS, VS, DE) |
| 13 | VSS | Ground |
| 14 | ClkIN- | - LVDS differential clock input |
| 15 | ClkIN+ | + LVDS differential clock input |
| 16 | GND | Ground |
| 17 | Rin4- | - LVDS differential data input (R6-R7, G6-G7, B6-B7) |
| 18 | Rin4+ | + LVDS differential data input (R6-R7, G6-G7, B6-B7) |
| 19 | VSS | Ground |
| 20 | SEL6/8 | Select 6 or 8 Bits LVDS Input |

Note 1: Input signals shall be in low status when VDD is off.

Note 2: For 6 bits mode, please keep the Pin 17& Pin 18 NC or make sure that the voltage of Pin 18 is always higher than the voltage of Pin 17.



6.4 The Input Data Format

6.4.1 SEL68

SEL68 = "High" for 6 bits LVDS Input

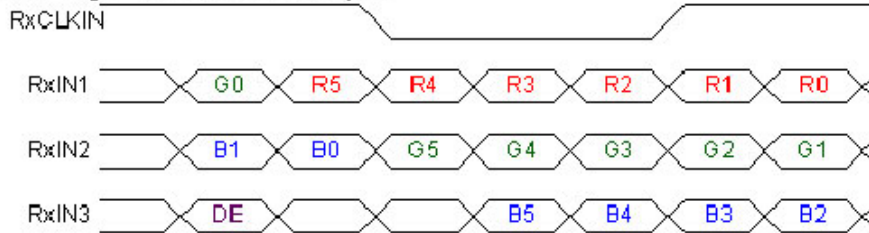

SEL68 = "Low" or "NC" for 8 bits LVDS Input

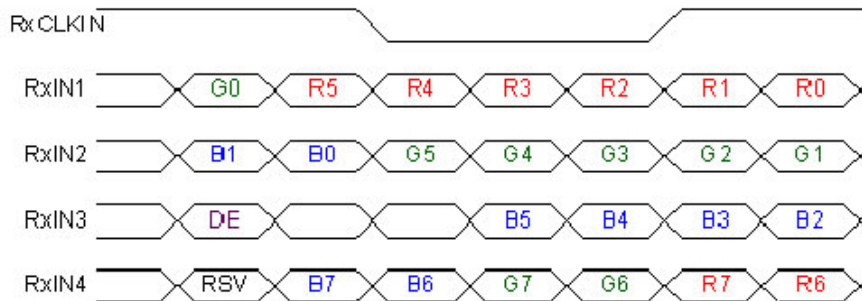

Note1: Please follow PSWG.

Note2: R/G/B data 7:MSB, R/G/B data 0:LSB

| Signal Name | Description | Remark |
|-------------|--------------------|---|
| R7 | Red Data 7 | Red-pixel Data |
| R6 | Red Data 6 | |
| R5 | Red Data 5 | |
| R4 | Red Data 4 | |
| R3 | Red Data 3 | |
| R2 | Red Data 2 | |
| R1 | Red Data 1 | |
| R0 | Red Data 0 | |
| G7 | Green Data 7 | Green-pixel Data |
| G6 | Green Data 6 | |
| G5 | Green Data 5 | |
| G4 | Green Data 4 | |
| G3 | Green Data 3 | |
| G2 | Green Data 2 | |
| G1 | Green Data 1 | |
| G0 | Green Data 0 | |
| B7 | Blue Data 7 | Blue-pixel Data |
| B6 | Blue Data 6 | |
| B5 | Blue Data 5 | |
| B4 | Blue Data 4 | |
| B3 | Blue Data 3 | |
| B2 | Blue Data 2 | |
| B1 | Blue Data 1 | |
| B0 | Blue Data 0 | |
| RxCLKIN | LVDS Data Clock | |
| DE | Data Enable Signal | When the signal is high, the pixel data shall be valid to be displayed. |

Note: Output signals from any system shall be low or Hi-Z state when VDD is off.



6.5 Interface Timing

6.5.1 Timing Characteristics

| Signal | Parameter | Symbol | Min. | Typ. | Max. | Unit | |
|--------------|--------------------|---------------|----------|------|------|------|-------------|
| Clock Timing | Clock frequency | $1/T_{Clock}$ | 50 | 65 | 81 | MHz | |
| Vsync Timing | Vertical Section | Period | T_V | 783 | 806 | 968 | T_{Line} |
| | | Active | T_{VD} | 768 | 768 | 768 | |
| | | Blanking | T_{VB} | 15 | 38 | 200 | |
| Hsync Timing | Horizontal Section | Period | T_H | 1224 | 1344 | 2024 | T_{Clock} |
| | | Active | T_{HD} | 1024 | 1024 | 1024 | |
| | | Blanking | T_{HB} | 200 | 320 | 1000 | |

Note: Support DE mode only.

Note : Typical value refer to VESA STANDARD

6.5.2 Input Timing Diagram

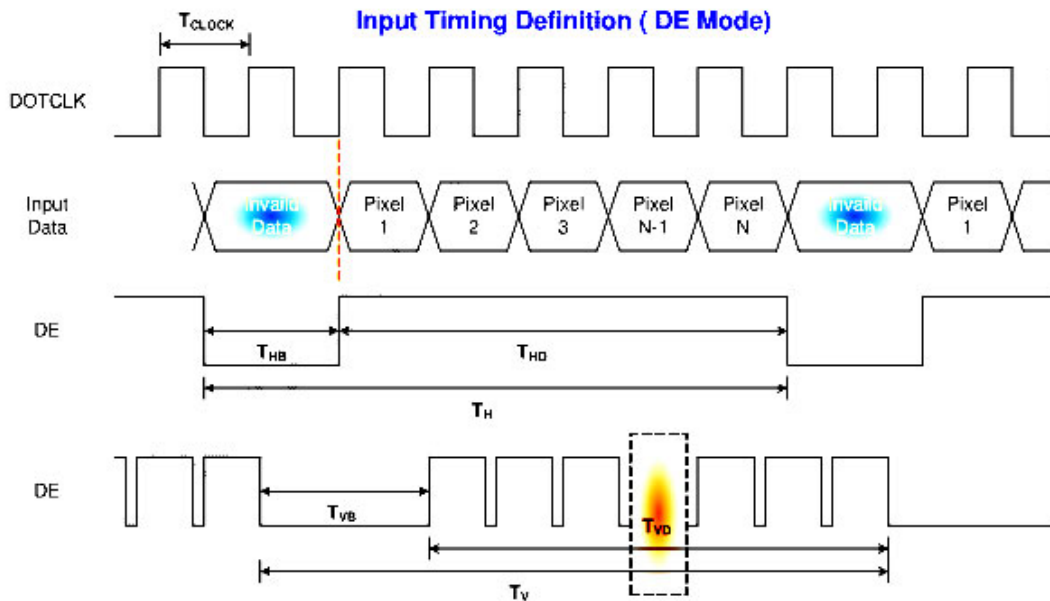

6.6 Power ON/OFF Sequence

VDD power and backlight on/off sequence is as below. Interface signals are also shown in the chart. Signals from any system shall be Hi-Z state or low level when VDD is off.

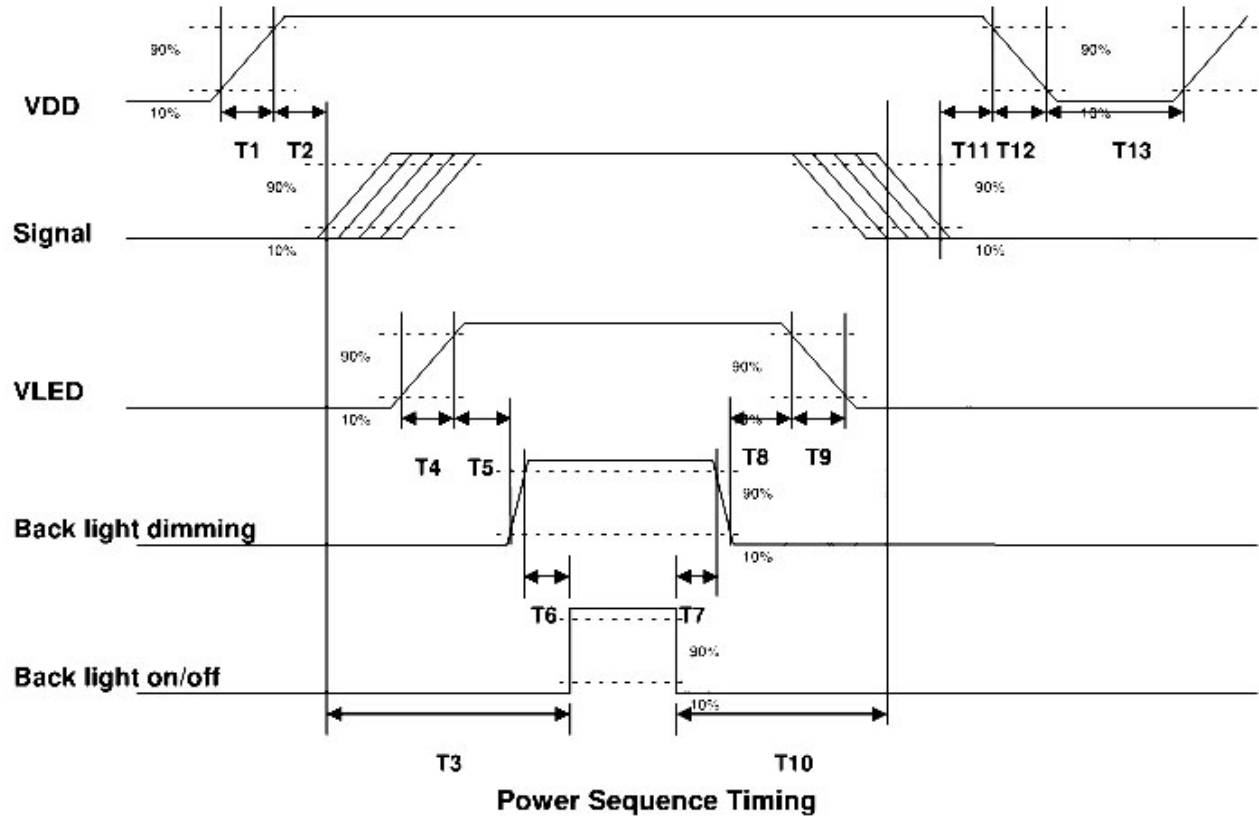

| Parameter | Value | | | Unit |
|-----------|-------|------|------|------|
| | Min. | Typ. | Max. | |
| T1 | 0.5 | - | 10 | [ms] |
| T2 | 30 | 40 | 50 | [ms] |
| T3 | 200 | - | - | [ms] |
| T4 | 0.5 | - | 10 | [ms] |
| T5 | 10 | - | - | [ms] |
| T6 | 10 | - | - | [ms] |
| T7 | 0 | - | - | [ms] |
| T8 | 10 | - | - | [ms] |
| T9 | - | - | 10 | [ms] |
| T10 | 110 | - | - | [ms] |
| T11 | 0 | 16 | 50 | [ms] |
| T12 | - | - | 10 | [ms] |
| T13 | 1000 | - | - | [ms] |

The above on/off sequence should be applied to avoid abnormal function in the display. Please make sure to turn off the power when you plug the cable into the input connector or pull the cable out of the connector.



7. Connector & Pin Assignment

Physical interface is described as for the connector on module. These connectors are capable of accommodating the following signals and will be following components.

7.1 TFT LCD Module: LVDS Connector

| Connector Name / Designation | Signal Connector |
|------------------------------|-------------------|
| Manufacturer | STM or compatible |
| Connector Model Number | MSB240420HD |
| Adaptable Plug | P240420 |

| Pin# | Signal Name | Pin# | Signal Name |
|------|-------------|------|-------------|
| 1 | VDD | 2 | VDD |
| 3 | NC | 4 | NC |
| 5 | Rin0- | 6 | Rin0+ |
| 7 | VSS | 8 | Rin1- |
| 9 | Rin1+ | 10 | VSS |
| 11 | Rin2- | 12 | Rin2+ |
| 13 | VSS | 14 | ClkIN- |
| 15 | ClkIN+ | 16 | GND |
| 17 | Rin3- | 18 | Rin3+ |
| 19 | VSS | 20 | SEL68 |



7.1.1 Connector Illustration

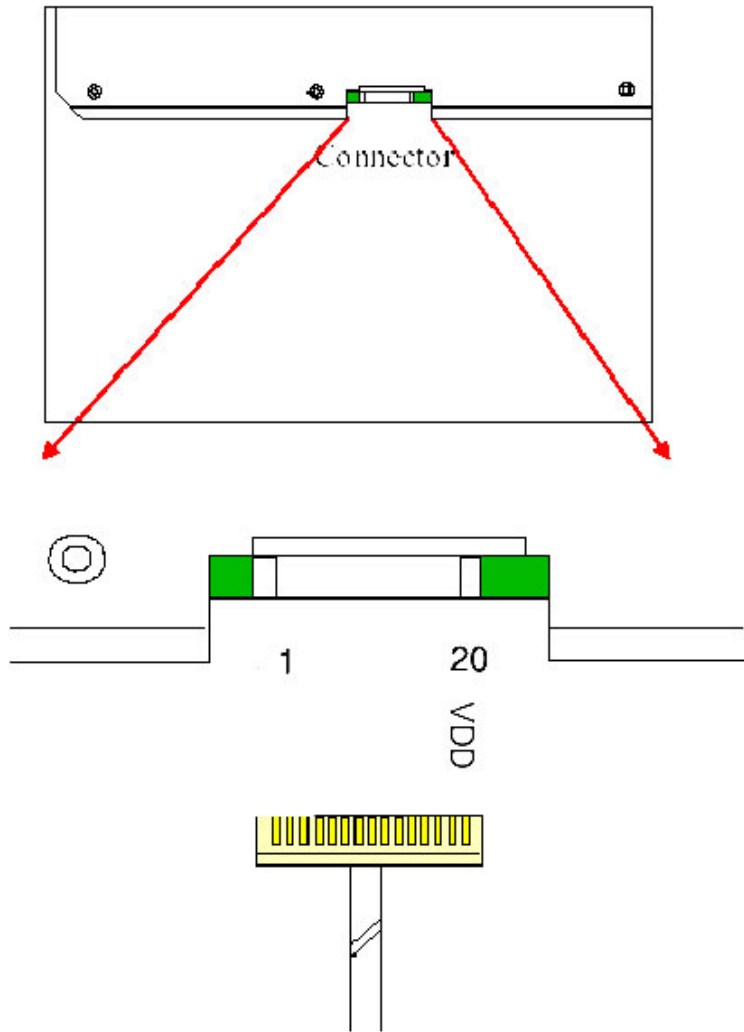

7.2 LED Backlight Unit: LED Driver Connector

| Connector Name / Designation | LED Connector |
|------------------------------|------------------------------|
| Manufacturer | Entery or compatible |
| Connector Model Number | 3808K-F05N-02 or compatible |
| Mating Model Number | H208K-P05N-02B or compatible |

7.3 LED Driver Connector Pin Assignment

| Pin# | Symbol | Signal Name |
|------|---------|-------------|
| 1 | Vcc | 12V |
| 2 | GND | GND |
| 3 | Enable | VLED On/Off |
| 4 | Dimming | PWM Dimming |
| 5 | NC | NC |



8. Reliability Test Criteria

| Items | Required Condition | Note |
|--------------------------------|---|--------|
| Temperature Humidity Bias | 50°C/80%,300 hours | |
| High Temperature Operation | 60°C,300 hours | |
| Low Temperature Operation | 0°C,300 hours | |
| Hot Storage | 65°C,300 hours | |
| Cold Storage | -20°C,300 hours | |
| Thermal Shock Test | -20°C/30 min ,60°C/30 min ,100cycles | |
| Shock Test (Non-Operating) | 50G,20ms,Half-sine wave,(±X, ±Y, ±Z) | |
| Vibration Test (Non-Operating) | 1.5G, (10~200~10Hz, P-P) 30 mins/axis (X, Y, Z) | |
| On/off test | On/10 sec, Off/10 sec, 30,000 cycles | |
| ESD | Contact Discharge: ± 8KV, 150pF(330Ω) 1sec, 8 points, 25 times/ point Air Discharge: ± 15KV, 150pF(330Ω) 1sec, 8 points, 25 times/ point | Note 1 |

Note1: According to EN61000-4-2, ESD class B: Some performance degradation allowed. No data lost
Self-recoverable. No hardware failures.

Note 2:

- Water condensation is not allowed for each test items.
- Each test is done by new TFT-LCD module. Don't use the same TFT-LCD module repeatedly for reliability test.
- The reliability test is performed only to examine the TFT-LCD module capability.
- To inspect TFT-LCD module after reliability test, please store it at room temperature and room humidity for 24 hours at least in advance.
- No function failure occurs.





G150XTN03.6

9.2 CM Outline Dimension (Rear View)

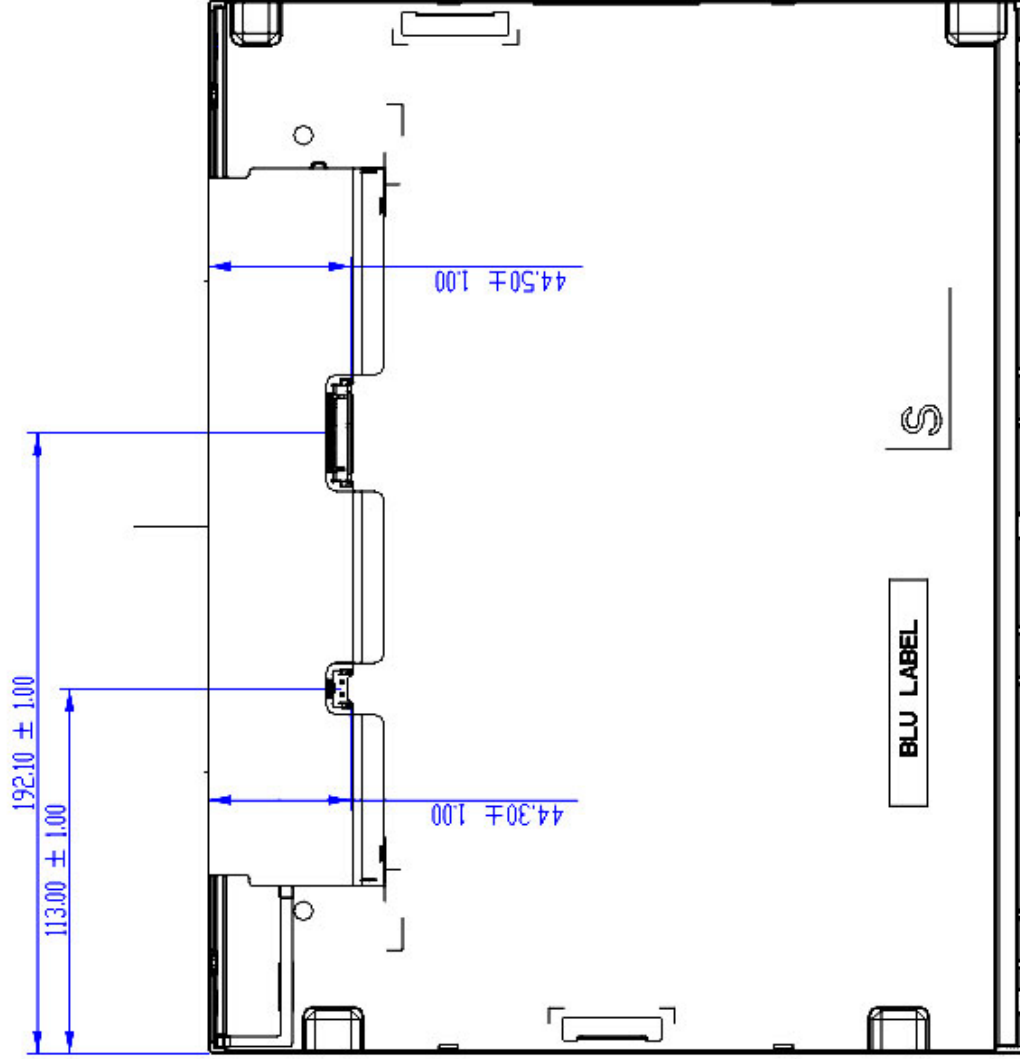

10. Label and Packaging

10.1 Shipping Label (on the rear side of TFT-LCD display)



10.2 Carton Package

Max capacity : 19 TFT-LCD module per carton
 Max weight: 20 kg per carton
 Outside dimension of carton: 430mm(L)* 370mm(W)*350mm(H)
 Pallet size : 1140 mm * 890 mm * 132mm

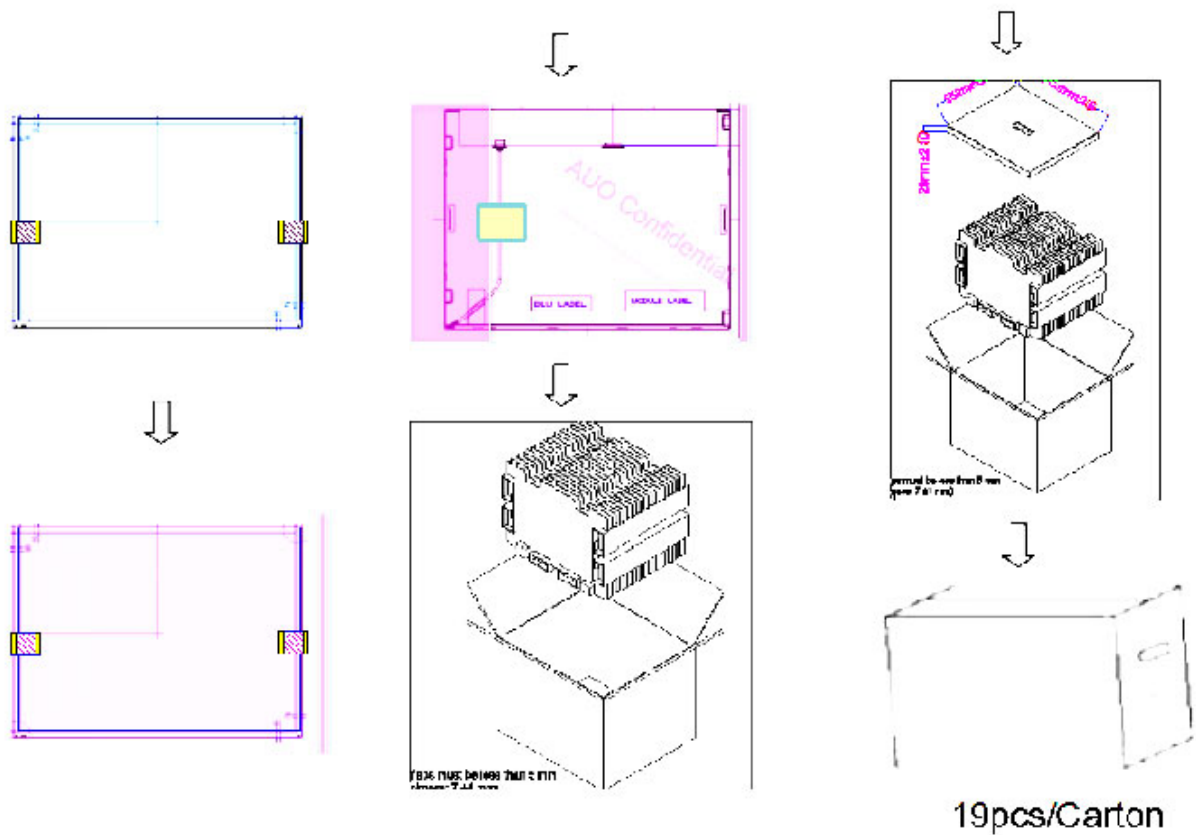

10.3 Palletizing

Module by air_Max: (2 *3) *4 layers , one pallet put 24 boxes , total 456pcs module

Module by sea_Max: (2 *3) *4 layers + (2 *3) *1 layers , two pallet put 30 boxes , total570pcs module

Module by sea_HQ_Max: (2 *3) *4 layers+(2 *3) *2 layers, two pallet put 36 boxes, total684pcs module

| | NO. SHIPPING BY AIR | NO. SHIPPING BY SEA | NO. SHIPPING BY SEA_HQ |
|-------------------------|---------------------------|---------------------------|---------------------------|
| MODULE / CARTON | 12 | 12 | 12 |
| CARTON / LAYER | 6 | 6 | 6 |
| LAYER / PALLET | 4 | 4+1 | 4+2 |
| MODULE / PALLET | 360 | 450 | 540 |
| CARTON SIZE(MM) | 1140(L) X 890(W) X 135(H) | 1140(L) X 890(W) X 135(H) | 1140(L) X 890(W) X 135(H) |
| PALLET SIZE(MM) | 1140(L) X 890(W) X 135(H) | 1140(L) X 890(W) X 135(H) | 1140(L) X 890(W) X 135(H) |
| TOTAL PALLET HEIGHT(MM) | 1512 | 2133 | 2133 |
| TOTAL PALLET WEIGHT(KG) | 492 | 656 | 746 |

ONE PALLET SHIPMENT EXAMPLE SHIPPING BY AIR USED

TWO PALLETS SHIPMENT EXAMPLE SHIPPING BY SEA USED

TWO PALLETS SHIPMENT EXAMPLE SHIPPING BY SEA_HQ USED



11 Safety

11.1 Sharp Edge Requirements

There will be no sharp edges or comers on the display assembly that could cause injury.

11.2 Materials

11.2.1 Toxicity

There will be no carcinogenic materials used anywhere in the display module. If toxic materials are used, they will be reviewed and approved by the responsible AUO toxicologist.

11.2.2 Flammability

All components including electrical components that do not meet the flammability grade UL94-V1 in the module will complete the flammability rating exception approval process.

The printed circuit board will be made from material rated 94-V1 or better. The actual UL flammability rating will be printed on the printed circuit board.

11.3 Capacitors

If any polarized capacitors are used in the display assembly, provisions will be made to keep them from being inserted backwards.

11.4 National Test Lab Requirement

The display module will satisfy all requirements for compliance to:

UL 60950-1, Second Edition

U.S.A. Information Technology Equipment

