

# TFT-DISPLAY DATASHEET

AUO  
Model: G140HAN01.1

## BRIEF SPEC.:

Main Feature

Landscape  
White LED Backlight

---

Active Screen Area	309.37 x 174.02 (mm)
Diagonal   Format	14"   16:9
Resolution	1920 X 1080
Colors	262K/16.7M (6/8Bit)
Backlight	LED
Brightness	400 cd/m <sup>2</sup>
LED Life Time	50K(h)
Interface	eDP
Viewing Angle	89/89 L/R 89/89
Touchscreen	No
Power Supply	3.3 V
Module Outline	319.0 x 190.76 x 7.8 (mm)
Operation Temperature	0 ... +50 °C
Storage Temperature	-20... +60 °C
Surface Treatment	Glare, Hardness 3H



# Product Specification

AU OPTRONICS CORPORATION

( ) Preliminary Specifications

(v) Final Specifications

<b>Module</b>	14" inch Color TFT-LCD
<b>Model Name</b>	G140HAN01.1

<i>Customer</i>	<i>Date</i>
_____	_____
<i>Checked &amp; Approved by</i>	<i>Date</i>
_____	_____
<i>Customer's sign back page</i>	

<b>Approved by</b>	<b>Date</b>
Sean Lin	2018.12 17
<b>Prepared by</b>	<b>Date</b>
Jason Hsieh	2018.12 17
General Display Business Division / AU Optronics corporation	



## Contents

<b>1. Operating Precautions</b> .....	<b>4</b>
<b>2. General Description</b> .....	<b>5</b>
2.1 Display Characteristics .....	5
2.2 Optical Characteristics .....	6
<b>3. Functional Block Diagram</b> .....	<b>9</b>
<b>4. Absolute Maximum Ratings</b> .....	<b>10</b>
4.1 Absolute Ratings of TFT LCD Module .....	10
4.2 Absolute Ratings of Environment .....	10
<b>5. Electrical Characteristics</b> .....	<b>11</b>
5.1 TFT LCD Module .....	11
5.2 Backlight Unit .....	13
<b>6. Signal Characteristic</b> .....	<b>14</b>
6.1 Pixel Format Image .....	14
6.2 Integration Interface Requirement .....	15
6.3 Interface Timing .....	17
6.4 Power ON / OFF Sequence .....	18
<b>7. Reliability Test Criteria</b> .....	<b>20</b>
<b>8. Mechanical Characteristics</b> .....	<b>22</b>
8.1 LCM Outline Dimension .....	22
<b>9. Label and Packaging</b> .....	<b>24</b>
9.1 Shipping Label (on the rear side of TFT-LCD display) .....	24
9.2 Carton Package .....	24



# Product Specification

AU OPTRONICS CORPORATION

## Record of Revision

Version	Date (yyyy/m/d)	Page	Old description	New Description
0.0	2018/1/5	All	First draft specification	
1.0	2018/12/17	5	<b>2.1 Display Characteristics</b> Weight : 470g	<b>2.1 Display Characteristics</b> Weight : 580g
		24	<b>9.2 Carton Package</b> Module by air : (2 *3) *3 layers , one pallet put 18 boxes , total 396pcs module One pallet (2 *3) *3 layers + One pallet (2 *3) *1 layers , total 528pcs module Module by sea_ HQ : One pallet (2 *3) *3 layers + One pallet (2 *3) *2ayers Total 660pcs module	<b>9.2 Carton Package</b> Max capacity : 22 pcs TFT-LCD module per carton Max weight: 14.56 kg per carton Outside dimension of carton: 484(L) mm x 279(W) mm x 432(H) mm Pallet size : 1150 * 910 * 132mm Module by air : (2 *3) *3 layers , one pallet put 18 boxes , total 396pcs module Module by sea : One pallet (2 *3) *3 layers + One pallet (2 *3) *1 layers , total 528pcs module Module by sea_ HQ : One pallet (2 *3) *3 layers + One pallet (2 *3) *2ayers Total 660pcs module



## 1. Operating Precautions

- 1) Since front polarizer is easily damaged, please be cautious and not to scratch it.
- 2) Be sure to turn off power supply when inserting or disconnecting from input connector.
- 3) Wipe off water drop immediately. Long contact with water may cause discoloration or spots.
- 4) When the panel surface is soiled, wipe it with absorbent cotton or soft cloth.
- 5) Since the panel is made of glass, it may be broken or cracked if dropped or bumped on hard surface.
- 6) To avoid ESD (Electro Static Discharge) damage, be sure to ground yourself before handling TFT-LCD Module.
- 7) Do not open nor modify the module assembly.
- 8) Do not press the reflector sheet at the back of the module to any direction.
- 9) In case if a module has to be put back into the packing container slot after it was taken out from the container, do not press the center of the LED light bar edge. Instead, press at the far ends of the LED light bar edge softly. Otherwise the TFT Module may be damaged.
- 10) At the insertion or removal of the Signal Interface Connector, be sure not to rotate nor tilt the Interface Connector of the TFT Module.
- 11) TFT-LCD Module is not allowed to be twisted & bent even force is added on module in a very short time. Please design your display product well to avoid external force applying to module by end-user directly.
- 12) Small amount of materials having no flammability grade is used in the LCD module. The LCD module should be supplied by power complied with requirements of Limited Power Source (IEC60950 or UL1950), or be applied exemption.
- 13) Severe temperature condition may result in different luminance, response time and lamp ignition voltage.
- 14) Continuous operating TFT-LCD display under low temperature environment may accelerate lamp exhaustion and reduce luminance dramatically.
- 15) The data on this specification sheet is applicable when LCD module is placed in landscape position.
- 16) Continuous displaying fixed pattern may induce image sticking. It's recommended to use screen saver or shuffle content periodically if fixed pattern is displayed on the screen.



## 2. General Description

This specification applies to the Color Active Matrix Liquid Crystal Display G140HAN01.1 composed of a TFT-LCD display, a driver and power supply circuit, and a LED backlight system. The screen format is intended to support the 16:9 FHD, 1920(H)X1080(V) screen and 262K colors with LED backlight driving circuit. All input signals are eDP(Embedded Display Port) interface compatible.

### 2.1 Display Characteristics

The following items are characteristics summary on the table under 25 °C condition:

Items	Unit	Specifications
Screen Diagonal	[mm]	354.95
Active Area	[mm]	309.37mm x 174.02mm
Resolution		1920 (H) x 3(RGB) x 1080 (V)
Pixel Pitch	[mm]	0.161(H) x 0.161 (V)
Pixel Arrangement		RGB Vertical Strip
Display Mode		Normal Black
Nominal Input Voltage VDD	[Volt]	+3.3V typ
Power Consumption	[Watt]	7.2W Max (include logic and Blu power)
Weight	[Grams]	580g Max
Physical Size	[mm]	319mm(H)x190.76mm(V)x7.8mm(D) (typ.), non PCBA side 4.9mm , ,
Electrical Interface		2 lan eDP 1.2
Surface Treatment		Glare, Hardness 3H
Support Color		6 bit + FRC
Temperature Range Operating Storage (Non-Operating)	[°C] [°C]	0 ~ +50 -20 ~ +60
RoHS Compliance		RoHS Compliance

## 2.2 Optical Characteristics

The optical characteristics are measured under stable conditions at 25 °C (Room Temperature):

Item	Unit	Conditions	Min.	Typ.	Max.	Note
White Luminance	cd/m <sup>2</sup>		320	400		1
Uniformity	%	5 points	75			2,3
Contrast Ratio	--			800		4
Response Time	msec	Rising		15	20	5
		Falling		10	15	
		Rising + Falling		25	35	
Viewing Angle	degree	Horizontal CR >= 10	(Right)	85	89	6
			(Left)	85	89	
		Vertical CR >= 10	(Upper)	85	89	
			(Lower)	85	89	
Color / Chromaticity Coordinates (CIE 1931)	--	Red x	0.584	0.634	0.684	
		Red y	0.283	0.333	0.383	
		Green x	0.257	0.307	0.357	
		Green y	0.565	0.615	0.665	
		Blue x	0.108	0.158	0.208	
		Blue y	0.003	0.053	0.103	
		White x	0.263	0.313	0.363	
		White y	0.279	0.329	0.379	
Color Gamut	%			72		

Note 1: Measurement method

Equipment Pattern Generator, Power Supply, Digital Voltmeter, Luminance meter (SR\_3 or equivalent)

Aperture 1φ with 50cm viewing distance

Test Point Center

Environment < 1 lux

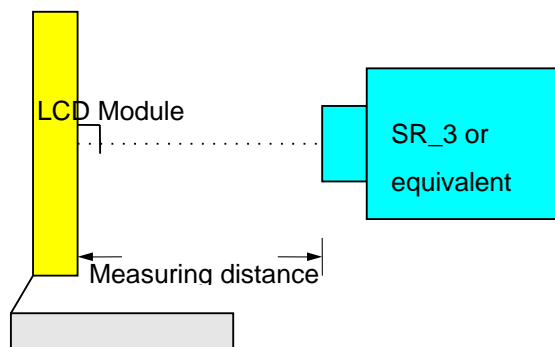

Note 2: Definition of 5 points position

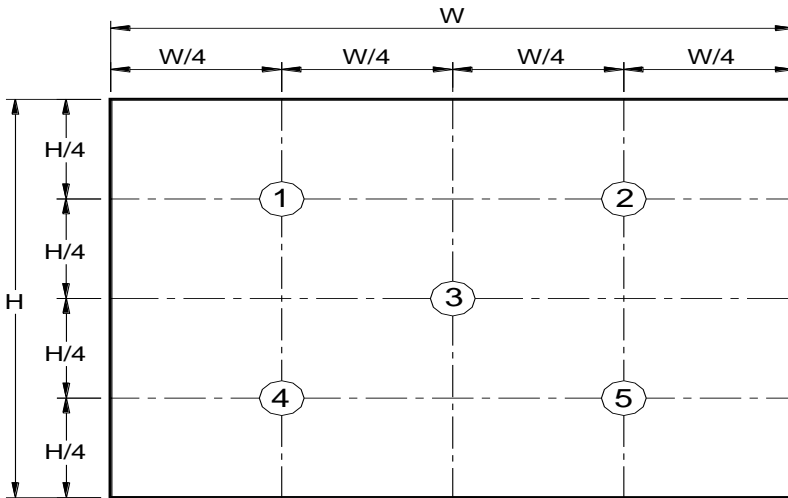

Note 3: The luminance uniformity of 5 points is defined by dividing the minimum luminance values by the maximum test point luminance

$$\delta_{w5} = \frac{\text{Minimum Brightness of five points}}{\text{Maximum Brightness of five points}}$$

Note 4: Definition of contrast ratio (CR):

$$\text{Contrast ratio (CR)} = \frac{\text{Brightness on the "White" state}}{\text{Brightness on the "Black" state}}$$

Note 5: Definition of response time:

The output signals of photo detector are measured when the input signals are changed from "White" to "Black" (falling time) and from "Black" to "White" (rising time), respectively. The response time interval is between 10% and 90% of amplitudes. Please refer to the figure as below.

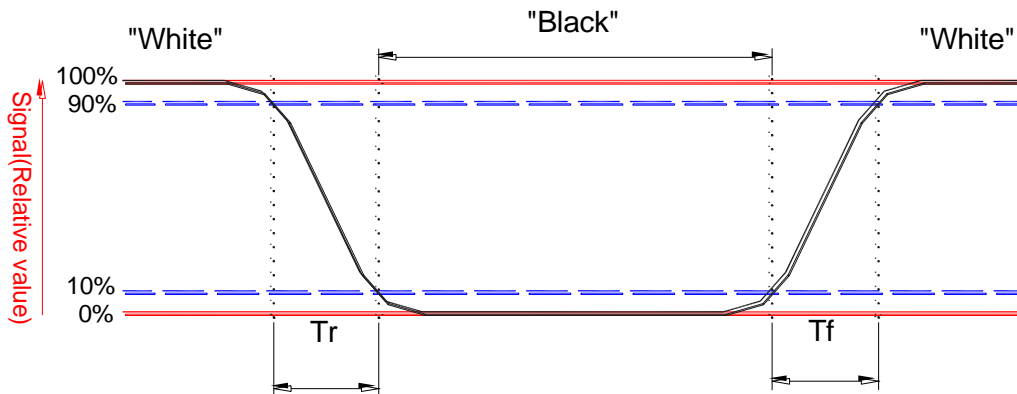



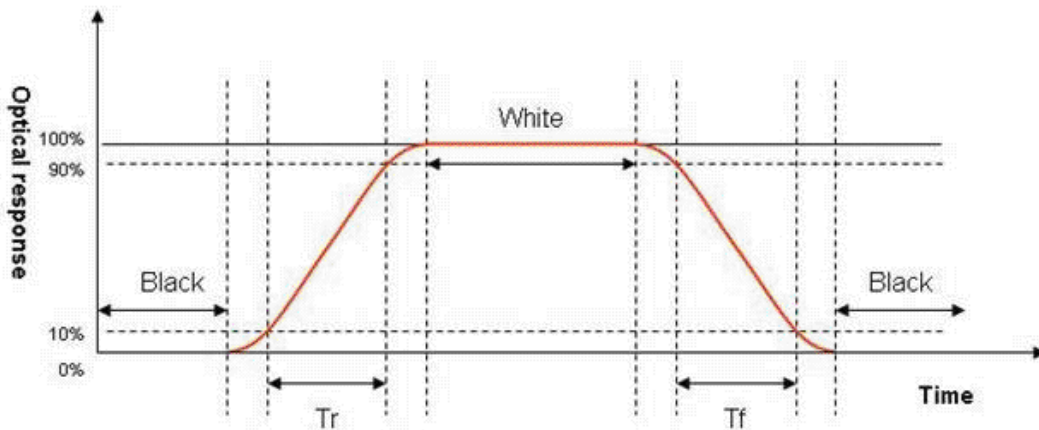

Note 6: Definition of viewing angle

Viewing angle is the measurement of contrast ratio  $\geq 10$ , at the screen center, over a  $180^\circ$  horizontal and  $180^\circ$  vertical range (off-normal viewing angles). The  $180^\circ$  viewing angle range is broken down as below:  $90^\circ$  ( $\theta$ ) horizontal left and right, and  $90^\circ$  ( $\phi$ ) vertical high (up) and low (down). The measurement direction is typically perpendicular to the display surface with the screen rotated to its center to develop the desired measurement viewing angle.

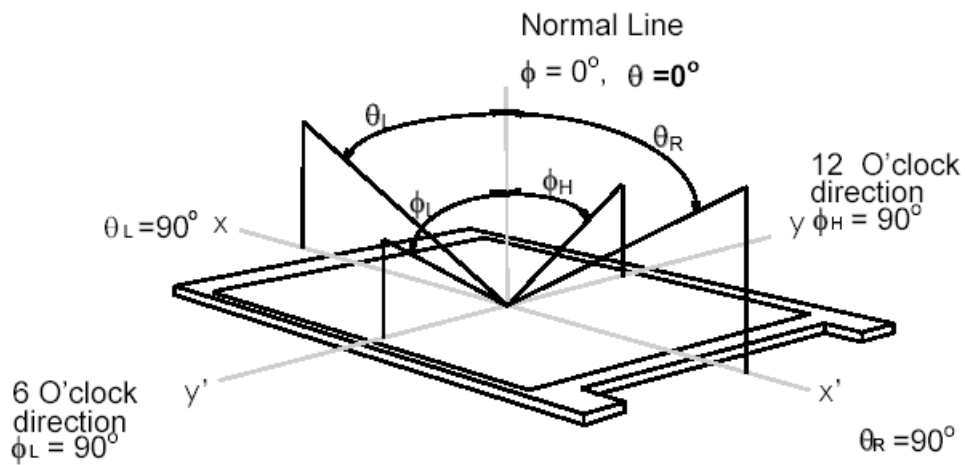

## 3. Functional Block Diagram

The following diagram shows the functional block of the 14 inch color TFT/LCD module:

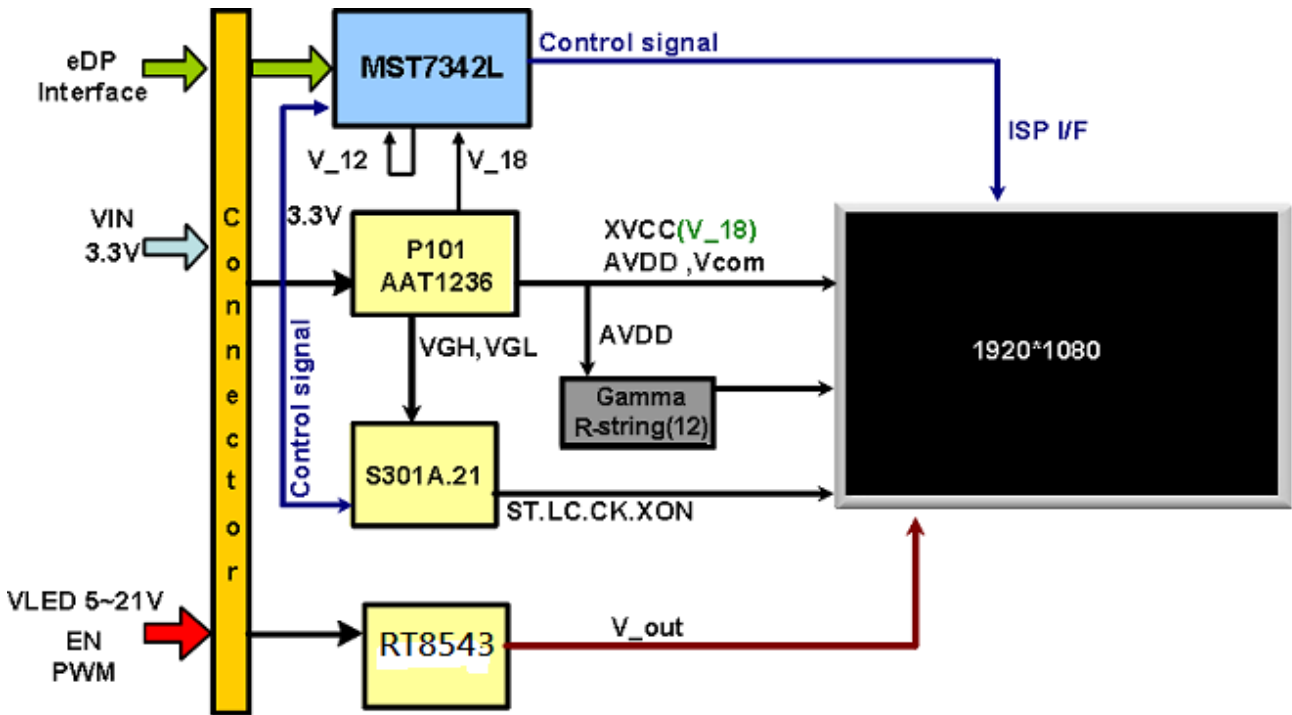

## 4. Absolute Maximum Ratings

### 4.1 Absolute Ratings of TFT LCD Module

Item	Symbol	Min	Max	Unit
Logic/LCD drive Voltage	Vin	-0.3	+4.0	[Volt]

### 4.2 Absolute Ratings of Environment

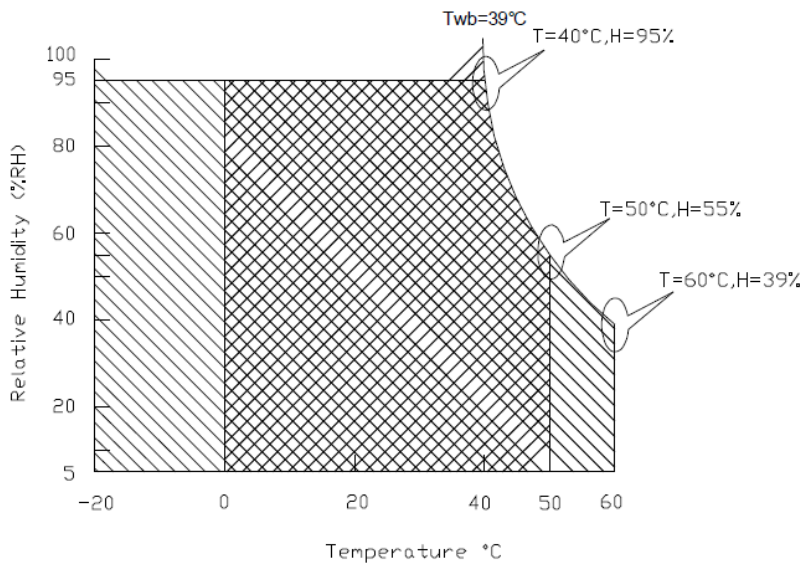

Item	Symbol	Min	Max	Unit
Operating Temperature	TOP	0	50	[°C]
Operation Humidity	HOP	5	95	[%RH]
Storage Temperature	TST	-20	60	[°C]
Storage Humidity	HST	5	95	[%RH]

Note: Maximum Wet-Bulb should be 39 °C and no condensation.



Operating Range 

Storage Range

 + 

## 5. Electrical Characteristics

### 5.1 TFT LCD Module

Input power specifications are as follows; The power specification are measured under 25°C and frame frequency under 60Hz

Symble	Parameter	Min	Typ	Max	Units	Note
VDD	Logic/LCD Drive Voltage	3.0	3.3	3.6	[Volt]	
PDD	VDD Power			1.1	[Watt]	1
IDD	IDD Current			367	[mA]	1
IRush	Inrush Current			2000	[mA]	2
VDDrp	Allowable Logic/LCD Drive Ripple Voltage			100	[mV] p-p	

Note 1 : Maximum Measurement Condition : Mosaic pattern (PDD (max) = VDD(min) x IDD(max))

Note 2 : Measure Condition

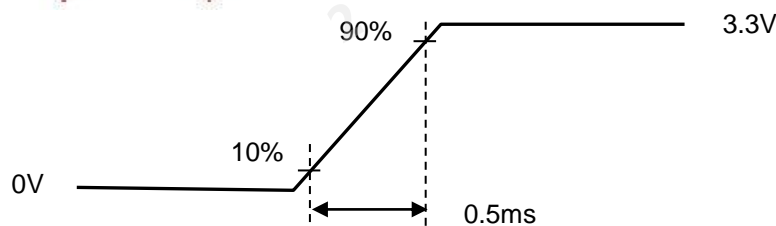
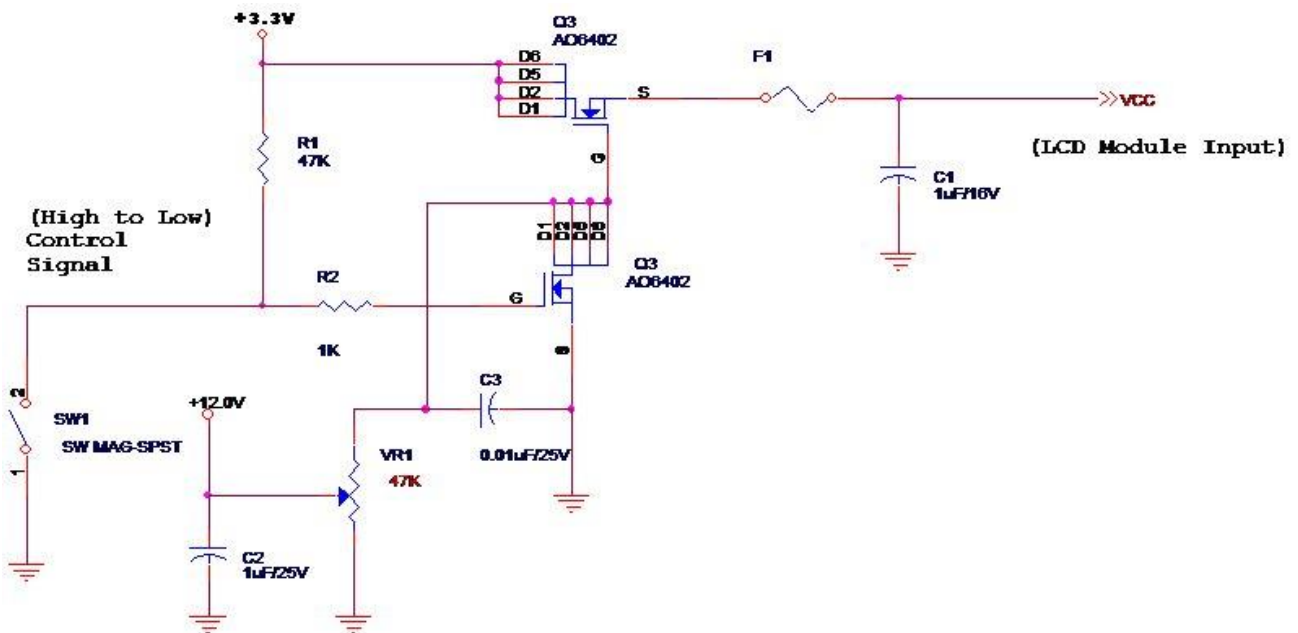

Vin rising time

## 5.1.2 Signal Electrical Characteristics

Input signals shall be low or High-impedance state when VDD is off.

### Display Port main link signal:

Signal electrical characteristics are as follows;

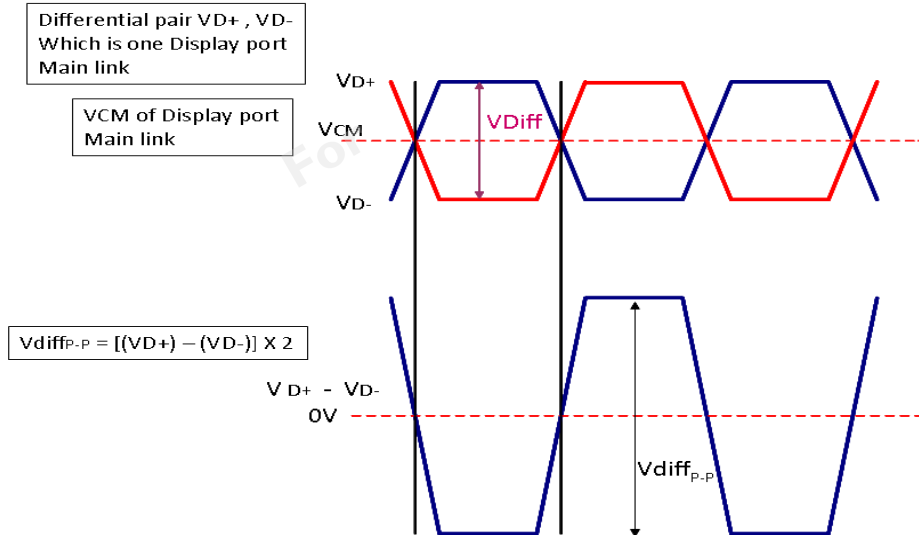

Symble	Parameter	Min	Typ.	Max	Unit
VCM	RX input DC Common Mode Voltage		0		V
VDiffP-P	Peak-to-peak Voltage at a receiving Device	150		1320	mV

Follow as VESA display port standard V1.3

### Display Port VHPD signal:

Symble	Parameter	Min	Typ	Max	Unit	Note
VHPD	HPD Voltage	2.25		3.6	V	

Follow as VESA display port standard V1.



## 5.2 Backlight Unit

### Parameter guideline for LED

Following characteristics are measured under a stable condition using an inverter at 25°C (Room Temperature):

### LED characteristics

Symbol	Parameter	Min	Typ	Max	Units	Condition
PLED	Backlight Power Consumption	--	5.54	6.1	[Watt]	Ta = 25°C, Note 1 Vin =12V
LTLED	LED Life-Time	50000	--	--	Hour	Ta = 25°C, Note2

**Note 1:** Calculator value for reference  $P_{LED} = V_F$  (Normal Distribution) \*  $I_F$  (Normal Distribution) / Efficiency

**Note 2:** The LED life-time define as the estimated time to 50% degradation of initial luminous.

### Backlight input signal characteristics

Symbol	Parameter	Min	Typ	Max	Units	Remark
VLED (Note 1)	LED Power Supply	6.5	12.0	21.0	[Volt]	Define as Connector Interface (Ta=25°C)
VLED_EN	LED Enable Input High Level	2.5	--	5.5	[Volt]	
	LED Enable Input Low Level	--	--	0.7	[Volt]	
VPWM_EN	PWM Logic Input High Level	2.5	--	5.5	[Volt]	
	PWM Logic Input Low Level	--	--	0.7	[Volt]	
FPWM	PWM Input Frequency *1	200	1K	20K	Hz	
Duty	PWM Duty Ratio	5	--	100	%	

**Note1:** Measured on panel VLED

## 6. Signal Characteristic

### 6.1 Pixel Format Image

Following figure shows the relationship between input signal and LCD pixel format.

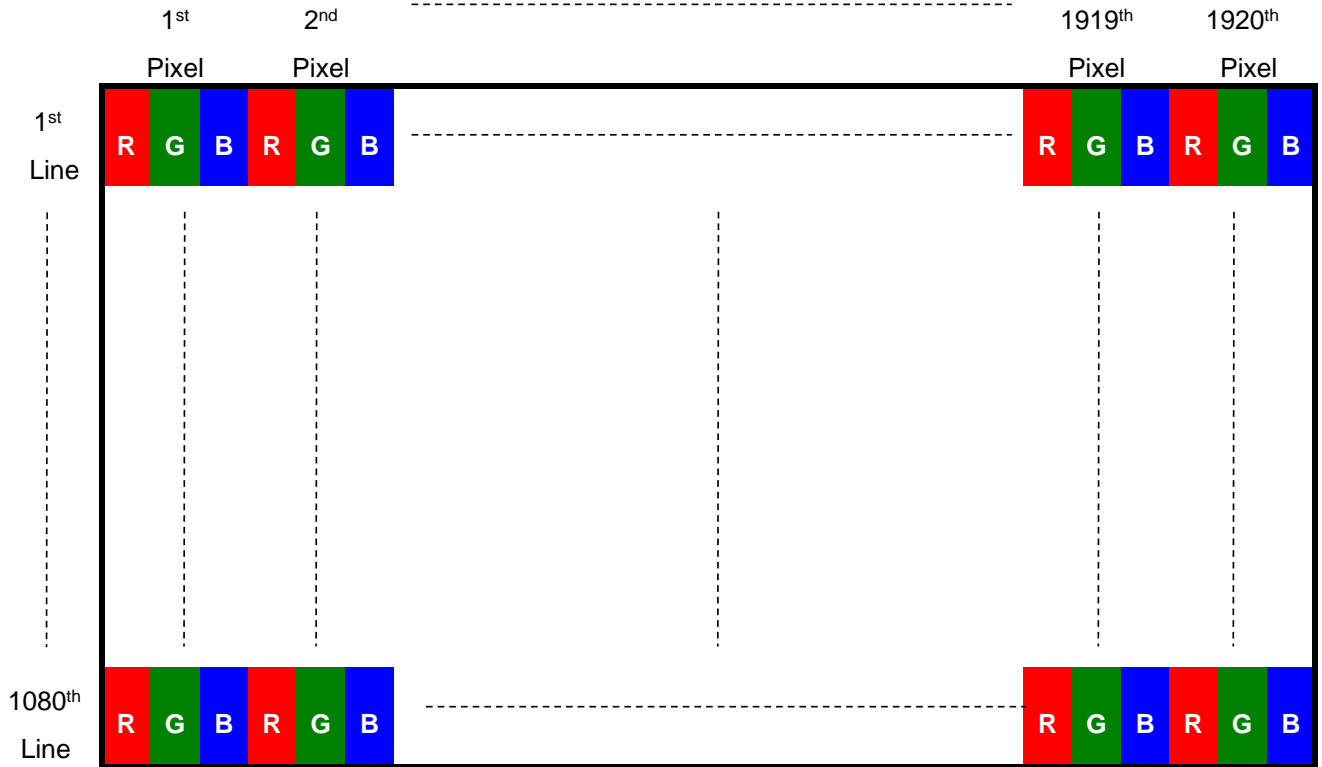

## 6.2 Integration Interface Requirement

### 6.2.1 Connector Description

Physical interface is described as for the connector on module.

These connectors are capable of accommodating the following signals and will be following components.

Connector Name / Designation	For Signal Connector
Manufacturer	IPEX or compatible
Type / Part Number	IPEX 20455-030E-12
Mating Housing/Part Number	IPEX 20453-030T-11 or compatible

### 6.2.2 Pin Assignment

eDP lane is a differential signal technology for LCD interface and high speed data transfer device.

Pin No,	Signal	Description
1	NC	NO Connect
2	H_GND	High Speed Ground
3	Lane1_N	Comp Signal Link Lane 1
4	Lane1_P	True Signal Link Lane 1
5	H_GND	High Speed Ground
6	Lane0_N	Comp Signal Link Lane 0
7	Lane0_P	True Signal Link Lane 0
8	H_GND	High Speed Ground
9	AUX_CH_P	True Signal Auxiliary Ch.
10	AUX_CH_N	Comp Signal Auxiliary Ch.
11	H_GND	High Speed Ground
12	LCD_VCC	LCD logic and driver power
13	LCD_VCC	LCD logic and driver power
14	LCD_Self_Test	LCD Panel Self Test Enable
15	LCD_GND	LCD logic and driver ground
16	LCD_GND	LCD logic and driver ground
17	HPD	HPD signal pin
18	BL_GND	Backlight ground
19	BL_GND	Backlight ground
20	BL_GND	Backlight ground
21	BL_GND	Backlight ground
22	BL_Enable	Backlight On / Off
23	BL_PWM_DIM	System PWM signal Input
24	NC	No connect



25	NC	No connect
26	BL_PWR	Backlight power
27	BL_PWR	Backlight power
28	BL_PWR	Backlight power
29	BL_PWR	Backlight power
30	NC	No connect

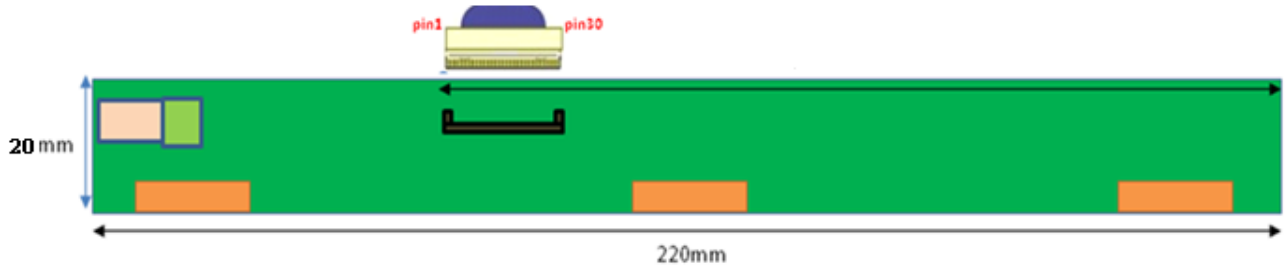

Note1: Start from right side.

Note2: Input signals shall be low or High-impedance state when VDD is off.  
Internal circuit of **eDP inputs** are as following.

## 6.3 Interface Timing

### 6.3.1 Timing Characteristics

Basically, interface timings should match the 1920x1080 /60Hz manufacturing guide line timing.

Parameter		Symbol	Min.	Typ.	Max.	Unit
Frame Rate		-		60	-	Hz
Clock frequency		1/ T <sub>Clock</sub>		141		MHz
Vertical Section	Period	T <sub>V</sub>		1116	1080+A	T <sub>Line</sub>
	Active	T <sub>VD</sub>	1080			
	Blanking	T <sub>VB</sub>		36	A	
Horizontal Section	Period	T <sub>H</sub>		2104	1920+B	T <sub>Clock</sub>
	Active	T <sub>HD</sub>	1920			
	Blanking	T <sub>HB</sub>		184		

**Note 1** : The above is as temporary setting

**Note 2** : The maximum clock frequency =  $(1920+B) \cdot (1080+A) \cdot 60 < 149.1$  MHz

## 6.4 Power ON / OFF Sequence

Power on/off sequence is as follows. Interface signals and LED on/off sequence are also shown in the chart. Signals from any system shall be Hi-Z state or low level when VDD is off

### Display Port Panel Power Sequence

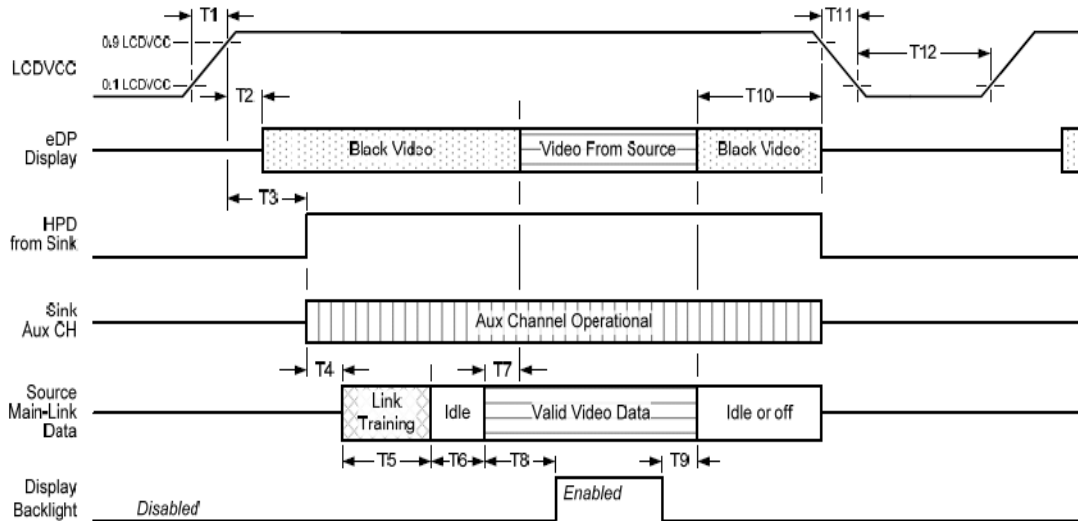

Display port interface power up/down sequence, normal system operation

### Display Port AUX\_CH Transaction Only

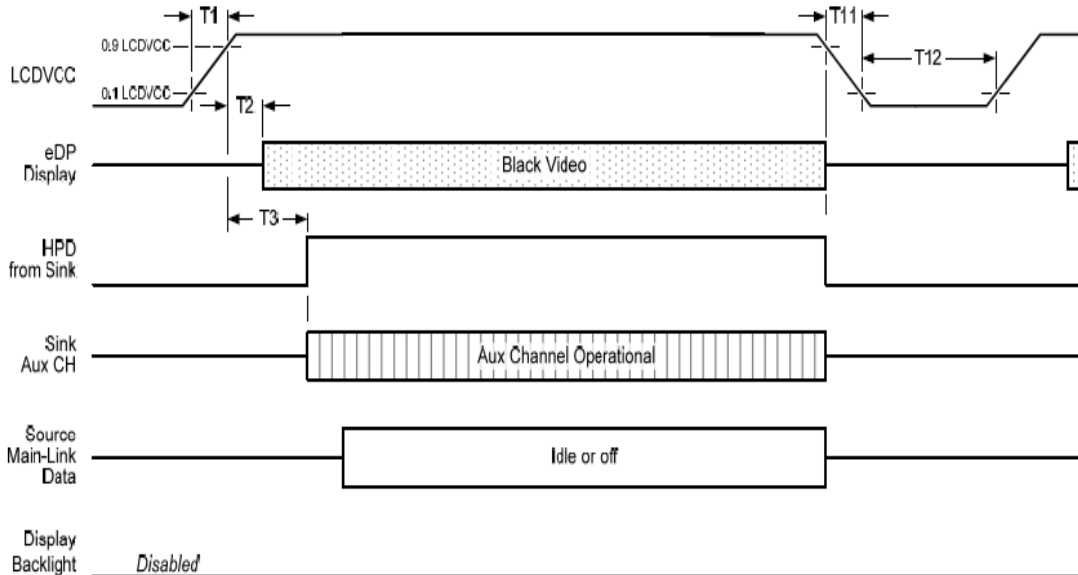

Display port interface power up/down sequence, AUX\_CH transaction only



## Display Port Panel Power Sequence Timing Parameter

Timing parameter	Description	Reqd. by	Limits			Notes
			Min.	Typ.	Max.	
T1	power rail rise time, 10% to 90%	source	0.5ms		10ms	
T2	delay from LCDVDD to black video generation	sink	0ms		200ms	prevents display noise until valid video data is received from the source
T3	delay from LCDVDD to HPD high	sink	0ms		200ms	sink AUX_CH must be operational upon HPD high.
T4	delay from HPD high to link training initialization	source				allows for source to read link capability and initialize.
T5	link training duration	source				dependant on source link to read training protocol.
T6	link idle	source				Min accounts for required BS-Idle pattern. Max allows for source frame synchronization.
T7	delay from valid video data from source to video on display	sink	0ms		50ms	max allows sink validate video data and timing.
T8	delay from valid video data from source to backlight enable	source				source must assure display video is stable.
T9	delay from backlight disable to end of valid video data	source				source must assure backlight is no longer illuminated.
T10	delay from end of valid video data from source to power off	source	0ms		500ms	
T11	power rail fall time, 90% to 10%	source			10ms	
T12	power off time	source	500ms			

**Note1:** The sink must include the ability to generate black video autonomously. The sink must automatically enable black video under the following conditions:

- upon LCDVDD power on (with in T2 max)-when the "Novideostream\_Flag" (VB-ID Bit 3) is received from the source (at the end of T9).

- when no main link data, or invalid video data, is received from the source. Black video must be displayed within 64ms (typ) from the start of either condition. Video data can be deemed invalid based on MSA and timing information, for example.

**Note 2:** The sink may implement the ability to disable the black video function, as described in Note 1, above, for system development and debugging purpose.

**Note 3:** The sink must support AUX\_CH polling by the source immediately following LCDVDD power on without causing damage to the sink device (the source can re-try if the sink is not ready). The sink must be able to respond to an AUX\_CH transaction with the time specified within T3 max.

## Display Port Panel B/L Power Sequence Timing Parameter

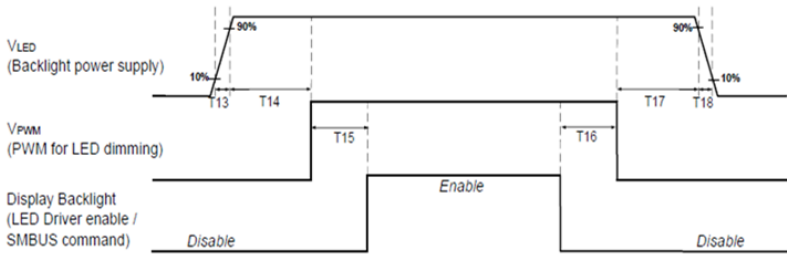

Note : When the adapter is hot plugged, the backlight power supply sequence is shown as below.

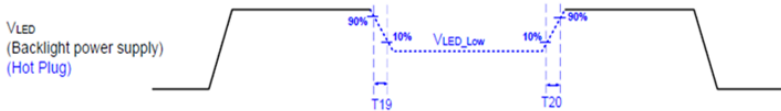

	Min (ms)	Max (ms)
T13	0.5	10
T14	10	-
T15	10	-
T16	10	-
T17	10	-
T18	0.5	10
T19	1 <sup>*</sup>	-
T20	1 <sup>*</sup>	-

Seamless change: T19/T20 = 5xT<sub>PWM</sub><sup>\*</sup>

<sup>\*</sup>T<sub>PWM</sub> = 1/PWM Frequency

## 7. Reliability Test Criteria

Items	Required Condition	Note
Temperature Humidity Bias	40 °C /90%,300Hr	
High Temperature Operation	50 °C, 300Hr (center point of panel surface)	
Low Temperature Operation	0 °C, 300Hr	
Hot Storage	60 °C, 300 hours	
Cold Storage	-20 °C, 300 hours	
Thermal Shock Test	-20 °C /30 min ,60 °C /30 min ,100cycles, 40 °C minimum ramp rate	
Hot Start Test	70 °C /1 Hr min. power on/off per 5 minutes, 5 times	
Cold Start Test	-20 °C /1 Hr min. power on/off per 5 minutes, 5 times	
Shock Test (Non-Operating)	50G,20ms,Half-sine wave,(+X,+Y,+Z)	
Vibration Test (Non-Operating)	1.5G, 10~200~10Hz, Sine wave 30mins/axis, 3 direction (X, Y, Z)	
On/off test	On/10 sec, Off/10 sec, 30,000 cycles	
ESD	Contact : ± 8KV/ operation, Class B Air : ± 15KV / operation, Class B	Note 1
EMI	30-230 MHz, limit 40 dBu V/m, 230-1000 MHz, limit 47 dBu V/m	

Note1: According to EN61000-4-2 , ESD class B: Some performance degradation allowed. No data lost . Self-recoverable. No hardware failures.

Note2:



# Product Specification

---

AU OPTRONICS CORPORATION

- Water condensation is not allowed for each test items.
- Each test is done by new TFT-LCD module. Don't use the same TFT-LCD module repeatedly for reliability test.
- To inspect TFT-LCD module after reliability test, please store it at room temperature and room humidity for 24 hours at least in advance.



# Product Specification

AU OPTRONICS CORPORATION

## 8. Mechanical Characteristics

### 8.1 LCM Outline Dimension

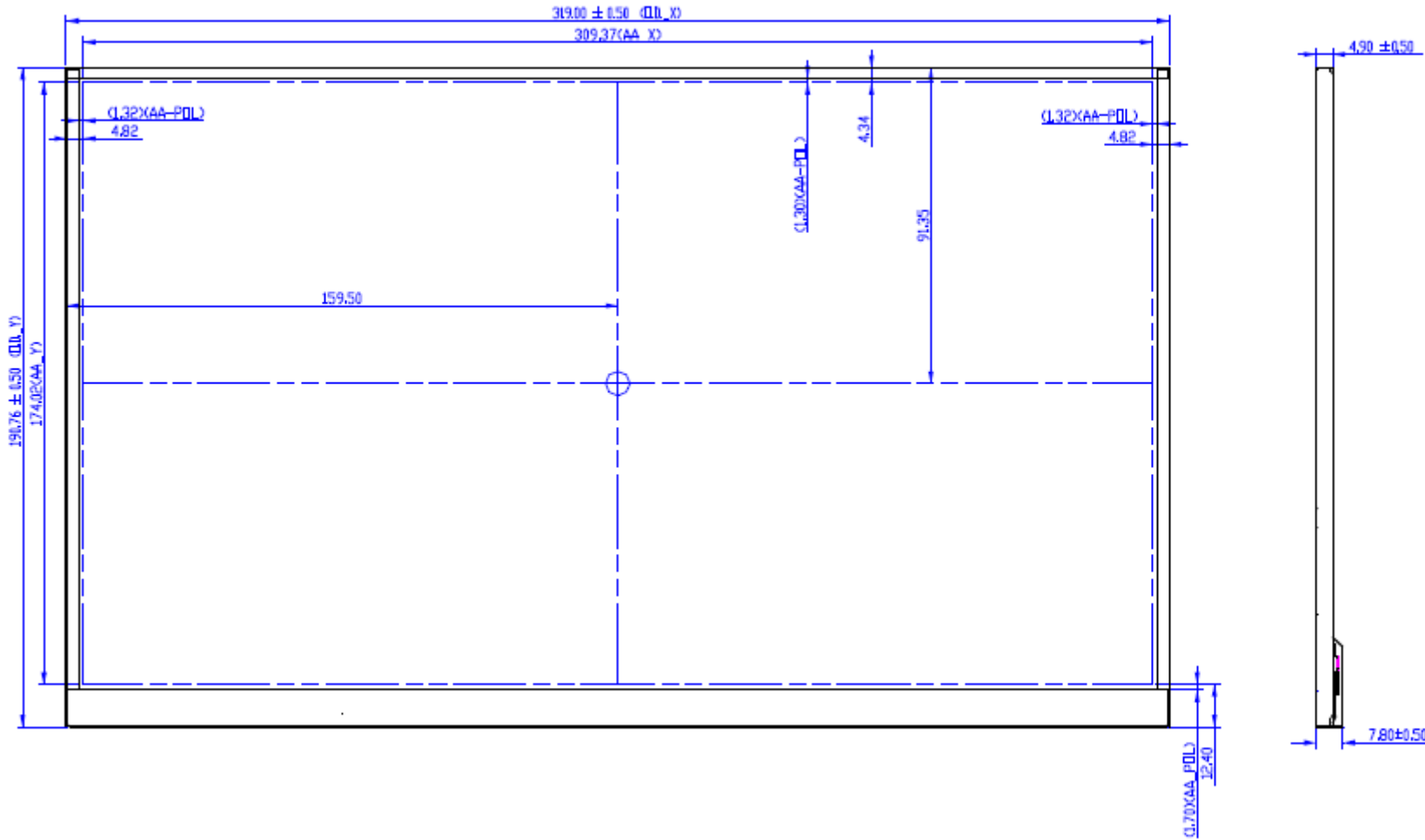



# Product Specification

AU OPTRONICS CORPORATION

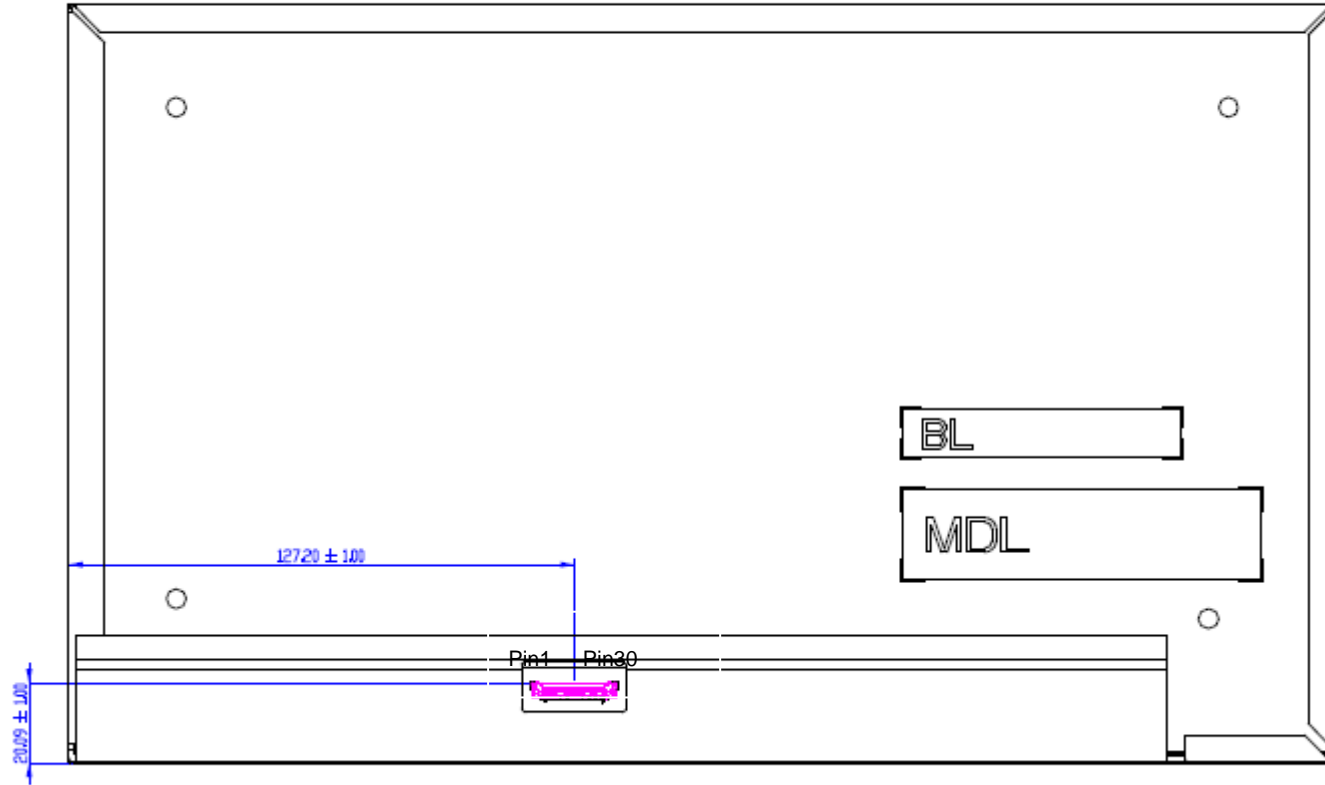



## 9. Label and Packaging

### 9.1 Shipping Label (on the rear side of TFT-LCD display)

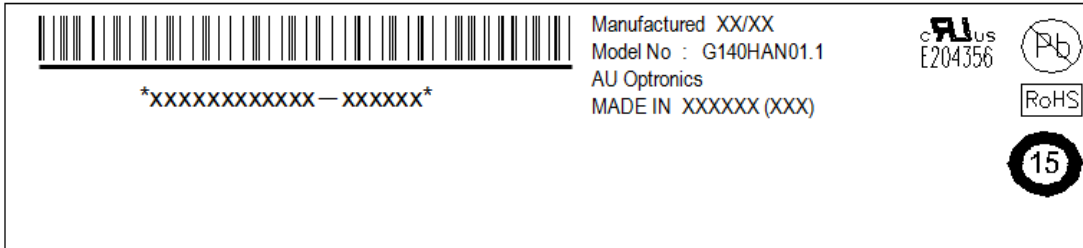

### 9.2 Carton Package

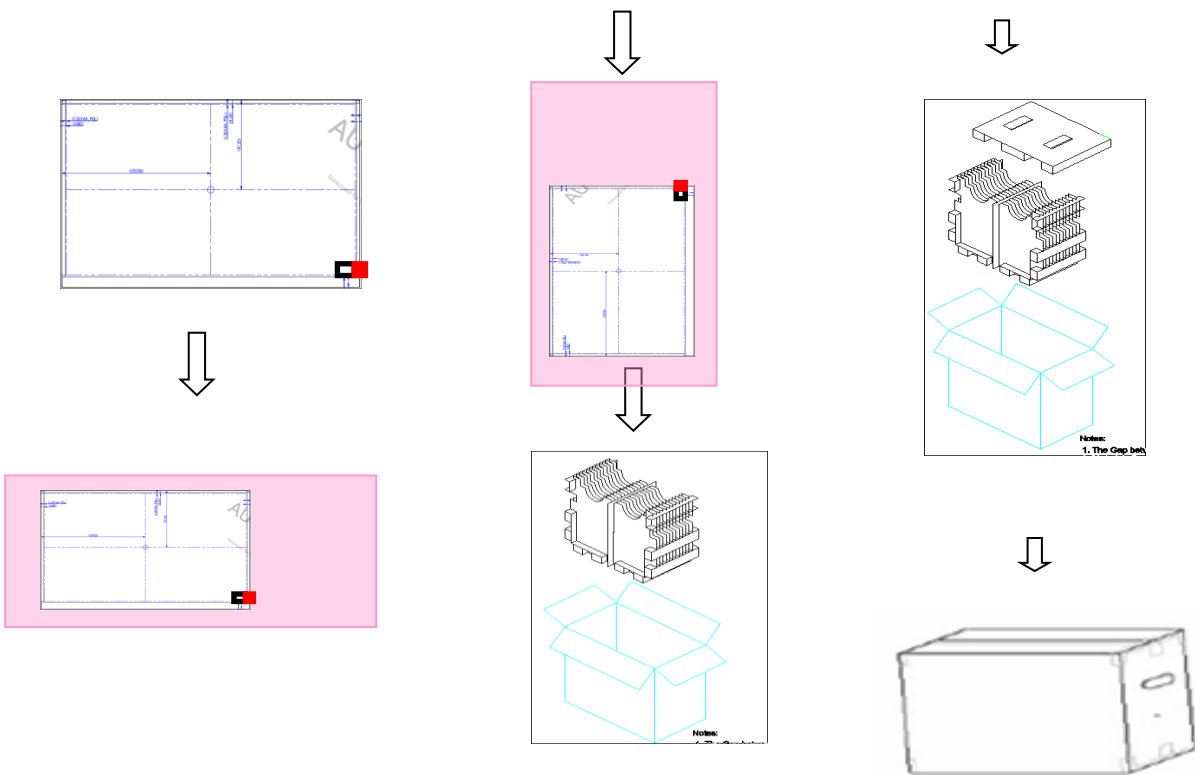

Max capacity : 22 pcs TFT-LCD module per carton

Max weight: 14.56 kg per carton

Outside dimension of carton: 484(L) mm x 279(W) mm x 432(H) mm

Pallet size : 1150 \* 910 \* 132mm

Module by air : (2 \*3) \*3 layers , one pallet put 18 boxes , total 396pcs module

Module by sea : One pallet (2 \*3) \*3 layers + One pallet (2 \*3) \*1 layers , total 528pcs module

Module by sea\_ HQ : One pallet (2 \*3) \*3 layers + One pallet (2 \*3) \*2ayers Total 660pcs module